

PROJECT SPECIFICATIONS for EAST 86TH AND MADISON COURT PRV STATION REPLACEMENT

FINAL DESIGN SUBMITTAL

ISSUED FOR BID



Prepared For:
City of Thornton
9500 Civic Center Drive, 2nd Floor
Thornton, CO 80229



Prepared By:
Olsson
1525 N Raleigh Street, Suite 400
Denver, CO 80204

Project Name: 2025 Treated Water System Improvements
Project #: 025-02626

SECTION 00 0110

TABLE OF CONTENTS

SECTIONS

DIVISION 01 — GENERAL REQUIREMENTS

01 1000 - SUMMARY

01 2200 - UNIT PRICES

DIVISION 02 — EXISTING CONDITIONS

02 4119 - SELECTIVE DEMOLITION

DIVISION 26 — ELECTRICAL

26 0100 - BASIC ELECTRICAL REQUIREMENTS

26 0150 - BASIC ELECTRICAL MATERIALS AND METHODS

26 0519 - LOW-VOLTAGE ELECTRICAL POWER CONDUCTORS AND CABLES

26 0526 - GROUNDING AND BONDING FOR ELECTRICAL SYSTEMS

26 0533 - RACEWAYS AND BOXES FOR ELECTRICAL SYSTEMS

26 0553 - IDENTIFICATION FOR ELECTRICAL SYSTEMS

DIVISION 31 — EARTHWORK

31 2300 - EXCAVATION AND FILL

31 2319 - DEWATERING

31 2323.33 - FLOWABLE FILL

31 2333 - TRENCHING AND BACKFILLING

31 2500 - EROSION AND SEDIMENTATION CONTROLS

DIVISION 32 — EXTERIOR IMPROVEMENTS

32 1216 - ASPHALT PAVING

32 9200 - SEEDING

DIVISION 33 — UTILITIES

33 0500 - COMMON WORK RESULTS FOR UTILITIES

33 1415 - SITE WATER DISTRIBUTION PIPING

APPENDIX A – GEOTECHNICAL REPORT

APPENDIX B – SUE REPORT

SECTION 01 1000 - SUMMARY

PART 1 - GENERAL

1.1 SUMMARY

- A. Section Includes:
 - 1. Project information.
 - 2. Contract description.
 - 3. Contractor's use of Site.
 - 4. Work restrictions.

1.2 PROJECT INFORMATION

- A. Name: 2025 Treated Water System Improvements, East 86th and Madison Court PRV Station Replacement.
 - 1. Project Location: East 86th Ave. and Madison Court.
- B. Owner Municipality: City of Thornton.
 - 1. Owner's Representative: Mark Mazzucco, 12450 Washington Street, Thornton, CO 80241-2405.
- C. Project Engineer: Olsson.
 - 1. Engineer's Representative: Allie Beikmann P.E.

1.3 CONTRACT DESCRIPTION

- A. Work of the Project includes furnishment and installation of an underground 8-inch pressure reducing valve station, removal and haul away of the existing 8" PRV station, electrical service, connection to the existing 8-inch waterline, removal and replacement of a wood privacy fence, asphalt patching, erosion control, tree removal, traffic control, and revegetation.

1.4 CONTRACTOR'S USE OF SITE

- A. Limits on Use of Site: Limit use of Project Site for construction operations as indicated on Drawings by the Limits of Construction. Upon removal of the trees and fence according to Section 02 4119 "Selective Demolition," the site shall be accessed through the Madison Court cul-de-sac. Do not disturb portions of Project Site beyond areas in which the Work is indicated.
- B. Utility Outages and Shutdown:
 - 1. Coordinate and schedule electrical and other utility outages with Owner.
 - 2. Outages: Allow only at previously agreed upon times. Schedule outages at times when facility is not being used.
 - 3. At least one week before scheduled outage, submit outage request plan to Engineer Owner itemizing dates, times, and duration of each requested outage.
- C. Sound Level Restrictions: Sound pressure level measured at boundary of Site shall not exceed 40 dBA.

- D. Construction Plan: Before start of construction, submit copy of proposed construction plan regarding access to Work, use of Site, and utility outages for acceptance by Owner. After acceptance of plan, construction operations shall comply with accepted plan unless deviations are accepted by Owner in writing.
- E. The Contractor shall maintain the most current, Owner-accepted construction drawings, specifications, addenda, and approved revisions on site at all times for reference by field personnel.

1.5 WORK RESTRICTIONS

- A. Comply with restrictions on construction operations.
 - 1. Comply with limitations on use of public streets, work on public streets, rights of way, and other requirements of authorities having jurisdiction (AHJ).
- B. On-Site Work Hours: Limit Work to between 7:00 a.m. to 4:00 p.m., Monday through Friday, unless otherwise indicated. Work hours may be modified to meet Project requirements if approved by Owner and AHJ.
- C. Existing Utility Interruptions: Do not interrupt utilities serving facilities occupied by Owner or others unless permitted under the following conditions, and only after arranging for temporary utility services according to requirements indicated:
 - 1. Notify Municipality not less than two days in advance of proposed utility interruptions.
 - 2. Obtain Municipality's written permission before proceeding with utility interruptions.
- D. Noise, Vibration, Dust, and Odors: Coordinate with Owner operations that may result in high levels of noise and vibration, dust, odors, or other disruption to Owner occupancy.
 - 1. Notify Municipality not less than two days in advance of proposed disruptive operations.
 - 2. Obtain Municipality's written permission before proceeding with disruptive operations.

1.6 PERMITS

- A. Furnish all necessary permits for construction of Work including, but not limited to, the following:
 - 1. General construction permit
 - 2. Sewer/water service repair permit
 - 3. Building permit
 - 4. Stormwater permit
 - 5. Traffic control permit
 - 6. Dewatering permit
 - 7. Sandblasting permit

PART 2 - PRODUCTS - Not Used

PART 3 - EXECUTION - Not Used

END OF SECTION 01 1000

SECTION 01 2200 - UNIT PRICES

PART 1 - GENERAL

1.1 SUMMARY

- A. Section includes administrative and procedural requirements for Work performed under a unit price contract.

1.2 DEFINITIONS

- A. Unit price is an amount incorporated into the Agreement, applicable during the duration of the Work as a price per unit of measurement for materials, equipment, or services, or a portion of the Work, added to or deducted from the Contract Sum by appropriate modification, if the scope of Work or estimated quantities of Work required by the Contract Documents are increased or decreased.

1.3 PROCEDURES

- A. Unit prices include all necessary material, plus cost for delivery, installation, insurance, applicable taxes, overhead, and profit.
- B. Measurement and Payment: Methods of measurement and payment for unit prices are specified in "Execution" of this Section.
- C. Owner reserves the right to reject Contractor's measurement of work-in-place that involves use of established unit prices and to have this work measured, at Owner's expense, by an independent surveyor acceptable to Contractor.
- D. List of Unit Prices: A schedule of unit prices is included in Part 3. Specification Sections referenced in the Part 3.1 "Schedule of Unit Prices" Article contain requirements for materials described under each unit price.

1.4 MEASUREMENT

- A. Measurement by weight: Items measured by weight will use specified standard handbook weights unless otherwise specified in this section for an individual item.
- B. Measurement by volume: Unless herein noted differently, volume shall be measured by cubic dimension using mean length, width and height or thickness with survey chain, steel tape, approved distance meter, or by use of Total Surveying Stations and Engineering Software, as approved by Engineer.
- C. Measurement by area: Unless herein noted differently, area shall be measured by square dimension using mean length and width or radius, with survey chain, steel tape, approved distance meter, or by use of Total Surveying Stations and Engineering Software, as approved by Engineer.
- D. Linear measurement: Unless herein noted differently, linear measurements shall be measured at the item centerline or mean chord, with survey chain, steel tape, approved distance meter, or by use of Total Surveying Stations and Engineering Software, as approved by Engineer.
- E. Stipulated price measurement: Items measure by weight, volume, area, or linear means or combination, as appropriate, as a completed item or unit of the Work.

1.5 PAYMENT

- A. Unit bid prices, as quotes in the Unit Price Schedule, shall constitute full compensation for labor, materials, equipment, rentals, overhead, profit, and incidentals to complete all work for each pay item and for all risk, loss, damage, or expense of whatever nature arising from the nature of the work or execution thereof.
- B. Work or materials that are essential to the work, but for which there are no pay items, will not be measure and paid for separately, but shall be included in other items of work.
- C. Payment for the work listed as lump sum bid items completed under this contract shall be paid for as a single, lump sum price.

1.6 NON-PAYMENT FOR REJECTED PRODUCTS

- A. Payment will not be made for any of the following:
 - 1. Products wasted or disposed of in a manner that is not acceptable.
 - 2. Products determined as unacceptable before or after placement.
 - 3. Products not completely unloaded from the transporting vehicle.
 - 4. Products placed beyond the lines, levels, or boundaries of the required Work.
 - 5. Products remaining on hand after completion of the Work
 - 6. Loading, hauling, and disposing of rejected Products.
 - 7. Work performed beyond the specified limit unless authorized by the Engineer.

PART 2 - PRODUCTS (Not Used)

PART 3 - EXECUTION

SCHEDULE 1 - SCHEDULE OF UNIT PRICES

3.1 SITE MOBILIZATION / DEMOBILIZATION

- A. All preparatory work operations, including but not limited to those necessary for the movement of personnel, equipment, supplies, and incidentals to the project site; and for all other work and operations which must be performed or costs incurred before beginning work at the project site.
- B. Unit price shall also include bonds and insurance, and any incidental work and equipment necessary for mobilization, required permits, and materials testing. The demobilization and removal of the Contractor's equipment, supplies, and excess materials are also included in the mobilization bid item.
- C. Mobilization will be restricted to a max price bid of 7-percent of the total bid with an equitable amount to be withheld until demobilization after final completion.
- D. Mobilization shall be a lump sum bid item.

<u>Bid Item</u>	<u>Pay Unit</u>
Site mobilization / Demobilization	LS

3.2 Construction Surveying

- A. All materials, labor, and equipment necessary to provide all construction surveying, grade staking, and all record drawing survey.
- B. The lump sum bid item will include all of Contractor's costs and no measurement for payment shall be made of any of the work, materials, and equipment required for this item. Payment will be based on the percentage of completed and accepted Work.

<u>Bid Item</u>	<u>Pay Unit</u>
Construction Surveying	LS

3.3 Traffic Control

- A. Unit price includes preparing, implementing, adjusting as necessary, and maintaining the approved Traffic Control Plan in accordance with the Drawings and Specifications; and providing all other related and necessary labor, equipment, and materials to complete the Work.
- B. The lump sum bid item will include all of Contractor's costs for any labor, equipment, and materials required for this item. Payment will be based on the percentage of completed and accepted Work. One-third of the lump sum price for this item will be paid after twenty-five percent (25%) of the original contract amount has been earned; the second third will be paid after fifty percent (50%) of the original contract amount has been earned; and the final third upon final acceptance of the project.

<u>Bid Item</u>	<u>Pay Unit</u>
Traffic Control	LS

3.4 Erosion Control

- A. Unit price includes, but is not limited to, furnishing and installing all structural and non-structural best management practices (BMPs) as shown on the Drawings and as required by the City of Thornton, including silt fence, vehicle tracking pads, concrete wash out areas, and other required control measures such as inlet protection. The Contractor shall be responsible for the implementation, inspection, maintenance, and removal of all BMPs in accordance with the project specifications.
- B. The lump sum price bid shall be full compensation for all labor, materials, equipment, and incidentals necessary to complete the Work.

<u>Bid Item</u>	<u>Pay Unit</u>
Erosion Control	LS

3.5 Safety Bollards

- A. Unit price Includes furnishing and installing the safety bollards as shown on the Drawings and providing all other related and necessary labor, equipment, and materials to complete the Work.
- B. Payment will be based on units installed and accepted.

<u>Bid Item</u>	<u>Pay Unit</u>
Safety Bollards	EA

3.6 Site Demolition

- A. Site Demolition includes all labor, materials, equipment, and incidentals necessary to remove the following: existing PRV vault and all interior and exterior materials and

equipment, existing wood privacy fence, asphalt paving, one (1) tree, and buried 8" PVC piping. Demolition also includes abandonment of buried 8" PVC with flowable fill per the Contract Documents. Work shall include removal, haul, and disposal.

- B. The lump sum bid item will include all of Contractor's costs and no measurement for payment shall be made of any of the work, materials, and equipment required for this item. Payment will be based on the percentage of completed and accepted Work.

<u>Bid Item</u>	<u>Pay Unit</u>
Remove and Replace 6' Wood Fence	EA

3.7 8" AWWA C900 PVC

- A. Unit price shall include pipe, locating and protecting existing utilities, excavation, bedding material, fittings, restraint, thrust blocks, backfill, compaction, tracer wire, warning tape, testing, and all incidentals required to install the pipe.
- B. The measurement of the lineal feet of new water line shall be measured horizontally from the centerline of the fitting to centerline of fitting. The quantity to be measured for payment shall be the number of lineal feet of pipe complete in place.

<u>Bid Item</u>	<u>Pay Unit</u>
8" AWWA C900 PVC	LF

3.8 8" M.J. Gate Valve with Valve Box

- A. Unit price shall include gate valve, valve box, locating and protecting existing utilities, excavation, bedding material, fittings, restraint, thrust blocks, backfill, compaction, tracer wire, warning tape, testing, and all incidentals required to install the valve.
- B. Payment will be based on units installed and accepted.

<u>Bid Item</u>	<u>Pay Unit</u>
-----------------	-----------------

3.9 8" M.J. Gate Valve with Valve Box EA

3.10 8" 45 Degree M.J. fittings with Thrust Block

- A. Unit price shall include 45 degree bend fitting, locating and protecting existing utilities, excavation, bedding material, fittings, restraint, thrust blocks, backfill, compaction, tracer wire, warning tape, testing, and all incidentals required to install the bend.
- B. Payment will be based on units installed and accepted.

<u>Bid Item</u>	<u>Pay Unit</u>
8" 45 Degree M.J. fittings with Thrust Block	EA

3.11 8" PRV Package Vault

- 1. The lump sum price bid for the 8" PRV Package Vault shall include all costs incurred for furnishing and installing An underground pre-manufactured pressure reducing vault in accordance with the Drawings and Specifications. This bid item includes all labor, materials, equipment, and incidentals required to cut and modify the existing line; install new process piping through the vault; and furnish and install all associated components. This includes all vault structure elements such as aggregate base, structural concrete, access hatch, ladder. The price also includes coordination with utility providers, trenching, dewatering, backfill, compaction, testing, and surface restoration in accordance with the project specifications and applicable codes.

2. Payment shall include full compensation for assembling and placing all materials required to install the unit, complete in place.

<u>Bid Item</u>	<u>Pay Unit</u>
8" PRV Package Vault	LS

3.12 Connect to Existing 8" Water Main

1. The quantity to be measured for payment shall be the number of water main connections made to the existing 8-inch waterline after testing of the main is completed. This item will also include all fittings, thrust collars, thrust blocks, and all incidental work associated with the connection and as shown in the Drawings for a complete installation.
2. Payment will be based on connections completed and accepted.

<u>Bid Item</u>	<u>Pay Unit</u>
Connect to Existing 8" Water Main	EA

3.13 Site Restoration and Revegetation

1. Unit price shall include all costs incurred for furnishing and installing new fence materials to match existing type and height, replacing removed asphalt pavement in kind, replanting a tree with stakeholder coordination, site revegetation, and general site cleanup. Work shall include careful removal of existing fence components, site preparation, restoration of disturbed areas, and shall conform to applicable local standards.
2. The lump sum bid item will include all of Contractor's costs and no measurement for payment shall be made of any of the work, materials, and equipment required for this item. Payment will be based on the percentage of completed and accepted Work.

<u>Bid Item</u>	<u>Pay Unit</u>
Site Restoration and Revegetation	LS

3.14 1.5" PVC Sch 40 Conduit

3.15 2" PVC Sch 80 Conduit

3.16 #2 AWG XHHW Conductor

3.17 #4 AWG XHHW Conductor

3.18 #6 AWG XHHW Conductor

3.19 Ground Rods

3.20 Electric Service, Meter Pedestal and Main Breaker

1. Unit of Measurement: The quantity to be measured for payment shall be the number of lineal feet of conduit and conductor, complete in place with ground rods and electric service, meter pedestal and main break made by the each installed complete in place and accepted.
2. Assigned Unit Cost: The payment sum price bid shall include all costs incurred for furnishing and installing electrical systems to support existing and new valve vaults. This includes all labor, materials, equipment, and incidentals required to provide lighting and power circuits, including conduit and wiring to serve exhaust

fans, sump pumps, dehumidifiers, flow meters, valve actuators, and heat trace systems. The work also includes coordination with other trades, testing, labeling, and compliance with applicable codes and project specifications to deliver a complete and operational electrical installation.

<u>Bid Item</u>	<u>Pay Unit</u>
1.5" PVC Sch 40 Conduit	LF
2" PVC Sch 80 Conduit	LF
#2 AWG XHHW Conductor	LF
#4 AWG XHHW Conductor	LF
#6 AWG XHHW Conductor	LF
Ground Rods	EA
Electric Service, Meter Pedestal and Main Breaker	EA

END OF SECTION 01 2200

SECTION 02 4119 - SELECTIVE DEMOLITION

PART 1 - GENERAL

1.1 SUMMARY

A. The Work of this Section Includes:

1. Demolition and removal of buried structure and selected site elements.

B. Related Requirements:

1. Section 01 1000 "Summary" for restrictions on use of the premises.

1.2 DEFINITIONS

- A. Remove: Detach items from existing construction and legally dispose of off-site unless indicated to be removed and salvaged or removed and reinstalled.

- B. Existing to Remain: Existing items of construction that are not to be removed.

1.3 MATERIALS OWNERSHIP

- A. Unless otherwise indicated, demolition waste becomes property of Contractor. Owner assumes no responsibility for materials and structures to be demolished. Owner does not intend to salvage materials demolished.

- B. Historic items, relics, antiques, and similar objects including, but not limited to, cornerstones and their contents, commemorative plaques and tablets, and other items of interest or value to Owner that may be uncovered during demolition remain the property of Owner.

1. Carefully salvage in a manner to prevent damage and promptly return to Owner.

- C. Structures to be demolished shall be vacated and their use discontinued before start of the demolition.

- D. On-site storage or sale of removed items or materials is not permitted.

1.4 INFORMATIONAL SUBMITTALS

- A. Proposed Protection Measures: Submit report, including Drawings, that indicates the measures proposed for protecting individuals and property, and for dust control. Indicate proposed locations and construction of barriers.

- B. Schedule of Selective Demolition Activities: Indicate the following:

1. Sequence of selective demolition and removal work, with start and end dates for each activity. Ensure Owner's on-site operations are uninterrupted.
2. Temporary interruption of utility services. Indicate how long utility services will be interrupted.
3. Coordination for shutoff, capping, and continuation of utility services.

1.5 CLOSEOUT SUBMITTALS

- A. Inventory: Submit a list of items that have been removed and salvaged.

1.6 FIELD CONDITIONS

- A. Conditions existing at time of inspection for bidding purpose will be maintained by Owner as far as practical.
- B. Notify Engineer of discrepancies between existing conditions and Drawings before proceeding with selective demolition.
- C. Hazardous Materials:
 - 1. It is not expected that hazardous materials will be encountered in the Work.
 - a. If materials suspected of containing hazardous materials are encountered, do not disturb; immediately notify Engineer and Owner. Hazardous materials will be removed by Owner under a separate contract.

1.7 WARRANTY

- A. Existing Warranties: Remove, replace, patch, and repair materials and surfaces cut or damaged during selective demolition, by methods and with materials and using approved contractors so as not to void existing warranties.
- B. Notify warrantor on completion of selective demolition, and obtain documentation verifying that existing system has been inspected and warranty remains in effect. Submit documentation at Project closeout.

PART 2 - PRODUCTS

2.1 PERFORMANCE REQUIREMENTS

- A. Regulatory Requirements: Comply with hauling and disposal regulations of authorities having jurisdiction.

PART 3 - EXECUTION

3.1 EXAMINATION

- A. Verify that utilities have been disconnected and capped before starting selective demolition operations.
- B. Survey of Existing Conditions: Record existing conditions by use of preconstruction photographs or video, measured drawings.

3.2 PREPARATION

- A. Temporary Shoring: Provide and maintain shoring, bracing, and structural supports as required to preserve stability and prevent movement, settlement, or collapse of earth to remain, and to prevent unexpected or uncontrolled movement or collapse of construction being demolished.
 - 1. Strengthen or add new supports when required during progress of selective demolition.
- B. Temporary Protection: Provide temporary barricades and other protection required to prevent injury to people. Provide protection to ensure safe passage of people around selective demolition area.

3.3 UTILITY SERVICES AND BUILDING SYSTEMS

- A. Existing Services/Systems to Remain: Maintain utilities to remain and protect against damage during selective demolition operations.
- B. Existing Services/Systems to Be Removed, Relocated, or Abandoned: Locate, identify, disconnect, and seal or cap off utilities serving areas to be selectively demolished.
 - 1. Arrange to shut off utilities with utility companies.
 - 2. Abandon existing piping indicated on Drawings to be abandoned in place, per the Drawing notes.

3.4 SELECTIVE DEMOLITION, GENERAL

- A. Site Access and Temporary Controls: Conduct selective demolition and debris-removal operations to ensure minimum interference with roads, streets, walks, walkways, and other adjacent occupied and used facilities.
 - 1. Do not close or obstruct streets, walks, walkways, or other adjacent occupied or used facilities without permission from Owner and authorities having jurisdiction. Provide alternate routes around closed or obstructed trafficways if required by authorities having jurisdiction.
 - 2. Use water mist and other suitable methods to limit spread of dust and dirt. Comply with governing environmental-protection regulations. Do not use water when it may damage adjacent construction or create hazardous or objectionable conditions, such as ice, flooding, and pollution.

3.5 SELECTIVE DEMOLITION PROCEDURES FOR SPECIFIC MATERIALS

- A. Pavement, Sidewalks, Curbs, Etc.
 - 1. Portland Cement Concrete (PCC) or asphaltic concrete that is to remain shall be cut in a straight, true line with a vertical face. PCC or asphaltic concrete may be cut with a cutting wheel, jackhammer (demolition of structure following surrounding clean cuts), or saw, or may be broken to the directed point of removal. Contractor shall be responsible for the cost of removal and replacement of overbreak as identified on the construction plans.
- B. Trees:
 - 1. This work shall be done by a Contractor or subcontractor who is a qualified tree surgeon and a member of the National Arborist Association. The firm's or individual's name and qualifications shall be submitted at the preconstruction conference for the Owner's approval.
 - 2. Access for the removal or pruning of trees will be extremely limited. Trees shall be felled at the risk of the Contractor. Limits of disturbance shall be defined and shall be adhered to.
 - 3. All brush, branches, limbs, and foliage smaller than 3 inches in diameter shall be chipped into mulch and stockpiled at a designated site. The trunks and limbs 3 inches and larger shall be cut into less than 6 foot lengths and hauled to a designated site. Stumps shall be left no higher than 2 feet above the ground surface and shall not be removed when within the areas to be excavated. When trees being cut off are outside the excavation limits, the stumps shall be cut so

that no more than 3 inches remains above the ground surface. Stump grinding is not required in any circumstances.

4. Chipping, stockpiling mulch, and hauling and stockpiling trunks and limbs will not be paid for separately but shall be included in the work. Removal of trees less than 3 inches in diameter will not be paid for separately but shall be included in the work.

3.6 DISPOSAL OF DEMOLISHED MATERIALS

- A. Except for items or materials indicated to be reused, salvaged, reinstalled, or otherwise indicated to remain on Owner's property, remove demolition waste materials from Project site and legally dispose of them.
 1. Do not allow demolished materials to accumulate on-site.
 2. Remove and transport debris in a manner that will prevent spillage on adjacent surfaces and areas.
- B. Burning: Do not burn demolished materials.

3.7 CLEANING

- A. Clean adjacent structures and improvements of dust, dirt, and debris caused by selective demolition operations. Return adjacent areas to condition existing before selective demolition operations began.

END OF SECTION 02 4119

SECTION 26 0100 - BASIC ELECTRICAL REQUIREMENTS

PART 1 - GENERAL

1.1 WORK INCLUDED

- A. The General and Supplemental General Conditions of the Contract and Division 1 of the specifications shall apply to this Division.
- B. This Section 26 0100 shall be part of each section of Division 26 - Electrical.

1.2 RELATED WORK

- A. All sections of Division 26 - Electrical.
- B. All sections of Division 1 - 48.
- C. All addenda issued.
- D. The complete installation of the electrical systems as indicated on the drawings, including details not specifically mentioned or shown that may be necessary to complete the systems.

1.3 QUALITY ASSURANCE

- A. Conform to the Uniform Building Codes.
- B. Conform to the State Building Codes.
- C. Conform to the Local Building Codes.
- D. Conform to the National Fire Protection Association.
- E. Conform to the State Fire Codes.
- F. Conform to the Local Fire Codes.
- G. Conform to the State Health Department.
- H. Conform to the Local Utility Company (gas, water, sewer, storm sewer and electric) Rules and Regulations.
- I. Conform to the National Electric Code.
- J. These codes, rules and regulations shall take precedence if the drawings and specifications are not in conformance therewith, except that where the drawings and specifications exceed minimum code requirements the drawings and specifications shall take precedence.

1.4 SUBMITTALS

- A. Refer to front portion of the specifications.
- B. Submit minimum of one (1) electronic copy or more if specified in another section, of shop drawings and product data on all electrical equipment to be provided by the Contractor.
- C. Title each drawing with project name and number; identify each element of drawings by reference to sheet number and detail, schedule or room number of Contract Documents.

- D. Sequentially number submittals according their specification section number. Revised submittals should include original number and a sequential alphabetic suffix.
- E. Contractor and supplier shall review and stamp and sign submittals prior to transmittal; determine and verify field measurements, field construction criteria, manufacturers catalog numbers and conformance of submittal with requirements of Contract Documents. Identify in writing at time of submittal of any deviations from requirements of Contract Documents.
- F. Mark dimensions and values in units to match those specified.
- G. Do not fabricate or order products or begin work that requires submittals until approval of submittal.
- H. Approval of equipment does not construe approval of equipment, components, etc., that no information is furnished to show compliance with contract documents.

1.5 SCOPE OF THE WORK

- A. The work covered by this specification shall include all labor, material, equipment and services necessary for and reasonably incidental to proper completion of all electrical work as shown on the drawings and hereinafter specified, except work or material specified to be furnished and performed by others. The work shall include but not be limited to the following:
 - 1. Electrical service.
 - 2. Electrical equipment, materials and work, connection of pumps, and miscellaneous equipment.

1.6 CHANGE ORDERS

- A. Refer to front portion of the specifications.
- B. The Contractor shall, in no instance, commence work on or provide materials for or make changes in, the work for this project which will require additional payment from the Owner to the Contractor until he has requested and obtained, in writing, either a signed written Change Order or a signed written notice to proceed with the extra work.
- C. Each request for approval of additional work that is to require additional payment from the Owner or in instances where credit is to be allowed to the Owner for omission of certain work or materials, shall be accompanied by a price quotation, including a complete cost breakdown of materials, labor, overhead and profit.

1.7 AS-BUILT DRAWINGS

- A. Refer to front portion of the specifications.
- B. This Contractor shall prepare as-built drawings for the various component portions of the electrical installations. These drawings shall be furnished to the Owner after completion of the work. These drawings shall be prepared by marking up a set of contract drawings with colored pencils to show changes made during construction after the various installations have been completed.
- C. At completion of project, Contractor shall provide equipment identification as directed in Section 26 0553.

1.8 PERMITS, LICENSES AND FEES

- A. The Contractor shall familiarize himself with all requirements as to permits, licenses, fees, codes and ordinances and arrange to comply with them. All permits, licenses, fees and inspections required for the work under this Contract shall be obtained and paid for by the Contractor unless otherwise specified.

1.9 DATA AND MEASUREMENTS

- A. The information given herein and on the drawings is as exact as could be secured, but its extreme accuracy is not guaranteed. The Electrical Contractor must examine the locations carefully and verify all measurements, distances, levels, conduit, wire sizes, obstructions, remodeling work, work of other trades, etc., before submitting bids and before starting work. The Contractor shall satisfactorily adapt his work to the actual conditions at the building.
- B. Electrical drawings are of small scale, it is not possible to show all necessary conduit, junction boxes, fittings and accessories. Furnish items as necessary for completion. Examine drawings and specifications and obtain exact locations, measurements, levels, etc. at site for placement of equipment.

1.10 COORDINATION OF WORK

- A. Refer to front portion of the specifications.
- B. The Contractor shall plan all work so that it proceeds with a minimum of interference between trades. It shall also be the responsibility of the Contractor to provide all openings required in the building construction for the installation of electrical work. Provisions shall be made for all special frames, openings and pipe sleeves as required. The Contractor shall do all extra cutting and patching made necessary by his failure to properly direct such work at the correct time.

1.11 QUALIFICATIONS OF INSTALLERS

- A. Refer to front portion of the specifications.
- B. All work shall be performed by worker skilled in the respective trade required by each part of the work. Helpers and apprentices used for any part of the work shall be under the full supervision of a thoroughly trained and skilled worker of the trade required for that part of the work. No allowance will be made for lack of skill in the acceptance or rejection of any work.

1.12 QUALITY OF WORK

- A. All work shall be of the best quality free from defects in workmanship, materials and performance.

1.13 GUARANTEE

- A. Refer to front portion of the specifications.
- B. The Contractor shall guarantee that all electrical systems shall be free from defects in workmanship, materials and performance and that if such defects shall appear during a period of one year or as specified in another section, from date of final acceptance, he will remedy such defects to the satisfaction of the Owner at no extra cost.

1.14 PROJECT/SITE CONDITIONS

- A. Install work in locations shown on drawings, unless prevented by project conditions.
- B. Prepare drawings showing proposed rearrangement of work to meet project conditions, including changes in work specified in other sections. Obtain permission of engineer before proceeding.

1.15 PACKING, TRANSPORTATION

- A. Require supplier to package finished products in boxes or crates for protection during shipment, handling and storage. Protect sensitive products against exposure to elements and moisture.
- B. Protect sensitive equipment and finishes against impact, abrasion and other damage.

1.16 DELIVERY AND RECEIVING

- A. Arrange deliveries of products in accordance with construction progress schedules. Allow time for inspection prior to installation.
- B. Coordinate deliveries to avoid conflict with work and conditions at site, work of other contractors, limitations on storage space, availability of personnel and handling equipment.
- C. Deliver products in undamaged, dry condition, in original unopened containers or packaging with identifying labels intact and legible.
- D. Clearly mark partial deliveries of component parts of equipment to identify equipment and contents to permit easy accumulation of parts and to facilitate assembly.
- E. Immediately on delivery, inspect shipment to assure:
 - 1. Products comply with requirements of contract documents and reviewed submittals.
 - 2. Quantities are correct.
 - 3. Accessories and installation hardware are correct.
 - 4. Containers and packages are intact and labels legible.
 - 5. Products are protected and undamaged.

1.17 PRODUCT HANDLING

- A. Provide equipment and personnel to handle products, including those provided by Owner, by methods to prevent soiling and damage.
- B. Provide additional protection during handling to prevent marring and otherwise damaging products, packaging and surrounding surfaces.
- C. Handle product by methods to avoid bending or over stressing. Lift large and heavy components only at designated lift points.

1.18 OPERATING AND MAINTENANCE MANUAL

- A. Refer to front portion of the specifications and to each Section of Division 26 Electrical.
- B. The Contractor shall furnish three (3) Operating and Maintenance Manuals to the Owner after all tests and adjustments have been completed. Final payment will not be

made until this manual has been submitted and approved. In addition to the requirements of Section 01700, The manual shall include, but is not limited to:

1. Name, Address and Telephone of the Manufacturer and Local Representative: Include a list of all suppliers and representatives of products supplied on the project shall be included in the manual.
2. Manufacturers' Manuals and Parts Lists: Operating and maintenance manuals and parts lists furnished by equipment manufacturers shall be included in the manual.
3. Manufacturers Start-up of Equipment Documentation: Documents shall include date and time of start-up, name of authorized personnel who performed start-up, any required settings and notes concerning start-up shall be included in the manual.
4. State or City Tests, Approval or Acceptance of Equipment and/or systems: This shall include date, time, name of authorized personnel and any other notes. Documentation of domestic water sterilization and equipment approved installation start-ups shall be included in the manual.
5. Shop Drawings: One copy of each approved shop drawing shall be included in the manual.
6. Index: A complete index shall be included at the front of the manual.
7. Binder: All of the above-described items shall be assembled in a three-ring binder with a hard cover and durable cloth or plastic finish.

1.19 STORAGE, GENERAL

- A. Store products, immediately on delivery, in accordance with manufacturer's instructions, with seals and labels intact. Protect until installed.
- B. Arrange storage in a manner to provide access for maintenance of stored items and for inspection.

1.20 CONFLICTS

- A. Conflicts between contract documents, codes ordinances or manufacturer's installation shall be brought to the attention of the Contracting Officer before installation for clarification.
- B. Conflicts not resolved prior to bid, the Contractor shall bid the larger quantity, more stringent or better quality of work.
- C. Where the codes or Utility Company requirements conflict with the drawings or specifications, the code shall have precedence only when it is more stringent than the item specified or shown. The item specified and/or shown on the drawings shall be followed when the item meets or exceed the required codes or Utility Company requirements.

PART 2 - PRODUCTS

2.1 MATERIALS AND EQUIPMENT

- A. Refer to front portion of the specifications.

- B. Materials and equipment for which only one manufacturer's name, model or catalog number is given, shall be used as a standard of quality. Other materials and equipment of equal quality and performance may be used and will be evaluated during shop drawing review. If during shop drawing review it is found to not be of equal quality and performance, then what was called out shall be provided. Materials and equipment specified to be one of two or more equally acceptable makes or types may be of any one of the makes of types mentioned, but shall be of one make or type throughout the project. Unless otherwise specified or shown, all materials shall be new and previously unused.

2.2 EQUIPMENT FINISH

- A. The exposed finished surface of most electrical equipment is finished at the factory and great care shall be exercised by the Contractor so as not to damage this original finish during the installation of the equipment. If the factory finish is damaged during construction and installation the equipment shall be refinished in equivalent factory finish in every respect including color, texture and smoothness of texture.

PART 3 - EXECUTION

3.1 TESTS AND ADJUSTMENTS

- A. After completion of the work, but before final payment is made, the Contractor shall run a test over a sufficient period of time to prove the proper operation and performance of all apparatus, etc. and of the system as a whole.

3.2 OPERATING INSTRUCTIONS

- A. After all tests and adjustments are completed, the Contractor shall give complete operating and maintenance instructions to the Owner's operating personnel. The Operating and Maintenance Manual shall be used as the basis of instructions.
- B. The Contractor shall notify Owner and Engineer seven (7) days prior to instructions.

3.3 CLEANING

- A. The Contractor shall maintain all areas free from hazardous or obstructive rubbish and debris due to installation of the electrical work during construction. When the electrical systems have been installed, the Contractor shall remove all rubbish and debris resulting from his work from the building and site and remove all paint, plaster and accumulated dirt from all electrical equipment, fixtures and conduit.
- B. After all equipment has been installed, the electrical contractor shall remove all stickers, rust stain labels, temporary covers, plaster marks, paint spots, etc. All foreign matter shall be blown out or flushed out of all piping, fans, motors, devices, switches, panels, etc.
- C. Identification plates on all equipment shall be free of excess paint and shall be varnished.
- D. The Contractor shall leave the electrical portion of the work in a safe, clean and very neat condition ready for operation.
- E. At completion of project, Contractor shall provide equipment identifications as directed in Section 26 0553.

3.4 PAINTING

- A. All painting shall be done pursuant to front portion of the specifications.
- B. Damage and Touch-up: Repair marred and damaged factory-painted finishes with materials and procedures to match original factory finish.

3.5 EQUIPMENT INSTALLATION

- A. Install equipment to allow maximum possible headroom unless specific mounting heights are indicated.
- B. Install equipment level and plumb, parallel and perpendicular to other building systems and components in exposed interior spaces, unless otherwise indicated.

3.6 ELECTRICAL WORK

- A. The Mechanical Contractor shall set in place all motors they are to furnish. All starters, switches, controls, etc., scheduled or provided with manufacturer equipment shall be turned over to the Electrical Contractor and they will be responsible for electrical connection.

END OF SECTION 26 0100

SECTION 26 0150 - BASIC ELECTRICAL MATERIALS AND METHODS

PART 1 - GENERAL

1.1 RELATED DOCUMENTS

- A. Drawings and general provisions of the Contract, including General and Supplementary Conditions and Division 1 Specification Sections, apply to this Section.

1.2 SUMMARY

- A. This Section includes the following:
 - 1. Supporting devices for electrical components.
 - 2. Concrete equipment bases.
 - 3. Electrical demolition.

1.3 DEFINITIONS

- A. EMT: Electrical metallic tubing.
- B. FMC: Flexible metal conduit.
- C. IMC: Intermediate metal conduit.
- D. LFMC: Liquidtight flexible metal conduit.
- E. RNC: Rigid nonmetallic conduit.

1.4 QUALITY ASSURANCE

- A. Electrical Components, Devices and Accessories: Listed and labeled as defined in NFPA 70, Article 100, by a testing agency acceptable to authorities having jurisdiction and marked for intended use.
- B. Comply with NFPA 70.

1.5 COORDINATION

- A. Coordinate chases, slots, inserts, sleeves and openings with general construction work and arrange in building structure during progress of construction to facilitate the electrical installations that follow.
 - 1. Set inserts and sleeves in poured-in-place concrete, masonry work and other structural components as they are constructed.
- B. Sequence, coordinate and integrate installing electrical materials and equipment for efficient flow of the Work. Coordinate installing large equipment requiring positioning before installing doors or closing up openings.
- C. Coordinate electrical service connections to components provided by utility companies.
 - 1. Comply with requirements of authorities having jurisdiction and of utility company providing electrical power and other services.

PART 2 - PRODUCTS

2.1 SUPPORTING DEVICES

- A. Material: Cold-formed steel, with corrosion-resistant coating acceptable to authorities having jurisdiction.
- B. Metal Items for Use Outdoors or in Damp Locations: Hot-dip galvanized steel.
- C. Slotted-Steel Channel Supports: Flange edges turned toward web and 9/16-inch-diameter slotted holes at a maximum of 2 inches o.c., in webs.
 - 1. Channel Thickness: Selected to suit structural loading.
 - 2. Fittings and Accessories: Products of the same manufacturer as channel supports.
- D. Raceway and Cable Supports: Manufactured clevis hangers, riser clamps, straps, threaded C-clamps with retainers, ceiling trapeze hangers, wall brackets and spring-steel clamps or click-type hangers.
- E. Cable Supports for Vertical Conduit: Factory-fabricated assembly consisting of threaded body and insulating wedging plug for nonarmored electrical cables in riser conduits. Plugs have number and size of conductor gripping holes as required to suit individual risers. Body constructed of malleable-iron casting with hot-dip galvanized finish.

2.2 CONCRETE BASES

- A. Concrete: 3000-psi, 28-day compressive strength.

PART 3 - EXECUTION

3.1 ELECTRICAL EQUIPMENT INSTALLATION

- A. Materials and Components: Install level, plumb and parallel and perpendicular to other building systems and components, unless otherwise indicated.
- B. Equipment: Install to facilitate service, maintenance and repair or replacement of components. Connect for ease of disconnecting, with minimum interference with other installations.
- C. Right of Way: Give to raceways and piping systems installed at a required slope.

3.2 WIRING INSTALLATION

- A. Install splices and taps that are compatible with conductor material and that possess equivalent or better mechanical strength and insulation ratings than unspliced conductors.
- B. Install wiring at outlets with at least 12 inches of slack conductor at each outlet.
- C. Connect outlet and component connections to wiring systems and to ground. Tighten electrical connectors and terminals, according to manufacturer's published torque-tightening values. If manufacturer's torque values are not indicated, use those specified in UL 486A.

3.3 ELECTRICAL SUPPORTING DEVICE APPLICATION

- A. Damp Locations and Outdoors: Hot-dip galvanized materials or nonmetallic, U-channel system components.
- B. Dry Locations: Steel materials.
- C. Support Clamps for PVC Raceways: Click-type clamp system.
- D. Selection of Supports: Comply with manufacturer's written instructions.
- E. Strength of Supports: Adequate to carry present and future loads, times a safety factor of at least four; minimum of 200-lb design load.

3.4 SUPPORT INSTALLATION

- A. Install support devices to securely and permanently fasten and support electrical components.

3.5 CONCRETE BASES

- A. Construct concrete bases of dimensions indicated. Follow supported equipment manufacturer's anchorage recommendations and setting templates for anchor-bolt and tie locations, unless otherwise indicated. Use 3000-psi, 28-day compressive-strength concrete and reinforcement.

3.6 DEMOLITION

- A. Protect existing electrical equipment and installations indicated to remain. If damaged or disturbed in the course of the Work, remove damaged portions and install new products of equal capacity, quality and functionality.
- B. Accessible Work: Remove exposed electrical equipment and installations, indicated to be demolished, in their entirety.
- C. Abandoned Work: Cut and remove buried raceway and wiring, indicated to be abandoned in place, 2 inches below the surface of adjacent construction. Cap raceways and patch surface to match existing finish.
- D. Remove demolished material from Project site.
- E. Remove, store, clean, reinstall, reconnect and make operational components indicated for relocation.

3.7 FIELD QUALITY CONTROL

- A. Inspect installed components for damage and faulty work, including the following:
 - 1. Raceways.
 - 2. Wire and connectors.
 - 3. Supporting devices for electrical components.
 - 4. Electrical identification.
 - 5. Concrete bases.
 - 6. Electrical demolition.

3.8 CLEANING AND PROTECTION

- A. On completion of installation, including fittings and devices, inspect exposed finish. Remove burrs, dirt, paint spots and construction debris.
- B. Protect equipment and installations and maintain conditions to ensure that coatings, finishes and cabinets are without damage or deterioration at time of Substantial Completion.

END OF SECTION 26 0150

SECTION 26 0519 - LOW-VOLTAGE ELECTRICAL POWER CONDUCTORS AND CABLES

PART 1 - GENERAL

1.1 SUMMARY

A. Section Includes:

1. Thermoplastic-insulated wire.
2. Thermoset-insulated wire.
3. Connectors and splices.

B. Related Requirements:

1. Section 26 0526 "Grounding and Bonding for Electrical Systems" specifies grounding and bonding referenced by this Section.
2. Section 26 0533 "Raceways and Boxes for Electrical Systems" specifies installation of raceways referenced by this Section.
3. Section 26 0553 "Identification for Electrical Systems" specifies electrical equipment labels and warning signs referenced by this Section.

1.2 DEFINITIONS

- A. NICET: National Institute for Certification in Engineering Technologies; a division of the National Society of Professional Engineers (NSPE).

1.3 ACTION SUBMITTALS

- A. Product Schedule: Indicate type, use, location, and termination locations.
- B. Product Data: For each type of product.
- C. Field quality-control reports.

1.4 INFORMATIONAL SUBMITTALS

- A. Manufacturer's published instructions.

PART 2 - PRODUCTS

2.1 PERFORMANCE REQUIREMENTS

- A. Regulatory Requirements: Products or components listed and labeled in accordance with NFPA 70, by qualified electrical testing laboratory recognized by authorities having jurisdiction, and marked for intended location and application.

2.2 THERMOPLASTIC-INSULATED WIRE

- A. Description: Thermoplastic-insulated wire for use in accordance with Article 310 of NFPA 70.
- B. UL ZLGR - Type THWN-2 Insulated Wire:
1. Listing Criteria: Investigated, labeled, and marked by qualified electrical testing laboratory in accordance with guide information and standards specified for the following UL product categories:

- a. Thermoplastic-Insulated Wire: UL CCN ZLGR, including UL 83.
- 2. Standard Features:
 - a. Referenced Standard: Article 310 of NFPA 70.
 - b. Insulation Voltage Rating: 600 V.
 - c. Insulation Temperature Rating: 90 deg C.
 - d. Conductor Material: Copper.
 - e. Conductor Size: As indicated on the Drawings.
 - 1) Minimum Conductor Size: 12 AWG.

2.3 THERMOSET-INSULATED WIRE

- A. Description: Thermoset-insulated wire for use in accordance with Article 310 of NFPA 70.
- B. UL ZKST - Type XHHW-2 Insulated Wire:
 - 1. Listing Criteria: Investigated, labeled, and marked by qualified electrical testing laboratory in accordance with guide information and standards specified for the following UL product categories:
 - a. Thermoset-Insulated Wire: UL CCN ZKST, including UL 44.
 - 2. Standard Features:
 - a. Referenced Standard: Article 310 of NFPA 70.
 - b. Insulation Voltage Rating: 600 V.
 - c. Insulation Temperature Rating: 90 deg C.
 - d. Conductor Material: Copper.
 - e. Conductor Size: As indicated on the Drawings.
 - 1) Minimum Conductor Size: 12 AWG.

2.4 CONNECTORS AND SPLICES

- A. UL ZMVV - Wire Connectors and Soldering Lugs:
 - 1. Description: Factory-fabricated connectors, splices, and lugs of size, ampacity rating, material, type, and class for application and service indicated; listed and labeled as defined in NFPA 70, by a qualified testing agency, and marked for intended location and use.
 - 2. Listing Criteria: Investigated, labeled, and marked by qualified electrical testing laboratory in accordance with guide information and standards specified for the following UL product categories:
 - a. Wire Connectors and Soldering Lugs: UL CCN ZMVV, including UL 486A-486B or UL 486C.
 - 3. Standard Features:

- a. One piece, seamless, designed to terminate conductors specified in this Section.
- b. Material: Copper.
- c. Type: Two hole with standard barrels.
- d. Termination: Compression.

PART 3 - EXECUTION

3.1 CONDUCTOR MATERIAL APPLICATIONS

A. Feeders:

1. Copper for feeders smaller than No. 4 AWG; copper or aluminum for feeders No. 4 AWG and larger. Conductors must be solid for No. 10 AWG and smaller; stranded for No. 8 AWG and larger.

B. Branch Circuits:

1. Material: Copper.
 - a. Solid for No. 10 AWG and smaller; stranded for No. 8 AWG and larger.

3.2 CONDUCTOR INSULATION AND MULTICONDUCTOR CABLE APPLICATIONS AND WIRING METHODS

- A. Service Entrance: Type XHHW-2, single conductors in raceway.
- B. Exposed Feeders: Type THHN/THWN-2, single conductors in raceway.
- C. Feeders Concealed in Concrete, below Slabs-on-Grade, and Underground: Type THHN/THWN-2, single conductors in raceway.
- D. Exposed Branch Circuits: Type THHN/THWN-2, single conductors in raceway.
- E. Branch Circuits Concealed in Concrete, below Slabs-on-Grade, and Underground: Type THHN/THWN-2, single conductors in raceway.

3.3 INSTALLATION OF LOW-VOLTAGE ELECTRICAL POWER CONDUCTORS AND CABLES

- A. Comply with manufacturer's published instructions.
- B. Reference Standards for Installation: Unless more stringent installation requirements are specified in the Contract Documents or manufacturer's published instructions, comply with the following:
 1. Electrical Construction: ICC IBC, ICC IFB, NFPA 1, NFPA 70, and NECA NEIS 1.
 2. Electrical Maintenance: NFPA 70B.
 3. Electrical Safety: NFPA 70E.
 4. Temporary Electric Power Work: NECA NEIS 200.
 5. Grounding and Bonding: NECA NEIS 331 and Article 250 of NFPA 70.
 6. Work in Confined Spaces: NFPA 350.

C. Special Installation Techniques:

1. Complete raceway installation between conductor and cable termination points prior to pulling conductors and cables.
2. Use manufacturer-approved pulling compound or lubricant where necessary; compound used must not deteriorate conductor or insulation. Do not exceed manufacturer's recommended maximum pulling tensions and sidewall pressure values.
3. Use pulling means, including fish tape, cable, rope, and basket-weave wire/cable grips, that will not damage cables or raceway.
4. Install exposed cables parallel and perpendicular to surfaces of exposed structural members, and follow surface contours where possible.
5. Provide support for cables.
6. Connections:
 - a. Tighten electrical connectors and terminals in accordance with manufacturer's published torque-tightening values. If manufacturer's torque values are not indicated, use those specified in UL 486A-486B.
 - b. Make splices, terminations, and taps that are compatible with conductor material and that possess equivalent or better mechanical strength and insulation ratings than unspliced conductors.
 - 1) Use oxide inhibitor in each splice, termination, and tap for aluminum conductors.

D. Interfaces with Other Work:

1. Identification:
 - a. Identify and color-code conductors and cables.
 - b. Identify each spare conductor at each end with identity number and location of other end of conductor, and identify as spare conductor.
2. Sleeves and Sleeve Seals: Install sleeves and sleeve seals at penetrations of wall assemblies.
3. Firestopping: Apply firestopping to electrical penetrations of fire-rated wall assemblies to restore original fire-resistance rating of assembly.

3.4 FIELD QUALITY CONTROL

A. Tests and Inspections:

1. After installing conductors and cables and before electrical circuitry has been energized, test service entrance and feeder conductors for compliance with requirements.
2. Perform each of the following visual and electrical tests:
 - a. Inspect exposed sections of conductor and cable for physical damage and correct connection in accordance with the single-line diagram.

- b. Test bolted connections for high resistance using one or more of the following:
 - 1) A low-resistance ohmmeter.
 - 2) Calibrated torque wrench.
 - 3) Thermographic survey.
 - c. Inspect compression-applied connectors for correct cable match and indentation.
 - d. Inspect for correct identification.
 - e. Inspect cable jacket and condition.
 - f. Insulation-resistance test on each conductor for ground and adjacent conductors. Apply a potential of 500 V(dc) for 300 V rated cable and 1000 V(dc) for 600 V rated cable for a one-minute duration.
 - g. Continuity test on each conductor and cable.
 - h. Uniform resistance of parallel conductors.
- B. Nonconforming Work:
- 1. Wire or cable assembly will be considered defective if it does not pass tests and inspections.
 - 2. Remove and replace defective units and retest.
- C. Field Quality-Control Reports: Collect, assemble, and submit test and inspection reports.

END OF SECTION 26 0519

SECTION 26 0526 - GROUNDING AND BONDING FOR ELECTRICAL SYSTEMS

PART 1 - GENERAL

1.1 SUMMARY

A. Section Includes:

1. Grounding and bonding conductors.
2. Grounding and bonding hubs.
3. Grounding and bonding connectors.
4. Grounding (earthing) electrodes.

B. Related Requirements:

1. Section 26 0553 "Identification for Electrical Systems" specifies electrical equipment labels and warning signs installed by this Section.

1.2 ACTION SUBMITTALS

- A. Product Data: For each type of product.

PART 2 - PRODUCTS

2.1 PERFORMANCE REQUIREMENTS

- A. Regulatory Requirements: Products or components listed and labeled in accordance with NFPA 70, by qualified electrical testing laboratory recognized by authorities having jurisdiction, and marked for intended location and application.
- B. Comply with UL 467 for grounding and bonding materials and equipment.

2.2 GROUNDING AND BONDING CONDUCTORS

A. Equipment Grounding Conductor:

1. Standard Features: 600 V, THHN/THWN-2, copper wire or cable, green color, in accordance with Section 26 0519 "Low-Voltage Electrical Power Conductors and Cables."

B. ASTM - Bare Copper Grounding and Bonding Conductor:

1. Standard Features: Complying with one or more of the following:
 - a. Soft or Annealed Copper Wire: ASTM B3.
 - b. Concentric-Lay Stranded Copper Conductor: ASTM B8.
 - c. Tin-Coated Soft or Annealed Copper Wire: ASTM B33.
 - d. 19-Wire Combination Unilay-Stranded Copper Conductor: ASTM B787/B787M.

2.3 GROUNDING AND BONDING HUBS

A. UL KDER - Grounding and Bonding Hub:

1. Source Limitations: Obtain products from single manufacturer.

2. Listing Criteria: Investigated, labeled, and marked by qualified electrical testing laboratory in accordance with guide information and standards specified for the following UL product categories:
 - a. Grounding and Bonding Equipment: UL CCN KDER; including UL 467.
3. Standard Features: Insulated, gasketed, watertight hub with mechanical-type wire terminal.

2.4 GROUNDING AND BONDING CONNECTORS

A. UL KDER - Pressure-Type Grounding and Bonding Busbar Cable Connector:

1. Source Limitations: Obtain products from single manufacturer.
2. Listing Criteria: Investigated, labeled, and marked by qualified electrical testing laboratory in accordance with guide information and standards specified for the following UL product categories:
 - a. Grounding and Bonding Equipment: UL CCN KDER; including UL 467.
 - b. Grounding and Bonding Equipment for Communications: UL CCN KDSH; including UL 467.
3. Standard Features: Copper or copper alloy, for compression bonding of one or more conductor directly to copper busbar. Listed for direct burial.

B. UL KDER - Crimped Pressure-Type Grounding and Bonding Cable Connector:

1. Source Limitations: Obtain products from single manufacturer.
2. Listing Criteria: Investigated, labeled, and marked by qualified electrical testing laboratory in accordance with guide information and standards specified for the following UL product categories:
 - a. Grounding and Bonding Equipment: UL CCN KDER; including UL 467.
 - b. Grounding and Bonding Equipment for Communications: UL CCN KDSH; including UL 467.
3. Standard Features: Crimp-and-compress connectors that bond to conductor when connector is compressed around conductor.
 - a. Copper, Copper alloy, C and H shaped.

2.5 GROUNDING (EARTHING) ELECTRODES

A. UL KDER - Rod Electrode:

1. Source Limitations: Obtain products from single manufacturer.
2. Listing Criteria: Investigated, labeled, and marked by qualified electrical testing laboratory in accordance with guide information and standards specified for the following UL product categories:
 - a. Grounding and Bonding Equipment: UL CCN KDER; including UL 467.
3. Standard Features: Copper-clad steel 5/8 inch by 8 ft.

PART 3 - EXECUTION

3.1 EXAMINATION

- A. Examine facility's grounding electrode system and equipment grounding for compliance with requirements for maximum ground-resistance level and other conditions affecting performance of grounding and bonding of electrical system.
- B. Inspect test results of grounding system measured at point of electrical service equipment connection.
- C. Prepare written report, endorsed by Installer, listing conditions detrimental to performance of the Work.
- D. Proceed with connection of electrical service equipment only after unsatisfactory conditions have been corrected.

3.2 SELECTION OF GROUNDING AND BONDING PRODUCTS

A. Grounding and Bonding Conductors:

- 1. Provide solid conductor for 8 AWG and smaller, and stranded conductors for 6 AWG and larger unless otherwise indicated.
- 2. Bonding Cable: 28 kcmil, 14 strands of 17 AWG conductor, 1/4 inch in diameter.
- 3. Bonding Conductor: 4 AWG or 6 AWG, stranded conductor.
- 4. Bonding Jumper: Copper tape, braided conductors terminated with copper ferrules; 1-5/8 inch wide and 1/16 inch thick.
- 5. Tinned Bonding Jumper: Tinned-copper tape, braided conductors terminated with copper ferrules; 1-5/8 inch wide and 1/16 inch thick.
- 6. Underground Grounding Conductors: Install bare copper conductor, 2/0 AWG minimum. (If required for this contract.)

B. Grounding and Bonding Connectors:

- 1. Pipe and Equipment Grounding Conductor Terminations: Bolted connectors.
- 2. Underground Connections: Welded connectors except at test wells and as otherwise indicated.
- 3. Connections to Ground Rods at Test Wells: Bolted connectors.
- 4. Connections to Structural Steel: Welded connectors.

3.3 INSTALLATION OF GROUNDING AND BONDING

A. Comply with manufacturer's published instructions.

B. Reference Standards:

- 1. Electrical Construction: ICC IBC, ICC IFC, NFPA 1, NFPA 70, and NECA NEIS 1.
- 2. Electrical Maintenance: NFPA 70B.
- 3. Electrical Safety: NFPA 70E.

4. Grounding and Bonding: NECA NEIS 331 and Article 250 of NFPA 70.
 5. Communications Work: BICSI N1.
 6. Emergency and Standby Power Work: NFPA 110, NFPA 111, and NECA NEIS 416.
 7. Work in Confined Spaces: NFPA 350.
- C. Special Techniques:
1. Grounding and Bonding Conductors:
 - a. Route along shortest and straightest paths possible unless otherwise indicated or required by Code. Avoid obstructing access or placing conductors where they may be subjected to strain, impact, or damage.
 - b. Underground Grounding Conductors:
 - 1) Bury at least 30 inch below grade.
 2. Grounding and Bonding Connectors: Make connections so possibility of galvanic action or electrolysis is minimized. Select connectors, connection hardware, conductors, and connection methods so metals in direct contact are galvanically compatible.
 - a. Use electroplated or hot-tin-coated materials to ensure high conductivity and to make contact points closer in order of galvanic series.
 - b. Make connections with clean, bare metal at points of contact.
 - c. Make aluminum-to-steel connections with stainless steel separators and mechanical clamps.
 - d. Make aluminum-to-galvanized-steel connections with tin-plated copper jumpers and mechanical clamps.
 - e. Coat and seal connections having dissimilar metals with inert material to prevent future penetration of moisture to contact surfaces.
 - f. Bonding Straps and Jumpers: Install in locations accessible for inspection and maintenance except where routed through short lengths of conduit.
 - 1) Bonding to Structure: Bond straps directly to basic structure, taking care not to penetrate adjacent parts.
 - 2) Bonding to Equipment Mounted on Vibration Isolation Hangers and Supports: Install bonding so vibration is not transmitted to rigidly mounted equipment.
 - 3) Use exothermic-welded connectors for outdoor locations; if disconnect-type connection is required, use bolted clamp.
 3. Electrodes:
 - a. Ground Rods: Drive rods until tops are 2 inch below finished floor or final grade unless otherwise indicated.

- 1) Interconnect ground rods with grounding electrode conductor below grade and as otherwise indicated. Make connections without exposing steel or damaging coating if any.
- 2) Use exothermic welds for below-grade connections.
- b. Concrete-Encased Electrode (Ufer Ground):
 - 1) Fabricate in accordance with NFPA 70; use minimum of 20 ft of bare copper conductor not smaller than 4 AWG.
 - a) If concrete foundation is less than 20 ft long, coil excess conductor within base of foundation.
 - b) Bond grounding conductor to reinforcing steel in at least four locations and to anchor bolts. Extend grounding conductor below grade and connect to grounding electrode external to concrete.
 - 2) Fabricate in accordance with NFPA 70; using electrically conductive coated steel reinforcing bars or rods, at least 20 ft long. If reinforcing is in multiple pieces, connect together by usual steel tie wires or exothermic welding to create required length.
4. Grounding at Service:
 - a. Equipment grounding conductors and grounding electrode conductors must be connected to ground busbar. Install main bonding jumper between neutral and ground buses.
5. Equipment Grounding and Bonding:
 - a. Install insulated equipment grounding conductors with feeders and branch circuits.

3.4 FIELD QUALITY CONTROL FOR GROUNDING AND BONDING

A. Tests and Inspections:

1. After installing grounding system but before permanent electrical circuits have been energized, test for compliance with requirements.
2. Inspect physical and mechanical condition. Verify tightness of accessible, bolted, electrical connections with calibrated torque wrench in accordance with manufacturer's published instructions.
3. Test completed grounding system at each location where maximum ground-resistance level is specified, at service disconnect enclosure grounding terminal, at ground test wells. Make tests at ground rods before conductors are connected.
 - a. Measure ground resistance no fewer than two full days after last trace of precipitation and without soil being moistened by means other than natural drainage or seepage and without chemical treatment or other artificial means of reducing natural ground resistance.
 - b. Perform tests by fall-of-potential method in accordance with IEEE Std 81.

- c. Excessive Ground Resistance: If resistance to ground exceeds specified values, notify Engineer promptly and include recommendations to reduce ground resistance.
 - B. Nonconforming Work:
 - 1. Grounding system will be considered defective if it does not pass tests and inspections.
 - 2. Remove and replace defective components and retest.
 - C. Collect, assemble, and submit test and inspection reports.
 - 1. Report measured ground resistances that exceed the following values:
 - a. Power and Lighting Equipment or System with Capacity of 500 kVA and Less: 10 Ω .
 - b. Individual Ground Rods: 25 Ω .
- 3.5 PROTECTION
- A. After installation, protect grounding and bonding cables and equipment from construction activities. Remove and replace items that are contaminated, defaced, damaged, or otherwise caused to be unfit for use prior to acceptance by Owner.

END OF SECTION 26 0526

SECTION 26 0533 - RACEWAY AND BOXES FOR ELECTRICAL SYSTEMS

PART 1 - GENERAL

1.1 SUMMARY

A. Section Includes:

1. Type PVC raceways and fittings.
2. Fittings for conduit, tubing, and cable.
3. Solvent cements.

1.2 ACTION SUBMITTALS

A. Product Data: For the following:

1. Raceways.

PART 2 - PRODUCTS

2.1 TYPE PVC RACEWAYS AND FITTINGS

A. Schedule 40 Rigid PVC Conduit (PVC-40) and Fittings:

1. Applicable Standards:

- a. Regulatory Requirements: Listed and labeled in accordance with NFPA 70 and marked for intended location and use.
- b. General Characteristics:
 - 1) Reference Standards: UL 651 and UL Category Control Number DZYR.
 - 2) Dimensional Specifications: Schedule 40.
- c. Options:
 - 1) Minimum Trade Size: 3/4 inch.

B. Schedule 80 Rigid PVC Conduit (PVC-80) and Fittings:

1. Applicable Standards:

- a. Regulatory Requirements: Listed and labeled in accordance with NFPA 70 and marked for intended location and use.
- b. General Characteristics:
 - 1) Reference Standards: UL 651 and UL Category Control Number DZYR.
 - 2) Dimensional Specifications: Schedule 80.
- c. Options:
 - 1) Minimum Trade Size: 3/4 inch.

2.2 FITTINGS FOR CONDUIT

A. Fittings for Type PVC Raceways:

1. Applicable Standards:

- a. Regulatory Requirements: Listed and labeled in accordance with NFPA 70 and marked for intended location and use.
- b. General Characteristics:
 - 1) Reference Standards: UL 514B and UL Category Control Number DWTT.
 - 2) Material: Steel.
 - 3) Coupling Method: Compression coupling .
- c. Options:
 - 1) Expansion and Deflection Fittings: UL 651 with flexible external bonding jumper.

2.3 SOLVENT CEMENTS

A. Solvent Cements for Type PVC Raceways and Fittings:

1. Applicable Standards:

a. General Characteristics:

- 1) Reference Standards: As recommended by conduit manufacturer in accordance with UL 514B and UL Category Control Number DWTT.

PART 3 - EXECUTION

3.1 SELECTION OF RACEWAYS

A. Unless more stringent requirements are specified in Contract Documents or manufacturers' written instructions, comply with NFPA 70 for selection of raceways. Consult Engineer for resolution of conflicting requirements.

B. Outdoors:

1. Direct-Buried Conduit: PVC-40, PVC-80 (Utility side).

3.2 INSTALLATION OF RACEWAYS

A. Installation Standards:

1. Unless more stringent requirements are specified in Contract Documents or manufacturers' written instructions, comply with NFPA 70 for installation of raceways. Consult Engineer for resolution of conflicting requirements.
2. Comply with NFPA 70 limitations for types of raceways allowed in specific occupancies and number of floors.
3. Comply with NECA NEIS 101 for installation of steel raceways.
4. Comply with NECA NEIS 111 for installation of nonmetallic raceways.

5. Install raceways square to the enclosure and terminate at enclosures without hubs with locknuts on both sides of enclosure wall. Install locknuts hand tight, plus one-quarter turn more.
 6. Terminate threaded conduits into threaded hubs or with locknuts on inside and outside of boxes or cabinets. Install bushings on conduits up to 1-1/4 inch trade size and insulated throat metal bushings on 1-1/2 inch trade size and larger conduits terminated with locknuts. Install insulated throat metal grounding bushings on service conduits.
- B. General Requirements for Installation of Raceways:
1. Complete raceway installation before starting conductor installation.
 2. Support within 12 inch of changes in direction.
 3. Make bends in raceway using large-radius preformed ells except for parallel bends. Field bending must be in accordance with NFPA 70 minimum radii requirements. Provide only equipment specifically designed for material and size involved.
 4. Install conduits parallel or perpendicular to structure lines.
 5. Support conduit within 12 inch of enclosures to which attached.
 6. Cut conduit perpendicular to the length. For conduits 2 inch trade size and larger, use roll cutter or a guide to make cut straight and perpendicular to the length. Ream inside of conduit to remove burrs.
 7. Install pull wires in empty raceways. Provide polypropylene or monofilament plastic line with not less than 200 lb tensile strength. Leave at least 12 inch of slack at both ends of pull wire. Cap underground raceways designated as spare above grade alongside raceways in use.
- C. Requirements for Installation of Specific Raceway Types:
1. Types PVC:
 - a. Comply with manufacturer's written instructions for solvent welding and fittings.
- D. Raceway Fittings: Install fittings in accordance with NEMA FB 2.10 guidelines.
- ### 3.3 PROTECTION
- A. Protect coatings, finishes, and cabinets from damage and deterioration.
1. Repair damage to galvanized finishes with zinc-rich paint recommended by manufacturer.
 2. Repair damage to PVC coatings or paint finishes with matching touchup coating recommended by manufacturer.
- ### 3.4 CLEANING
- A. Boxes: Remove construction dust and debris from device boxes, enclosures before installing covers.

END OF SECTION 26 0533

SECTION 26 05 53 - IDENTIFICATION FOR ELECTRICAL SYSTEMS

PART 1 - GENERAL

1.1 SUMMARY

A. Section Includes:

1. Labels.
2. Tapes.
3. Signs.

1.2 ACTION SUBMITTALS

- A. Product Data: For each type of product.
- B. Identification Schedule: For each piece of electrical equipment and electrical system components to be index of nomenclature for electrical equipment and system components used in identification signs and labels. Use same designations indicated on Drawings.

PART 2 - PRODUCTS

2.1 LABELS

A. Performance Criteria:

1. Regulatory Requirements: Listed and labeled in accordance with NFPA 70, by qualified electrical testing laboratory recognized by authorities having jurisdiction, and marked for intended location and application.
2. Listing Criteria: UL CCN PGDQ2 for components; including UL 969.

B. UL PGDQ2 - Vinyl Wraparound Labels: Preprinted, flexible labels laminated with clear, weather- and chemical-resistant coating and matching wraparound clear adhesive tape for securing label ends.

C. UL PGDQ2 - Self-Adhesive Wraparound Labels: Preprinted, 3 mil thick, vinyl flexible label with acrylic pressure-sensitive adhesive.

1. Self-Lamination: Clear; UV-, weather-, and chemical-resistant; self-laminating, with protective shield over legend. Size labels such that clear shield overlaps entire printed legend.
2. Marker for Labels:
 - a. Permanent, waterproof, black ink marker recommended by tag manufacturer.

D. UL PGDQ2 - Self-Adhesive Labels: Vinyl, thermal, transfer-printed, 3 mil thick, multicolor, weather- and UV-resistant, pressure-sensitive adhesive labels, configured for intended use and location.

1. Minimum Nominal Size:
 - a. 1-1/2 by 6 inch for raceway and conductors.

- b. 3-1/2 by 5 inch for equipment.
- c. As required by authorities having jurisdiction.

2.2 TAPES

- A. Marker Tapes: Vinyl or vinyl-cloth, self-adhesive wraparound type, with circuit identification legend machine printed by thermal transfer or equivalent process.
- B. Self-Adhesive Vinyl Tape: Colored, heavy duty, waterproof, fade resistant; not less than 3 mil thick by 1 to 2 inch wide; compounded for outdoor use.
- C. Underground-Line Warning Tape:
 - 1. Tape:
 - a. Recommended by manufacturer for method of installation and suitable to identify and locate underground electrical and communications utility lines.
 - b. Printing on tape must be permanent and may not be damaged by burial operations.
 - c. Tape material and ink must be chemically inert and not be subject to degradation when exposed to acids, alkalis, and other destructive substances commonly found in soils.
 - 2. Color and Printing:
 - a. Comply with APWA Uniform Color Code using NEMA Z535.1 safety colors.
 - b. Inscriptions for Red Tapes: "CAUTION BURIED ELECTRIC LINE BELOW".
 - c. Inscriptions for Orange Tapes: "CAUTION BURIED COMMUNICATION LINE BELOW".
 - 3. Nonconducting Line-Warning Tape:
 - a. Pigmented polyolefin, bright colored, continuous-printed on one side with inscription of utility, compounded for direct-burial service.
 - b. Width: 3 inch.
 - c. Thickness: 4 mil.
 - d. Weight: 18.5 lb/1000 sq. ft.
 - e. Tensile in accordance with ASTM D882: 30 lbf and 2500 psi.

2.3 SIGNS

- A. Laminated Acrylic or Melamine Plastic Signs:
 - 1. Engraved legend.
 - 2. Thickness:
 - a. For signs up to 20 sq. inch, minimum 1/16 inch thick.
 - b. For signs larger than 20 sq. inch, 1/8 inch thick.
 - c. Engraved legend with black letters on white face.

- d. Punched or drilled for mechanical fasteners with 1/4 inch grommets in corners for mounting.
- e. Framed with mitered acrylic molding and arranged for attachment at applicable equipment.

PART 3 - EXECUTION

3.1 PREPARATION

- A. Self-Adhesive Identification Products: Before applying electrical identification products, clean substrates of substances that could impair bond, using materials and methods recommended by manufacturer of identification product.

3.2 SELECTION OF COLORS AND IDENTIFICATION MARKINGS

- A. Color-Coding for Phase- and Voltage-Level Identification, 1000 V or Less: Use colors listed below for ungrounded service feeder and branch-circuit conductors.
 - 1. Color must be factory applied or field applied for sizes larger than 8 AWG when permitted by authorities having jurisdiction.
 - 2. Colors for 240 V Circuits:
 - a. Phase A: Black.
 - b. Phase B: Red.
 - 3. Color for Neutral (Grounded Conductor): White or gray.
 - 4. Color for Equipment Ground: Green.
 - 5. Color for Isolated Ground: Green with two or more yellow stripes.
- B. Color-Coding Raceways, Cable Trays, Junction Boxes, and Conductors for Intrinsically-Safe Circuits: Light blue. When used to identify intrinsically-safe circuits, Article 504 of NFPA 70 requires that the color light blue not be used for any other purpose.
- C. Color-Coding Instructional Signs: Self-adhesive labels, including color code for grounded and ungrounded conductors.
- D. Identify conductors, cables, and terminals in enclosures and at junctions, terminals, pull points, and locations of high visibility. Identify by system and circuit designation.
- E. Locations of Underground Lines: Underground-line warning tape for power and lighting.
- F. Equipment Identification Labels:
 - 1. Black letters on white field.
 - 2. Outdoor Equipment: Laminated acrylic or melamine sign.
 - 3. Equipment to Be Labeled:
 - a. Panelboards: Typewritten directory of circuits in location provided by panelboard manufacturer. Panelboard identification must be in form of engraved, laminated acrylic or melamine label.
 - b. Enclosures and electrical cabinets.

- c. Access doors and panels for concealed electrical items.

3.3 INSTALLATION

- A. Install identification materials and devices at locations for most convenient viewing without interference with operation and maintenance of equipment. Install access doors or panels to provide view of identifying devices.
- B. Verify and coordinate identification names, abbreviations, colors, and other features with requirements in other Sections requiring identification applications, Drawings, Shop Drawings, manufacturer's wiring diagrams, and operation and maintenance manual. Use consistent designations throughout Project.
- C. Verify identity of item before installing identification products.
- D. Coordinate identification with Project Drawings, manufacturer's wiring diagrams, and operation and maintenance manual.
- E. Apply identification devices to surfaces that require finish after completing finish work.
- F. Install signs with approved legend to facilitate proper identification, operation, and maintenance of electrical systems and connected items.
- G. Vinyl Wraparound Labels:
 - 1. Secure tight to surface of raceway or cable at location with high visibility and accessibility.
 - 2. Attach labels that are not self-adhesive type with clear vinyl tape, with adhesive appropriate to location and substrate.
- H. Self-Adhesive Wraparound Labels: Secure tight to surface at location with high visibility and accessibility.
- I. Marker Tapes: Secure tight to surface at location with high visibility and accessibility.
- J. Self-Adhesive Vinyl Tape: Secure tight to surface at location with high visibility and accessibility.
 - 1. Field-Applied, Color-Coding Conductor Tape: Apply in half-lapped turns for minimum distance of 6 inch where splices or taps are made. Apply last two turns of tape with no tension to prevent possible unwinding.
- K. Underground Line Warning Tape:
 - 1. During backfilling of trenches, install continuous underground-line warning tape not less than 12 inch directly above cables or raceways buried 18 inch or more below grade. Use multiple tapes where width of multiple lines installed in common trench exceeds 16 inch overall.
 - 2. Limit use of underground-line warning tape to direct-buried cables.
- L. Laminated Acrylic or Melamine Plastic Signs: Attach signs that are not self-adhesive type with mechanical fasteners appropriate to location and substrate.

END OF SECTION 26 05 53

SECTION 31 2300 – EXCAVATION AND FILL

PART 1 - GENERAL

1.1 SUMMARY

- A. This Section shall consist of excavation, embankment fill, disposal of excess material, shaping, and compaction of all material encountered within the limits of Work, including excavation and fill for structures. The excavation shall include, but is not limited to, the native soils which shall be excavated for the Project Work. All Work shall be completed in accordance with these Specifications, the lines and grades, and typical cross-sections shown on the Drawings.
- B. Section Includes:
 - 1. Soil densification.
 - 2. Excavating for paving.
 - 3. Excavating for site structures.
- C. Related Sections:
 - 1. Section 31 2333 – Trenching and Backfilling

1.2 REFERENCES

- A. Local utility standards when working within 24 inches of utility lines.
- B. ASTM International (ASTM):
 - 1. D698, Standard Test Methods for Laboratory Compaction Characteristics of Soil Using Standard Effort (12 400 ft-lbf/ft³ (600 kN-m/m³)).
 - 2. D4253, Standard Test Methods for Maximum Index Density and Unit Weight of Soils Using a Vibratory Table.
- C. Occupational Safety and Health Administration (OSHA).

1.3 QUALITY ASSURANCE

- A. Perform Work according to City of Thornton standards.

PART 2 - PRODUCTS

2.1 MATERIALS

- A. Embankment Material may consist of approved material acquired from excavations or material hauled from outside the Project limits.
- B. Suitable material identified onsite shall be used first for embankments and backfill.
- C. Excess excavated native soils which are not used as embankment or backfill shall become the property of the Contractor and shall be disposed of offsite by Contractor, in a location acceptable to the Engineer.
- D. Muck Excavation shall also include the replacement of excavated muck with uniformly graded rock, riprap, onsite or imported soils, or other material, whichever is most

suitable for the specific situation encountered as required in Section 31 2333
“Trenching and Backfilling.”

- E. Engineer will determine which type of aggregate or other material which shall be used after observing the specific site conditions.
- F. When specified on the Drawings or as required by Engineer, Class I structural backfill shall meet the gradation requirements as required in Section 31 2333 “Trenching and Backfilling.”

PART 3 - EXECUTION

3.1 PREPARATION

- A. Utility Service Locator:
 - 1. Call local utility service-line information not less than three working days before performing Work.
 - 2. Request that underground utilities be located and marked within and immediately surrounding construction areas.
 - 3. Identify required lines, levels, contours, and data.
- B. Existing Utilities:
 - 1. Notify utility companies to remove and relocate utilities.
 - 2. Protect from damage utilities indicated to remain.
- C. Protect plant life, lawns, and other features designated to remain as portion of final landscaping.
- D. Protect benchmarks, survey control points , existing structures , fences , sidewalks, paving curbs, and other items designated to remain from excavating equipment and vehicular traffic.
- E. Do not close or obstruct roadways, sidewalks, or existing utilities without permission from Owner/Engineer.
- F. Erect and maintain temporary barriers and security devices, including warning signs, warning lights, and similar measures, for protection of public , Owner , and existing improvements indicated to remain.

3.2 EXCAVATION

- A. Underpin adjacent structures which may be damaged by excavation Work.
- B. Excavate subsoil to accommodate building foundations , slabs on grade , paving , Site structures, and construction operations.
- C. Excavate to working elevation for piling Work.
- D. Compact disturbed load-bearing soil in direct contact with foundations to original bearing capacity, as specified in Section 31 2323.33 – Flowable Fill and Section 31 2333 – Trenching and Backfilling
- E. Slope banks with machine to angle of repose or less until shored.
- F. Do not interfere with 45-degree bearing splay of foundations.

- G. Grade top perimeter of excavation to prevent surface water from draining into excavation.
 - H. Trim excavation and remove loose matter.
 - I. Removal of Deleterious Materials:
 - 1. Remove lumped subsoil, boulders, and rock up to 1/3 cu. yd, measured by volume.
 - 2. Remove excess and unsuitable material from Site.
 - J. Notify Engineer of unexpected subsurface conditions.
 - K. Remove excavated material from Site.
 - L. Repair or replace items indicated to remain that have been damaged by excavation.
- 3.3 FIELD QUALITY CONTROL
- A. Inspecting: Request visual inspection of bearing surfaces by Engineer before installing subsequent Work.
- 3.4 PROTECTION
- A. Prevent displacement or loose soil from falling into excavation, and maintain soil stability.
 - B. Protect bottom of excavations and soil adjacent to and beneath foundation from freezing.
 - C. Protect structures, utilities, and other facilities from damage caused by settlement, lateral movement, undermining, washout, and other hazards that may be created by earth operations.

END OF SECTION 31 2316

SECTION 31 2319 - DEWATERING

PART 1 - GENERAL

1.1 SUMMARY

- A. Section Includes:
1. Construction dewatering.

1.2 FIELD CONDITIONS

- A. Project-Site Information: A geotechnical report has been prepared for this Project and is available for information only. The opinions expressed in this report are those of a geotechnical engineer and represent interpretations of subsoil conditions, tests, and results of analyses conducted by a geotechnical engineer. Owner is not responsible for interpretations or conclusions drawn from this data.
1. Make additional test borings and conduct other exploratory operations necessary for dewatering in accordance with the performance requirements.
 2. The geotechnical report is included in the Appendix of the Project Manual.
- B. Survey Work: Engage a qualified land surveyor or professional engineer to survey adjacent existing buildings, structures, and site improvements; establish exact elevations at fixed points to act as benchmarks. Clearly identify benchmarks and record existing elevations.

PART 2 - PRODUCTS

2.1 PERFORMANCE REQUIREMENTS

- A. Dewatering Performance: Design, furnish, install, test, operate, monitor, and maintain dewatering system of sufficient scope, size, and capacity to control hydrostatic pressures and to lower, control, remove, and dispose of groundwater and permit excavation and construction to proceed on dry, stable subgrades.
1. Design dewatering system, including comprehensive engineering analysis by a qualified professional engineer.
 2. Continuously monitor and maintain dewatering operations to ensure erosion control, stability of excavations and constructed slopes, prevention of flooding in excavation, and prevention of damage to subgrades and permanent structures.
 3. Prevent surface water from entering excavations by grading, dikes, or other means.
 4. Accomplish dewatering without damaging existing buildings, structures, and site improvements adjacent to excavation.
 5. Water shall be disposed of in accordance with the requirements specified by the CDPS General Permit for Construction Dewatering Activities.
 6. Remove dewatering system when no longer required for construction.
- B. Regulatory Requirements: Comply with governing State and EPA notification regulations before beginning dewatering.

PART 3 - EXECUTION

3.1 PREPARATION

- A. Protect structures, utilities, sidewalks, pavements, and other facilities from damage caused by settlement, lateral movement, undermining, washout, and other hazards created by dewatering operations.
 - 1. Prevent surface water and subsurface or groundwater from entering excavations, from ponding on prepared subgrades, and from flooding site or surrounding area.
 - 2. Protect subgrades and foundation soils from softening and damage by rain or water accumulation.
- B. Install dewatering system to ensure minimum interference with roads, streets, walks, and other adjacent occupied and used facilities.
 - 1. Do not close or obstruct streets, walks, or other adjacent occupied or used facilities without permission from Owner and authorities having jurisdiction. Provide alternate routes around closed or obstructed traffic ways if required by authorities having jurisdiction.
- C. Provide temporary grading to facilitate dewatering and control of surface water.
- D. Protect and maintain temporary erosion and sedimentation controls, which are specified in Section 31 2500 "Erosion and Sedimentation Controls," during dewatering operations.

3.2 INSTALLATION

- A. Install dewatering system utilizing wells, well points, or similar methods complete with pump equipment, standby power and pumps, filter material gradation, valves, appurtenances, water disposal, and surface-water controls.
 - 1. Space well points or wells at intervals required to provide sufficient dewatering.
 - 2. Use filters or other means to prevent pumping of fine sands or silts from the subsurface.
- B. Place dewatering system into operation to lower water to specified levels before excavating below groundwater level.
- C. Provide sumps, sedimentation tanks, and other flow-control devices as required by authorities having jurisdiction.
- D. Provide standby equipment on-site, installed and available for immediate operation, to maintain dewatering on continuous basis if any part of system becomes inadequate or fails.

3.3 OPERATION

- A. Operate system continuously until drains, sewers, and structures have been constructed and fill materials have been placed or until dewatering is no longer required.
- B. Operate system to lower and control groundwater to permit excavation, construction of structures, and placement of fill materials on dry subgrades. Drain water-bearing strata above and below bottom of foundations, drains, sewers, and other excavations.

1. Do not permit open-sump pumping that leads to loss of fines, soil piping, subgrade softening, and slope instability.
 2. Reduce hydrostatic head in water-bearing strata below subgrade elevations of foundations, drains, sewers, and other excavations.
- C. Dispose of water removed by dewatering in a manner that avoids endangering public health, property, and portions of work under construction or completed. Dispose of water and sediment in a manner that avoids inconvenience to others.
- D. Remove dewatering system from Project site on completion of dewatering. Plug or fill well holes with sand or cut off and cap wells a minimum of 36 inches below overlying construction.

3.4 FIELD QUALITY CONTROL

- A. Observation Wells: Provide observation wells or piezometers, take measurements, and maintain at least the minimum number indicated; additional observation wells may be required by authorities having jurisdiction.
1. Observe and record daily elevation of groundwater and piezometric water levels in observation wells.
 2. Repair or replace, within 24 hours, observation wells that become inactive, damaged, or destroyed. In areas where observation wells are not functioning properly, suspend construction activities until reliable observations can be made. Add or remove water from observation-well risers to demonstrate that observation wells are functioning properly.
 3. Fill observation wells, remove piezometers, and fill holes when dewatering is completed.
- B. Provide continual observation to ensure that subsurface soils are not being removed by the dewatering operation.
- C. Prepare reports of observations.

3.5 PROTECTION

- A. Protect and maintain dewatering system during dewatering operations.
- B. Promptly repair damages to adjacent facilities caused by dewatering.

END OF SECTION 31 2319

SECTION 31 2323.33 - FLOWABLE FILL

PART 1 - GENERAL

1.1 SUMMARY

- A. Contractor shall furnish and place controlled low strength material (CLSM) backfill where shown in the Drawings. The pipeline trench shall be excavated to the proper lines, grades, and dimensions, pipe or structures installed, bedding installed and CLSM placed from bedding to top of pavement subgrade.

1.2 RELATED SECTIONS

- A. The following is a list of Specifications which may be related to this section:
 - 1. Section 31 2319, Dewatering.
 - 2. Section 31 2333, Trenching and Backfilling.

1.3 REFERENCES

- A. The following is a list of standards which may be referenced in this section:
 - 1. ASTM International (ASTM):
 - a. C33, Standard Specification for Concrete Aggregates.
 - b. C143/C143M, Standard Test Method for Slump of Hydraulic-Cement Concrete.
 - c. C150, Standard Specification for Portland Cement.
 - d. C494/C494M Rev A, Standard Specification for Chemical Admixtures for Concrete.
 - e. C618, Standard Specification for Coal Fly Ash and Raw or Calcined Natural Pozzolan for Use in Concrete.
 - f. D4832, Standard Test Method for Preparation and Testing of Controlled Low Strength (CLSM) Test Cylinders.
 - g. D5971, Standard Practice for Sampling Freshly Mixed Controlled Low-Strength Material.
 - h. D6023, Standard Test Method for Density (Unit Weight), Yield, Cement Content, and Air Content (Gravimetric) of Controlled Low-Strength Material (CLSM).
 - i. D6024, Standard Test Method for Ball Drop on Controlled Low-Strength Material (CLSM) to Determine Suitability for Load Application.
 - j. D6103, Standard Test Method for Flow Consistency of Controlled Low-Strength Material (CLSM).

1.4 SUBMITTALS

- A. Product data: Submit data completely describing materials in the mix and demonstrating compliance with the requirements of this Section a minimum of two (2) days prior to starting CLSM WORK.

1. Cement: Mill tests. Indicate alkali content representative of each shipment.
2. Fly Ash: Identify source and type of fly ash.
3. Water: Identify source and quality if not from a municipal treatment source.
4. Admixtures: Manufacturer's product data indicating suitability for use in CLSM mixes and recommended dosage rates.
5. Aggregate: Source, type, and sieve analyses. Resubmit at any time there is a significant change in grading of materials.

PART 2 - PRODUCTS

2.1 MATERIALS

A. General:

1. The CLSM bedding shall consist of a mixture of sand, coarse aggregate, cement and water.
2. Fly ash and approved admixtures may be used to obtain the required properties of the mix.
3. The mix shall have good workability and flowability with self-compacting and self-leveling characteristics.
4. No changes shall be made in the amounts or sources of the approved mix ingredients without the approval of Engineer.
5. Product inspection and field-testing of the approved mix may be made by, or on behalf of, Owner.

B. Cement: All cement used shall be Type II Portland cement which shall conform to the requirements of ASTM C150.

C. Fly Ash: Fly ash may be either Class C or Class F. The fly ash shall conform to ASTM C618.

D. Aggregates:

- a. Fine Aggregate: All fine aggregate shall conform to the grading and quality requirements of ASTM C33.
- b. Coarse Aggregate: Coarse aggregate shall conform to the grading and quality requirements of ASTM C33 for size No. 476, No. 57, or No. 67.

E. Water: The batch mixing water and mixer washout water shall conform to the requirements of ASTM C94.

F. Admixtures:

1. Chemical admixtures that do not contain calcium chloride and conform to ASTM C494/C494M for concrete may be used in the CLSM mix.
2. All chemical admixtures shall be compatible with the cement and all other admixtures in the batch.

G. CLSM Proportions:

1. Strength: CLSM shall have a minimum twenty-eight (28) day compressive strength of one hundred (100) psi when molded and cured as in conformance with ASTM D4832.
2. The CLSM shall have a minimum cement content of fifty (50) pounds per cubic yard. The water-cementitious materials ratio of the mix shall not exceed three and one-half to one (3.5:1).
3. Air-Entrainment: All CLSM shall be air entrained to a total air content of approximately five percent (5%).
4. Slump: The minimum slump shall be six (6) inches and the maximum slump shall be eight (8) inches when tested in accordance with ASTM D6103.
5. Aggregate: Fine aggregate shall be between fifty percent (50%) and sixty percent (60%) by volume of the total aggregates in the CLSM mix.
6. Consistency:
 - a. The consistency of the CLSM slurry shall be such that the material flows easily into all openings between the pipe and the lower portion of the trench.
 - b. When trenches are on a steep slope, a stiffer mix of slurry may be required to prevent CLSM from flowing down the trench.
 - c. When a stiffer mix is used, vibration shall be performed to ensure that the CLSM slurry completely fills all spaces between the pipe and the lower portion of the trench.

PART 3 - EXECUTION

3.1 GENERAL

- A. CLSM shall be placed as closely behind pipe laying operations as possible.
- B. CLSM shall not be placed, if, in the judgment of ENGINEER, weather conditions are unsuitable.
- C. CLSM shall not be placed when the trench bottom or walls are frozen or contain frozen materials.
- D. CLSM shall not be placed when the air temperature is below forty degrees Fahrenheit (40°F) unless the air temperature is thirty-five degrees Fahrenheit (35°F) or more and the temperature is rising.

3.2 PLACEMENT

- A. CLSM shall be deposited as nearly as practical in its final position and in no way disturb the pipe trench or cause foreign material to become mixed with the CLSM.
- B. Soil backfill or asphalt shall not be placed until the CLSM has reached the initial set.
 1. If backfill or asphalt is not to be placed over the CLSM within eight (8) hours, a six-inch (6") cover of moist earth shall be placed over the CLSM surface.
 2. If the air temperature is fifty degrees Fahrenheit (50°F) or less, CLSM shall be adequately protected.

END OF SECTION 31 2323.33

SECTION 31 2316.13 – TRENCHING AND BACKFILLING

PART 1 - PART 1 - GENERAL

1.1 SUMMARY

- A. All labor, equipment, and materials necessary for trench excavation and trench backfill pipelines, vaults, and appurtenances.
- B. All excavation shall be classified, “unclassified excavation,” or “muck excavation” or “rock excavation,” as hereafter described. All embankment shall be classified “embankment material” as hereafter described.
- C. Related Sections:
 - 1. Section 31 2300, Excavation and Fill.
 - 2. Section 31 2319, Dewatering.
 - 3. Section 31 2323.33, Flowable Fill

1.2 REFERENCES

- A. The following is a list of standards which may be referenced in this section:
 - 1. ASTM International (ASTM):
 - a. D698, Standard Test Methods for Laboratory Compaction Characteristics of Soil Using Standard Effort (12 400 ft-lbf/ft³ (600 kN-m/m³)).
 - b. D4253, Standard Test Methods for Maximum Index Density and Unit Weight of Soils Using a Vibratory Table.
 - 2. Colorado Department of Transportation (CDOT).
 - 3. Occupational Safety and Health Administration (OSHA).

1.3 SUBMITTALS

- A. Submit certification that bedding and pipe zone material meets the requirements of “Materials” of this Section.

PART 2 - PRODUCTS

2.1 MATERIALS

- A. Muck Excavation:
 - 1. When material encountered within the limits of the work is considered unsuitable by the Development Engineering Manager, such material shall be excavated below the grade shown on the drawings to a depth necessary to ensure a stable, firm foundation and refilled with one and one-half (1½) inch crushed rock uniformly graded to provide a firm foundation, and shall be backfilled per these Section 31 2300 “Excavation and Fill.”

2. Excavated materials which are considered unsuitable and any surplus of excavated material shall be disposed of by the Contractor as required in Section 02 4119 "Selective Demolition."

B. Bedding and Pipe Zone Materials:

1. Well-Graded Sand:

Sieve Size	Total Percent Passing by Weight
3/8 - inch	100
No. 4	95 - 100
No. 8	80 - 100
No. 16	50 - 85
No. 30	25 - 60
No. 50	10 - 30
No. 100	2 - 10

2. Squeegee Sand:

Sieve Size	Total Percent Passing by Weight
3/8 - inch	100
No. 200	0 - 5

3. CDOT #67:

Sieve Size	Total Percent Passing by Weight
1 inch	100
3/4 - inch	90 - 100
3/8 - inch	20 - 55
No. 4	0 - 10
No. 8	0 - 5

- a. It shall be the responsibility of CONTRACTOR to locate material meeting the SPECIFICATIONS, to test its ability to consolidate to at least seventy- five percent (75%) relative density, and to secure approval of ENGINEER before such material is delivered to the PROJECT.
- b. Relative density shall be determined as stipulated in ASTM D4253.

C. Backfill:

1. Use only backfill for trenches which is free from rocks, large roots, other vegetation or organic matter, and frozen material.
2. No rocks greater than three (3) inches in diameter shall be allowed.
3. Backfill under roadway asphalt shall be Flowable Fill in accordance to Section 312323.33.

D. Cut-Off Walls:

1. Clay Cut-Off Walls: More than fifty percent (50%) shall pass a No. 200 Sieve. The plasticity index shall be greater than twelve (12).
2. Controlled Low Strength Material Backfill: (Flowable-Fill, See Section 312323, Flowable Fill).

E. Structural Backfill

1. When specified on the Drawings or as required by Engineer, Class I structural backfill shall meet the following gradation requirements:

Standard Size of Sieve	% by Weight Passing Sieves
2 ½ inch	100
2 inches	95 – 100
No. 4	30 - 60
No. 200	5 – 15
Liquid Limit	35 Maximum
Plasticity Index	6 Maximum

2. Impervious structural backfill, where shown or specified, shall consist of material having one hundred percent (100%) finer than two 92) inches in diameter and a minimum of thirty-five percent (35%) passing a No. 200 U.S. Standard Sieve.

PART 3 - EXECUTION

3.1 GENERAL

A. The following procedures shall be followed by CONTRACTOR in sequencing the WORK:

1. No more than one hundred fifty (150) feet of trench shall be left open at any time.
2. The entire trench shall be backfilled to within fifty (50) feet of the open trench upon conclusion of each day's WORK.
3. The trench shall not be backfilled until the pipe installation is found acceptable by ENGINEER.
4. Trench shall be backfilled within one hundred (100) feet of the pipe installation at all times.
5. Clean-up shall be maintained within four hundred (400) feet of the trench excavation.

B. Prior to placement in the trench, all pipes, fittings, and appurtenances shall be cleaned and examined for defects by CONTRACTOR.

1. If found defective, CONTRACTOR shall reject the defective pipe, fitting, or appurtenance.
2. CONTRACTOR shall advise ENGINEER of all defective materials.

C. Surplus Excavation:

1. All surplus excavation shall be placed, in an orderly manner.

2. If material is stockpiled on private property, written permission shall be obtained from the property owner and provided to ENGINEER.

3.2 OBSTRUCTIONS AND DISPOSAL OF WASTE MATERIAL

- A. CONTRACTOR shall remove obstructions that do not require replacement from within the trench or adjacent areas such as tree roots, stumps, abandoned piling, buildings and concrete structures, frozen material, logs, and debris of all types without additional compensation.
- B. ENGINEER may, if requested, make changes in the trench alignment to avoid major obstructions, if such alignment changes can be made within the WORK limits without adversely affecting the intended function of the facility.
- C. Excavated materials unsuitable for backfill or not required for backfill shall be disposed of in accordance with local regulations.

3.3 TRENCH EXCAVATION

- A. All existing asphalt or concrete surfacing shall be saw cut vertically in a straight line, and removed from the job site prior to starting the trench excavation. This material shall not be used in any fill or backfill.
- B. Clearance:
 1. The trench shall be excavated so that a minimum clearance of six (6) inches is maintained on each side of the pipe for proper placement and densification of the bedding or backfill material.
 2. The maximum clearance measured at the spring line of the pipe shall be eighteen (18) inches regardless of the type of pipe, type of soil, depth of excavation, or the method of densifying the bedding and backfill.
- C. Except as otherwise dictated by construction conditions, the excavation shall be of such dimensions as to allow for the proper pipe installation and to permit the construction of the necessary pipe connections.
- D. Care shall be taken to ensure that the excavation does not extend below established grades.
 1. If the excavation is made below such grades, the excess excavation shall be filled in with sand or graded gravel deposited in horizontal layers not more than six (6) inches in thickness after being compacted and shall be moistened as required to within two percent (2%) of the optimum moisture content required for compaction of that soil.
 2. After being conditioned to have the required moisture content, the layers shall be compacted to the required density.
- E. CONTRACTOR shall stockpile excavated materials in a safe manner. Stockpiles shall be graded for proper drainage.
- F. CONTRACTOR shall place and grade the trench base to the proper grade ahead of pipe laying. The invert of the trench shall be compacted to provide a firm unyielding support along entire pipe length.

- G. Surplus excavation shall be disposed of by CONTRACTOR at CONTRACTOR's expense.

3.4 PROTECTION

A. Sheeting and Shoring:

1. CONTRACTOR shall protect excavations by shoring, bracing, sheet piling, underpinning, or other methods required to prevent any excessive widening or sloughing of the trench which may be detrimental to human safety, to the pipe or appurtenances being installed, or to existing facilities or structures.
2. The latest requirements of OSHA shall be complied with at all times including trenching and confined space entry requirements.
3. CONTRACTOR shall be responsible for underpinning adjacent structures which may be damaged by excavation WORK, including service utilities and pipe chases.

B. Weather and Frost:

1. CONTRACTOR shall protect bottom of excavations and soil adjacent to and beneath foundations from frost.
2. Do not place backfill, fill, or embankment on frozen surfaces.
3. Do not place frozen materials, snow, or ice in backfill, fill, or embankments.
4. Do not deposit, tamp, roll, or otherwise mechanically compact backfill in water.

C. Drainage and Groundwater:

1. The excavation shall be graded to prevent surface water runoff into trench or excavation.
2. Maintain excavations and trenches free from water during construction.
3. Remove water encountered in trenches to the extent necessary to provide a firm subgrade, to permit joints to be made in the dry, and to prevent the entrance of water into the pipeline.
4. Divert surface runoff and use sumps, gravel blankets, well points, drain lines, or other means necessary to accomplish the above.
5. Maintain the excavation or trench free from water until the structure, or pipe to be installed therein, is completed to the extent that no damage from hydrostatic pressure, flotation, or other cause will result.
6. Prevent water from entering into previously constructed pipe.
7. Do not use the pipe under construction for dewatering.

3.5 FOUNDATIONS ON UNSTABLE SOILS

- A. If the bottom of the excavation is soft or unstable, and in the opinion of ENGINEER, cannot satisfactorily support the pipe or structure, a further depth and width shall be excavated and refilled to six (6) inches below grade with rock or other approved material, uniformly graded between three-quarter (3/4) inch and one and one-half (1-1/2) inches to provide a firm foundation for the pipe or structure. From six (6) inches

below grade to grade, the appropriate bedding material shall be placed to provide support for the pipe or structure.

3.6 PIPE BEDDING

- A. After completion of the trench excavation and proper preparation of the foundation, six (6) inches of bedding material shall be placed on the trench bottom for support under the pipe.
- B. Bell holes shall be dug deep enough to provide a minimum of two (2) inches of clearance between the bell and the bedding material.
- C. All pipes shall be installed in such a manner as to ensure full support of the pipe barrel over its entire length.
- D. After the pipe is adjusted for line and grade and the joint is made, the bedding material shall be carefully placed and tamped under the haunches of the pipe.
- E. For all types of pipe, the limits of bedding shall be as shown on the trench section details on the DRAWINGS.
- F. Bedding shall be compacted to seventy five percent (75%) relative density in accordance with ASTM D4253. Care shall be exercised to ensure sufficient tamping under the pipe to achieve uniform support.

3.7 BACKFILL AND COMPACTION

- A. All muck excavation, bedding, and pipe zone material shall be imported unless otherwise designated by OWNER's geotechnical engineer.
- B. Pipe:
 - 1. The pipe trench shall be backfilled to the limits as shown on the DRAWINGS.
 - 2. Where the backfill area is under roadway asphalt paving, Flowable Fill shall be installed in accordance with Section 31 2323.33.
 - 3. The backfill in all areas shall be compacted by vibrating, tamping, or a combination thereof to seventy five percent (75%) relative density for sand material as determined by the relative density of cohesionless soils test, ASTM D4253, or to ninety five percent (95%) of the Maximum Standard Proctor Density for cohesive soils as determined by ASTM D698.
 - 4. All backfill shall be brought up to equal height along each side of the pipe in such a manner as to avoid displacement.
 - 5. Bedding shall be distributed in 6-inch (6") maximum lifts over the full width of the trench.
 - 6. Wet, soft or frozen material, asphalt chunks, or other deleterious substances shall not be used for backfill.
 - 7. If the excavated material is not suitable for backfill, as determined by ENGINEER, suitable material shall be hauled in and utilized and the rejected material hauled away and disposed of.

8. Backfilling shall be conducted at all times in a manner to prevent damage to the pipe or its coating and shall be kept as close to the pipe laying operation as practical.
 9. Backfilling procedures shall conform to the additional requirements, if any, of appropriate agencies or private right-of-way agreements.
- C. Unsurfaced Areas: All surface cuts shall be, as a minimum, restored to a condition equal to that prior to construction.
- D. Surfaced Areas:
1. All surface cuts shall be, as a minimum, restored to a condition equal to that prior to construction.
 2. All gravel or paved streets shall be restored in accordance with the regulations and requirements of the agency having control or jurisdiction over the street, roadway, or right-of-way.
- E. Grassed or Landscaped Areas:
1. In landscaped or agricultural areas, topsoil, to a depth of twelve (12) inches, shall be removed from the area of general disturbance and stockpiled.
 2. After installation of all pipelines, appurtenances and structures and completion of all backfill and compaction, the stockpiled topsoil shall be redistributed evenly over all disturbed areas.
 3. Care should be taken to conform to the original ground contour or final grading plans.

3.8 FIELD QUALITY CONTROL

- A. In-place moisture density tests will be performed to ensure trench backfill complies with specified requirements. The following minimum tests will be performed.
1. Trench Bedding: One per two hundred (1 per 200) feet.
 2. Backfill: One per two hundred (1 per 200) feet.
- B. Backfill Compaction Tests:
1. Backfill compaction tests will be performed until compaction meets or exceeds requirements.
 2. The cost of "passing" tests will be paid by OWNER.
 3. Costs associated with "failing" tests shall be paid by CONTRACTOR.
- C. Pipe bedding will be tested prior to placement of backfill.
- D. Testing of all bedding and backfill material will be done in compliance with Occupational Safety & Health Administration (OSHA) - Excavations.

3.9 RESTORATION

- A. Scarify surface, reshape, and compact to required density completed or partially completed areas of WORK disturbed by subsequent construction operations or by adverse weather.

- B. Maintain and correct backfill, fill, and embankment settlement and make necessary repairs to pavement structures, seeding, and sodding which may be damaged as a result of settlement for the guarantee period.
- C. Such maintenance and correction may be performed by subcontract.
- D. Upon completion of the WORK, all plants, rubbish, unused materials, concrete forms, and other like material shall be removed from the job site.
- E. The site shall be left in a state of order and cleanliness.

END OF SECTION 31 2333

SECTION 31 2500 - EROSION AND SEDIMENTATION CONTROLS

PART 1 - GENERAL

1.1 SUMMARY

A. Section Includes:

1. Vehicle tracking pad.
2. Sediment control log.
3. On-land silt fence.
4. Concrete washout area

B. Related Requirements:

1. Section 02 4119 "Selective Demolition"
2. Section 31 2000 "Excavation and Fill."
3. Section 31 2319 "Dewatering"
4. Section 31 2323.33 "Flowable Fill."
5. Section 32 1313 "Trenching and Backfilling."

1.2 SUBMITTALS

- A. Product Data: Submit data on on-land silt fence, filter socks, erosion control blanket, baled hay erosion checks, and soil stabilization fabric.
- B. Copy of EPA NPDES Notice of Intent to Discharge submitted to the EPA as specified in QUALITY ASSURANCE Article.
- C. Submit name and applicable experience of soil erosion and sediment control manager according to Section 1.5 F.
- D. Submit Proposed Protection Measures as required in & Section 02 4119 "Selective Demolition."

1.3 QUALITY ASSURANCE

- A. Perform Work according to City of Thornton Standards and Specifications.
- B. Progress Schedule:
1. Clearly outline intended maintenance of traffic, locations where temporary and permanent soil erosion and sediment control measures will be installed, and such other information as required.
 2. Incorporate appropriate staging and seasonal constraints to maximize the effectiveness of the soil erosion and sediment controls.
- C. Soil Erosion and Sediment Control Manager:
1. Assign to the Project a supervisory-level employee to serve in the capacity of soil erosion and sediment control manager. This employee is required to be thoroughly experienced in all aspects of soil erosion and sediment control and construction. Submit the name and experience of this employee to the Engineer

for approval at least 10 working days prior to commencing any Work on the Project.

2. Assigned manager will be responsible for the following:
 - a. Implement approved soil erosion and sediment control schedules and methods of operations.
 - b. Coordinate operations with the Engineer and oversee and supervise all aspects of soil erosion and sediment control Work for the Project.
 - c. Attend all soil erosion and sediment control meetings during the Contract.

PART 2 - PRODUCTS

2.1 PERFORMANCE REQUIREMENTS

- A. Perform Work according to:
 1. The City of Thornton Standards and Specifications Detail 400-7.

2.2 VEHICLE TRACKING PAD

- A. Stone Size: 2 to 3 inches containing less than 10% fines.
- B. Length: As effective, but not less than **50 feet**.
- C. Width: Not less than full width of all points on ingress or egress, minimum 12 feet wide.
- D. Geotextile Fabric shall comply with CDOT 715.08b.
- E. Washing: When necessary, clean wheels to remove sediment prior to entrance onto public right-of-way. When washing is required, provide an area stabilized with crushed stone that drains into an approved sediment trap or sediment basin. Prevent all sediment from entering any storm drain, ditch, or watercourse by using sandbags, gravel boards, or other approved methods.
- F. Maintenance: Maintain entrance in a condition that will prevent tracking or flowing of sediment onto public rights-of-way. This may require periodic top dressing with additional stone as conditions demand and repair or cleanout of any measures used to trap sediment. Stone should be bladed and/or additional 2"-3" stone should be placed if voids begin filling with debris. All sediment spoiled, dropped, washed, or tracked onto public rights-of-way must be removed immediately.

2.3 SEDIMENT CONTROL LOG

- A. Perform Work according to:
 1. The City of Thornton Standards and Specifications Detail 400-9.
- B. Stakes shall be 1.5" x 1.5" x 24" minimum and embedded into ground a minimum of 12".
- C. Sediment control log shall be trenched 2" into ground.
- D. Sediment shall be cleaned/removed when sediment depth is ½ the height of the sediment control log.

2.4 ON-LAND SILT FENCE

- A. Perform Work according to:

1. The City of Thornton Standards and Specifications Detail 400-08.
- B. Geotextile fabric shall comply with CDOT 712.08b and extend a minimum of 6" below grade and another 6" horizontally in a "L" shape before backfilling and compacting the trench. (Slicing method is also accepted).
- C. Clean and remove silt when the silt reaches ½ the height of the geotextile fabric.
- D. Upon permanent stabilization of areas upslope of the silt fence, the silt fence shall be removed and disturbed areas permanently stabilized.

2.5 CONCRETE WASHOUT AREA DETAIL

- A. Perform Work according to:
 1. The City of Thornton Standards and Specifications Detail 400-6.
 - B. Concrete washout area to be installed prior to any concrete placement on site; placed a minimum 50' from state waters.
 - C. A plastic sheeting or geomembrane liner shall be placed. Minimum 10-mil thickness:
 - D. Waste material from concrete washout operations must be removed and legally disposed of when it has accumulated two-thirds of the wet storage capacity of the structure and at the end of construction.
 - E. When the concrete washout area is removed, the disturbed area shall be seeded and mulched or otherwise stabilized in a manner accepted by the City.

PART 3 - EXECUTION

3.1 EXAMINATION

- A. Examine substrates, areas, and conditions, with Applicator present, for compliance with requirements for maximum moisture content, installation tolerances and other conditions affecting performance of the Work.
- B. Verify compacted subgrade is acceptable and ready to support devices and imposed loads.
- C. Verify gradients and elevations of base or foundation for other Work are correct.

3.2 PROJECT REQUIREMENTS

- A. The Contractor is responsible for the timely installation and maintenance of all sedimentation control and dewatering devices necessary to prevent the movement of sediment from the construction Site to off-site areas or into wetlands or other drainage systems. Measures listed here, in addition to those shown on the Drawings, necessary to prevent the movement of sediment off-site are required to be installed, maintained, removed, and cleaned up at the expense of the Contractor. No additional charges to the Owner will be considered.

3.3 FIELD QUALITY CONTROL

- A. Inspect erosion control devices on a weekly basis and after each runoff event. Make necessary repairs to ensure erosion and sediment controls are in good working order.
- B. When tests indicate Work does not meet specified requirements, remove Work, replace, and retest.

3.4 CLEANING

- A. Do not damage structure or device during cleaning operations.
- B. Do not permit sediment to erode into construction or Site areas or natural waterways.
- C. Clean channels when depth of sediment reaches approximately one-half channel depth.

3.5 PROTECTION

- A. Immediately after placement, protect paving from premature drying, excessive hot or cold temperatures, and mechanical injury.
- B. Do not permit construction traffic over paving for seven days minimum after finishing until percent design strength of concrete has been achieved.
- C. Protect paving from elements, flowing water, or other disturbance until curing is complete.

END OF SECTION 31 2500

SECTION 32 1216 - ASPHALT PAVING

PART 1 - GENERAL

1.1 RELATED DOCUMENTS

- A. Drawings and general provisions of the Contract, including General and Supplementary Conditions and Division 01 Specification Sections, apply to this Section.
- B. Additional information concerning asphalt paving may be found on the civil drawings, and in the geotechnical engineering study. In case of conflict between the drawings, jurisdictional criteria and the information specified herein, the more stringent requirements shall govern.

1.2 SUMMARY

- A. Section Includes:
 - 1. Hot-mix asphalt paving.
 - 2. Hot-mix asphalt overlay.
 - 3. Cold milling of existing asphalt pavement.
 - 4. Hot-mix asphalt patching.
 - 5. Asphalt curbs.
 - 6. Asphalt surface treatments.
- B. Related Requirements:
 - 1. Section 02 4119 "Selective Demolition" for demolition and removal of existing asphalt pavement.
 - 2. Section 31 2300 "Excavation and Fill" for soil materials, excavating, backfilling and site grading.
- C. References:
 - 1. Colorado Department of Transportation Standard Specifications for Road and Bridge Construction, current edition and all appropriate standard special provisions.
 - 2. City of Thornton Standards and Specifications Detail 800-6.

1.3 DEFINITIONS

- A. Hot-Mix Asphalt Paving Terminology: Refer to ASTM D 8 for definitions of terms.
- B. CDOT Specifications: Colorado Department of Transportation Standard Specifications for Road and Bridge Construction, current edition and all appropriate standard special provisions.

1.4 SUBMITTALS

- A. Product Data: For each type of product indicated, include technical data and tested physical and performance properties.

- B. Hot-Mix Asphalt Designs:
 - 1. Certification, by authorities having jurisdiction, of approval of each hot-mix asphalt design proposed for the Work.
 - 2. For each hot-mix asphalt design proposed for the Work.

1.5 INFORMATIONAL SUBMITTALS

- A. Qualification Data: For paving-mix manufacturer.
- B. Material Certificates: Mixes containing recycled materials shall perform equal to mixes produced from all new materials.
 - 1. Aggregates.
 - 2. Asphalt binder.
 - 3. Asphalt cement.
 - 4. Cutback prime coat.
 - 5. Emulsified asphalt prime coat.
 - 6. Tack coat.
 - 7. Fog seal.
 - 8. Undersealing asphalt.
- C. Field quality-control reports.

1.6 QUALITY ASSURANCE

- A. Manufacturer Qualifications: A paving-mix manufacturer registered with and approved by authorities having jurisdiction or the DOT of state in which Project is located.
- B. Installer Qualifications: Engage an experienced installer who has completed hot-mix asphalt paving similar in material, design, and extend to that indicated for this Project and with a record of successful in-service performance.
- C. Testing Agency Qualifications: Qualified in accordance with ASTM D3666 for testing indicated.
- D. Regulatory Requirements: Comply with materials, workmanship, and other applicable requirements of CDOT Specifications of State of Colorado for asphalt paving work.
 - 1. Measurement and payment provisions and safety program submittals included in standard specifications do not apply to this Section.
- E. Preconstruction Conference: Conduct conference at Project site as directed by Owner's Representative.

1.7 FIELD CONDITIONS

- A. Environmental Limitations: Do not apply asphalt materials if subgrade is wet or excessively damp, if rain is imminent or expected before time required for adequate cure, or if the following conditions are not met:
 - 1. Prime Coat: Minimum surface temperature of 60 deg F.

2. Tack Coat: Minimum surface temperature of 60 deg F.
3. Slurry Coat: Comply with weather limitations in ASTM D3910.
4. Asphalt Base Course : Minimum surface temperature of 40 deg F and rising at time of placement.
5. Asphalt Surface Course: Minimum surface temperature of 60 deg F at time of placement.

PART 2 - PRODUCTS

2.1 AGGREGATES

- A. General: Use materials and gradations that have performed satisfactorily in previous installations meeting the requirements of the CDOT Specifications.
- B. Coarse Aggregate: AASHTO M 80, Class A, except that the percentage of wear shall not exceed 45 when tested per AASHTO T 96, sound; angular crushed stone, crushed gravel, or cured, crushed blast-furnace slag conforming to the requirements of Subsection 703.04 of the CDOT Specifications and Grading SX and S (Table 703-4).,
- C. Fine Aggregate: AASHTO M 6, Class A. The minimum sand equivalent, as tested per Colorado Procedure 37 shall be 80 unless otherwise specified. The fineness modulus, as determined by AASHTO T 27, shall not be less than 2.50 or greater than 3.50 unless otherwise approved. Sharp-edged natural sand or sand prepared from stone, gravel, cured blast-furnace slag, or combinations thereof.
 1. For hot-mix asphalt, limit natural sand to a maximum of 20 percent by weight of the total aggregate mass.
- D. Mineral Filler: AASHTO M 17, rock or slag dust, hydraulic cement, or other inert material. Mineral filler shall be graded within the limits of Subsection 703.06 of the CDOT Specifications and Mineral Filler Gradation (Table 703-8).

2.2 ASPHALT MATERIALS

- A. Asphalt Binder: AASHTO M 320 binder designation PG 64-22, conforming to the requirements of Subsection 702.01 of the CDOT Specifications.
- B. Asphalt Cement: AASHTO M 320 binder designation PG 64-22, conforming to the requirements of Subsection 702 of the CDOT Specifications.
- C. Emulsified Asphalt Prime Coat: AASHTO M 140 emulsified asphalt, or AASHTO M 208 cationic emulsified asphalt, slow setting, diluted in water, of suitable grade and consistency for application.
- D. Tack Coat: AASHTO M 140 emulsified asphalt, or AASHTO M 208 cationic emulsified asphalt, slow setting, diluted in water, of suitable grade and consistency for application.
- E. Fog Seal: AASHTO M 140 emulsified asphalt, or AASHTO M 208 cationic emulsified asphalt, slow setting, factory diluted in water, of suitable grade and consistency for application.
- F. Water: Potable.
- G. Undersealing Asphalt: ASTM D3141/D3141M; pumping consistency.

2.3 AUXILIARY MATERIALS

- A. Recycled Materials for Hot-Mix Asphalt Mixes: Reclaimed asphalt pavement; reclaimed, unbound-aggregate base material; and recycled asphalt shingles or glass from sources and gradations that have performed satisfactorily in previous installations, equal to performance of required hot-mix asphalt paving produced from all new materials.
- B. Herbicide: Commercial chemical for weed control, registered by the EPA, and not classified as "restricted use" for locations and conditions of application. Provide in granular, liquid, or wettable powder form.
- C. ASTM D1073 Paving Geotextile: AASHTO M 288 paving fabric; nonwoven polypropylene; resistant to chemical attack, rot, and mildew; and specifically designed for paving applications.
- D. Joint Sealant: ASTM D6690, Type II or III, hot-applied, single-component, polymer-modified bituminous sealant.

2.4 MIXES

- A. Hot-Mix Asphalt: Dense-graded, hot-laid, hot-mix asphalt plant mixes approved by authorities having jurisdiction. Furnish job-mix formulas for each pavement type, conforming to the requirements of Subsection 401.02 of the CDOT Specifications. Mix aggregates and bituminous materials in accordance with the requirements of Subsection 401.15 of the CDOT Specifications. Use approved job-mix formulas. Mix to comply with the following requirements:
 - 1. Provide mixes with a history of satisfactory performance in geographical area where Project is located.
 - 2. Base Course: Grading S.
 - 3. Surface Course: Grading SX.
- B. Emulsified-Asphalt Slurry: ASTM D3910,.

PART 3 - EXECUTION

3.1 EXAMINATION

- A. Verify that subgrade is dry and in suitable condition to begin paving.
- B. Proceed with paving only after unsatisfactory conditions have been corrected.

3.2 PREPARATION

- A. Protection: Provide protective materials, procedures, and worker training to prevent asphalt materials from spilling, coating, or building up on curbs, driveway aprons, manholes, and other surfaces adjacent to the Work.
- B. Proof-roll subgrade below pavements with heavy pneumatic-tired equipment to identify soft pockets and areas of excess yielding. Scarify, regrade and recompact surface of subgrade that is pumping or deforming as required to provide true levels, uniform slopes, and proper total thickness of paving as required in Section 31 2300 "Excavation and Fill." Do not proof-roll wet or saturated subgrades.
 - 1. Completely proof-roll subgrade in one direction. Limit vehicle speed to 3 mph.

2. Proof-roll with a loaded 10-wheel, tandem-axle dump truck weighing not less than 15 tons.
3. Excavate soft spots, unsatisfactory soils, and areas of excessive pumping or rutting, as determined by Engineer, and replace with compacted backfill or fill as directed.

3.3 COLD MILLING

- A. Clean existing pavement surface of loose and deleterious material immediately before cold milling. Remove existing asphalt pavement by cold milling to grades and cross sections indicated.
 1. Mill to a depth of one-fourth (1/4) inch plus or minus one-eighth (1/8) inch.
 2. Mill to a uniform finished surface free of excessive gouges, grooves, and ridges.
 3. Control rate of milling to prevent tearing of existing asphalt course.
 4. Repair or replace curbs, driveway aprons, manholes, and other construction damaged during cold milling.
 5. Excavate and trim unbound-aggregate base course, if encountered, and keep material separate from milled hot-mix asphalt.
 6. Patch surface depressions deeper than 1 inch after milling, before wearing course is laid.
 7. Keep milled pavement surface free of loose material and dust.
 8. Do not allow milled materials to accumulate on-site.

3.4 PATCHING

- A. Asphalt Pavement: Saw cut perimeter of patch and excavate existing pavement section to sound base. Excavate rectangular or trapezoidal patches, extending 12 inches into perimeter of adjacent sound pavement, unless otherwise indicated. Cut excavation faces vertically. Remove excavated material. Recompact existing unbound-aggregate base course to form new subgrade.
- B. Portland Cement Concrete Pavement: Break cracked slabs and roll as required to reseat concrete pieces firmly.
 1. Undersealing: Pump hot undersealing asphalt under rocking slab until slab is stabilized or, if necessary, crack slab into pieces and roll to reseat pieces firmly.
 2. Remove disintegrated or badly cracked pavement. Excavate rectangular or trapezoidal patches, extending into perimeter of adjacent sound pavement, unless otherwise indicated. Cut excavation faces vertically. Recompact existing unbound-aggregate base course to form new subgrade.
- C. Tack Coat: Before placing patch material, apply tack coat uniformly to vertical asphalt surfaces abutting the patch. Apply at a rate of 0.05 to 0.15 gal./sq. yd.
 1. Allow tack coat to cure undisturbed before applying hot-mix asphalt paving.
 2. Avoid smearing or staining adjoining surfaces, appurtenances, and surroundings. Remove spillages and clean affected surfaces.

- D. Placing Single-Course Patch Material: Fill excavated pavement areas with hot-mix asphalt base mix for full thickness of patch and, while still hot, compact flush with adjacent surface.
- E. Placing Two-Course Patch Material: Partially fill excavated pavements with hot-mix asphalt base course mix and, while still hot, compact. Cover asphalt base course with compacted layer of hot-mix asphalt surface course, finished flush with adjacent surfaces.

3.5 REPAIRS

- A. Leveling Course: Install and compact leveling course consisting of hot-mix asphalt surface course to level sags and fill depressions deeper than 1 inch in existing pavements.
 - 1. Install leveling wedges in compacted lifts not exceeding 3 inches thick.
- B. Crack and Joint Filling: Remove existing joint filler material from cracks or joints to a depth of approximately twice the crack width.
 - 1. Clean cracks and joints in existing hot-mix asphalt pavement.
 - 2. Use emulsified-asphalt slurry to seal cracks and joints less than 1/4 inch wide. Fill flush with surface of existing pavement and remove excess.
 - 3. Use hot-applied joint sealant to seal cracks and joints more than 1/4 inch wide. Fill flush with surface of existing pavement and remove excess.

3.6 SURFACE PREPARATION

- A. Ensure that prepared subgrade has been proof-rolled and is ready to receive paving. Immediately before placing asphalt materials, remove loose and deleterious material from substrate surfaces.
- B. Herbicide Treatment: Apply herbicide in accordance with manufacturer's recommended rates and written application instructions. Apply to dry, prepared subgrade or surface of compacted-aggregate base before applying paving materials.
 - 1. Mix herbicide with prime coat if formulated by manufacturer for that purpose.
- C. Cutback Prime Coat: Apply uniformly over surface of compacted unbound-aggregate base course at a rate of 0.15 to 0.50 gal./sq. yd. Apply enough material to penetrate and seal, but not flood, surface. Allow prime coat to cure.
 - 1. If prime coat is not entirely absorbed within 24 hours after application, spread sand over surface to blot excess asphalt. Use enough sand to prevent pickup under traffic. Remove loose sand by sweeping before pavement is placed and after volatiles have evaporated.
 - 2. Protect primed substrate from damage until ready to receive paving.
- D. Emulsified Asphalt Prime Coat: Apply uniformly over surface of compacted unbound-aggregate base course at a rate of 0.10 to 0.30 gal./sq. yd. per inch depth. Apply enough material to penetrate and seal, but not flood, surface. Allow prime coat to cure.
 - 1. If prime coat is not entirely absorbed within 24 hours after application, spread sand over surface to blot excess asphalt. Use enough sand to prevent pickup

under traffic. Remove loose sand by sweeping before pavement is placed and after volatiles have evaporated.

2. Protect primed substrate from damage until ready to receive paving.
- E. Tack Coat: Apply uniformly to surfaces of existing pavement at a rate of 0.05 to 0.15 gal./sq. yd..
1. Allow tack coat to cure undisturbed before applying hot-mix asphalt paving.
 2. Avoid smearing or staining adjoining surfaces, appurtenances, and surroundings. Remove spillages and clean affected surfaces.

3.7 HOT-MIX ASPHALT PLACEMENT

- A. Machine place hot-mix asphalt on prepared surface, spread uniformly, and strike off. Place asphalt mix by hand in areas inaccessible to equipment in a manner that prevents segregation of mix. Place each course to required grade, cross section, and thickness when compacted.
1. Place hot-mix asphalt base course and binder course in number of lifts and thicknesses indicated.
 2. Place hot-mix asphalt surface course in single lift.
 3. Spread mix at a minimum temperature of 250 deg F.
 4. Begin applying mix along centerline of crown for crowned sections and on high side of one-way slopes unless otherwise indicated.
 5. Regulate paver machine speed to obtain smooth, continuous surface free of pulls and tears in asphalt-paving mat.
- B. Place paving in consecutive strips not less than 10 feet wide unless infill edge strips of a lesser width are required.
1. After first strip has been placed and rolled, place succeeding strips and extend rolling to overlap previous strips. Overlap mix placement about 1 to 1-1/2 inches from strip to strip to ensure proper compaction of mix along longitudinal joints.
 2. Complete a section of asphalt base course and binder course before placing asphalt surface course.
- C. Promptly correct surface irregularities in paving course behind paver. Use suitable hand tools to remove excess material forming high spots. Fill depressions with hot-mix asphalt to prevent segregation of mix; use suitable hand tools to smooth surface.

3.8 JOINTS

- A. Construct joints to ensure a continuous bond between adjoining paving sections. Construct joints free of depressions, with same texture and smoothness as other sections of hot-mix asphalt course.
1. Clean contact surfaces and apply tack coat to joints.
 2. Offset longitudinal joints, in successive courses, a minimum of 6 inches.
 3. Offset transverse joints, in successive courses, a minimum of 24 inches.

4. Construct transverse joints at each point where paver ends a day's work and resumes work at a subsequent time. Construct these joints using either "bulkhead" or "papered" method in accordance with AI MS-22, for both "Ending a Lane" and "Resumption of Paving Operations."
5. Compact joints as soon as hot-mix asphalt will bear roller weight without excessive displacement.
6. Compact asphalt at joints to a density within 2 percent of specified course density.

3.9 COMPACTION

- A. General: Begin compaction as soon as placed hot-mix paving will bear roller weight without excessive displacement. Compact hot-mix paving with hot hand tampers or with vibratory-plate compactors in areas inaccessible to rollers.
 1. Complete compaction before mix temperature cools to 185 deg F.
- B. Breakdown Rolling: Complete breakdown or initial rolling immediately after rolling joints and outside edge. Examine surface immediately after breakdown rolling for indicated crown, grade, and smoothness. Correct laydown and rolling operations to comply with requirements.
- C. Intermediate Rolling: Begin intermediate rolling immediately after breakdown rolling while hot-mix asphalt is still hot enough to achieve specified density. Continue rolling until hot-mix asphalt course has been uniformly compacted to the following density in accordance with Subsection 401.17 of the CDOT Specifications:
 1. Pavement shall be compacted to a density of 92% to 96% of the maximum theoretical density, determined according to Colorado Procedure 51. Field density determination will be in accordance with Colorado Procedure 44 or 81.
- D. Finish Rolling: Finish roll paved surfaces to remove roller marks while hot-mix asphalt is still warm.
- E. Edge Shaping: While surface is being compacted and finished, trim edges of pavement to proper alignment. Bevel edges while asphalt is still hot; compact thoroughly.
- F. Repairs: Remove paved areas that are defective or contaminated with foreign materials and replace with fresh, hot-mix asphalt. Compact by rolling to specified density and surface smoothness.
- G. Protection: After final rolling, do not permit vehicular traffic on pavement until it has cooled and hardened.
- H. Erect barricades to protect paving from traffic until mixture has cooled enough not to become marked.

3.10 ASPHALT CURBS

- A. Construct hot-mix asphalt curbs over compacted pavement surfaces. Apply a light tack coat unless pavement surface is still tacky and free from dust. Spread hot-mix asphalt at a minimum temperature of 250 deg F.
 1. Hot-Mix Asphalt: Same as pavement surface-course mix.

- B. Place hot-mix asphalt to curb cross section indicated or, if not indicated, to local standard shapes, by machine or by hand in wood or metal forms. Tamp hand-placed materials and screed to smooth finish. Remove forms after hot-mix asphalt has cooled.

3.11 INSTALLATION TOLERANCES

- A. Pavement Thickness: Compact each course to produce thickness indicated within the following tolerances:
 - 1. Base Course : Plus or minus 1/4 inch.
 - 2. Surface Course: Plus 1/4 inch, no minus.
- B. Pavement Surface Smoothness: Compact each course to produce surface smoothness within the following tolerances as determined by using a 10-foot straightedge applied transversely or longitudinally to paved areas:
 - 1. Base Course : 1/4 inch.
 - 2. Surface Course: 3/16 inch (5 mm).
 - 3. Crowned Surfaces: Test with crowned template centered and at right angle to crown. Maximum allowable variance from template is 1/4 inch.
- C. Asphalt Traffic-Calming Devices: Compact and form asphalt to the shapes indicated and within a tolerance of plus or minus 1/8 inch of height indicated above pavement surface.

3.12 SURFACE TREATMENTS

- A. Fog Seals: Apply fog seal at a rate of 0.10 to 0.15 gal./sq. yd. to existing asphalt pavement and allow to cure. With fine sand, lightly dust areas receiving excess fog seal.
- B. Slurry Seals: Apply slurry coat in a uniform thickness in accordance with ASTM D3910 and allow to cure.
 - 1. Roll slurry seal to remove ridges and provide a uniform, smooth surface.

3.13 FIELD QUALITY CONTROL

- A. Testing Agency: Engage a qualified testing agency to perform tests and inspections.
- B. Thickness: In-place compacted thickness of hot-mix asphalt courses will be determined in accordance with ASTM D3549/D3549M.
- C. Surface Smoothness: Finished surface of each hot-mix asphalt course will be tested for compliance with smoothness tolerances.
- D. In-Place Density: Testing agency will take samples of uncompacted paving mixtures and compacted pavement in accordance with ASTM D3549.
 - 1. Reference maximum theoretical density will be determined by averaging results from four samples of hot-mix asphalt-paving mixture delivered daily to site, prepared in accordance with ASTM D2041/D2041M, and compacted in accordance with job-mix specifications.
 - 2. In-place density of compacted pavement will be determined by testing core samples in accordance with ASTM D1188 or ASTM D2726/D2726M.

- a. One core sample will be taken for every 1000 sq. yd. or less of installed pavement, with no fewer than three cores taken.
 - b. Field density of in-place compacted pavement may also be determined by nuclear method in accordance with ASTM D2950/D2950M and coordinated with ASTM D1188 or ASTM D2726/D2726M.
- E. Replace and compact hot-mix asphalt where core tests were taken.
- F. Remove and replace or install additional hot-mix asphalt where test results or measurements indicate that it does not comply with specified requirements.

END OF SECTION 32 1216

SECTION 32 9200 - SEEDING

PART 1 - GENERAL

1.1 SUMMARY

A. Section includes:

1. Seeding

1.2 SUBMITTALS

A. Proposed seed mix composition.

1.3 DELIVERY, STORAGE, AND HANDLING

A. Seed and Other Packaged Materials: Deliver packaged materials in original, unopened containers.

B. Bulk Materials:

1. Do not dump or store bulk materials near structures, utilities, walkways and pavements, or on existing turf areas or plants.
2. Provide erosion-control measures to prevent erosion or displacement of bulk materials..

PART 2 - PRODUCTS

2.1 SEED

A. Native Seed Mixes:

1. Thornton Buff/Blue Grama Mix
2. City-approved seed mix alternate.

2.2 FERTILIZERS

A. Native grass seeding: broadcast 1500 lbs/acre Biosol Forte Mix 7-2-3, or approved equal, before seeding.

2.3 MULCHES

A. Straw or mulch the seed to hold in place after seeding.

PART 3 - EXECUTION

3.1 EXAMINATION

A. Examine areas to be planted for compliance with requirements and other conditions affecting installation and performance of the Work.

1. Verify that no foreign or deleterious material or liquid such as paint, paint washout, concrete slurry, concrete layers or chunks, cement, plaster, oils, gasoline, diesel fuel, paint thinner, turpentine, tar, roofing compound, or acid has been deposited in soil within a planting area.
2. Suspend planting operations during periods of excessive soil moisture until the moisture content reaches acceptable levels to attain the required results.

3. Uniformly moisten excessively dry soil that is not workable or which is dusty.

B. Proceed with installation only after unsatisfactory conditions have been corrected.

3.2 PREPARATION

A. Install erosion-control measures to prevent erosion or displacement of soils and discharge of soil-bearing water runoff or airborne dust to adjacent properties and walkways.

3.3 SEEDING

A. The seedbed shall be free of debris including weeds, plant matter, rocks, clods, and other impervious material over one (1) inch in diameter. Seedbed shall be smooth and free of large clumps, fluffy yet firm, moist but not wet.

B. Seeding shall be done immediately after soil preparation operations to discourage weed competition. Seed shall be evenly distributed over fertilized ground on a still day into a slightly moist seedbed, using an approved grass drill followed by packer wheels. Hand-broadcasting methods shall be at double the seeding rate and shall be 'raked in' or otherwise covered with soil to a depth of ¼ inch. Hydraulic seeding can be used in areas not accessible for machine methods; seed and mulch shall not be applied in the same operation.

C. Within 12 hours of seeding, water seeded area frequently and lightly. Water enough to keep the soil moist, but not so heavily as to cause soil washing and loss of the grass seed.

3.4 ESTABLISHMENT TIME AND ACCEPTANCE

A. Seeded areas will not be accepted until the stand of grass displays uniform coverage of the seed mix planted, with all species of the mix being well represented, and minimal weeds are present, as determined by the City.

END OF SECTION 32 9200

SECTION 33 0500 - COMMON WORK RESULTS FOR UTILITIES

PART 1 - GENERAL

1.1 SUMMARY

A. Section Includes:

1. Grout.
2. Flowable fill.
3. Piped utility demolition.
4. Piping system common requirements.
5. Equipment installation common requirements.
6. Concrete bases.

1.2 DEFINITIONS

- A. PVC: Polyvinyl chloride plastic.

1.3 DELIVERY, STORAGE, AND HANDLING

- A. Deliver pipes and tubes with factory-applied end caps. Maintain end caps through shipping, storage, and handling to prevent pipe end damage and to prevent entrance of dirt, debris, and moisture.
- B. Store plastic pipes protected from direct sunlight. Support to prevent sagging and bending.

1.4 COORDINATION

- A. Coordinate installation of required supporting devices and set sleeves in poured-in-place concrete and other structural components as they are constructed.
- B. Coordinate size and location of concrete bases.

PART 2 - PRODUCTS

2.1 GROUT

- A. Description: ASTM C1107, Grade B, nonshrink and nonmetallic, dry hydraulic-cement grout.
1. Characteristics: Post hardening, volume adjusting, nonstaining, noncorrosive, nongaseous, and recommended for interior and exterior applications.
 2. Design Mix: 5000-psi, 28-day compressive strength.
 3. Packaging: Premixed and factory packaged.

2.2 FLOWABLE FILL

- A. Description: Low-strength-concrete, flowable-slurry mix.
1. Cement: ASTM C150, Type I, portland.
 2. Density: 115- to 145-lb/cu. ft..

3. Aggregates:
 - a. ASTM C33, natural sand, fine and crushed gravel or stone, coarse.
 - b. ASTM C33, natural sand, fine.
4. Admixture: ASTM C618, fly-ash mineral.
5. Water: Comply with ASTM C94/C94M.
6. Strength: 100 to 200 psig at 28 days.

PART 3 - EXECUTION

3.1 PIPED UTILITY DEMOLITION

- A. Refer to Section 02 4119 "Selective Demolition" for general demolition requirements and procedures.
- B. Disconnect, demolish, and remove piped utility systems, equipment, and components indicated to be removed.
 1. Piping to Be Removed: Remove portion of piping indicated to be removed and cap or plug remaining piping with same or compatible piping material.
 2. Piping to Be Abandoned in Place: Drain piping. Fill abandoned piping with flowable fill, and cap or plug piping with same or compatible piping material.
 3. Equipment to Be Removed: Disconnect and cap services and remove equipment.
- C. If pipe, insulation, or equipment to remain is damaged in appearance or is unserviceable, remove damaged or unserviceable portions and replace with new products of equal capacity and quality.

3.2 INSTALLATION OF PIPING

- A. Install piping according to the following requirements and utilities Sections specifying piping systems.
- B. Drawing plans, schematics, and diagrams indicate general location and arrangement of piping systems. Indicated locations and arrangements were used to size pipe and calculate friction loss, expansion, pump sizing, and other design considerations. Install piping as indicated unless deviations to layout are approved on the Coordination Drawings.
- C. Install piping at structure penetrations perpendicular to building walls.
- D. Install piping to permit valve servicing.
- E. Install piping at indicated slopes.
- F. Install piping free of sags and bends.
- G. Install fittings for changes in direction and branch connections.
- H. Select system components with pressure rating equal to or greater than system operating pressure.
- I. Verify final equipment locations for roughing-in.

- J. Refer to equipment specifications in other Sections for roughing-in requirements.

3.3 PIPING JOINT CONSTRUCTION

- A. Join pipe and fittings according to the following requirements and utilities Sections specifying piping systems.
- B. Ream ends of pipes and tubes and remove burrs. Bevel plain ends of steel pipe.
- C. Remove scale, slag, dirt, and debris from inside and outside of pipe and fittings before assembly.
- D. Plastic Pressure Piping Gasketed Joints: Join according to ASTM D3139.

3.4 INSTALLATION OF EQUIPMENT

- A. Install equipment level and plumb, unless otherwise indicated.
- B. Install equipment to facilitate service, maintenance, and repair or replacement of components. Connect equipment for ease of disconnecting, with minimum interference with other installations. Extend grease fittings to an accessible location.
- C. Install equipment to allow right of way to piping systems installed at required slope.

3.5 CONCRETE BASES

- A. Concrete Bases: Anchor equipment to concrete base according to equipment manufacturer's written instructions and according to seismic codes at Project.
 1. Construct concrete bases of dimensions per Manufacturer's recommendations, but not less than 4 inches larger in both directions than supported unit.
 2. Install dowel rods to connect concrete base to concrete floor. Unless otherwise indicated, install dowel rods on 18-inch centers around the full perimeter of base.
 3. Install epoxy-coated anchor bolts for supported equipment that extend through concrete base, and anchor into structural concrete floor.
 4. Place and secure anchorage devices. Use supported equipment manufacturer's setting drawings, templates, diagrams, instructions, and directions furnished with items to be embedded.
 5. Install anchor bolts to elevations required for proper attachment to supported equipment.
 6. Install anchor bolts according to anchor-bolt manufacturer's written instructions.
 7. Use 3000-psi, 28-day compressive-strength concrete and reinforcement.

3.6 GROUTING

- A. Mix and install grout for equipment base bearing surfaces, equipment base plates, and anchors.
- B. Clean surfaces that will come into contact with grout.
- C. Provide forms as required for placement of grout.
- D. Avoid air entrapment during placement of grout.
- E. Place grout, completely filling equipment bases.

- F. Place grout on concrete bases and provide smooth bearing surface for equipment.
- G. Place grout around anchors.
- H. Cure placed grout.

END OF SECTION 33 0500

SECTION 33 1415 - SITE WATER DISTRIBUTION PIPING

PART 1 - GENERAL

1.1 SUMMARY

- A. Section Includes:
 - 1. PVC pipe and fittings.
 - 2. Piping joining materials.
 - 3. Piping specialties.
 - 4. Encasement for piping.
 - 5. Gate valves.
 - 6. Gate valve accessories and specialties.
 - 7. Pressure-reducing valves.

1.2 DEFINITIONS

- A. EPDM: Ethylene-propylene-diene terpolymer rubber.
- B. PE: Polyethylene plastic.

1.3 ACTION SUBMITTALS

- A. Product Data: For each type of product.
- B. Shop Drawings:
 - 1. Detail precast concrete vault assemblies and indicate dimensions, method of field assembly, and components.
 - 2. Include diagrams for power, signal, and control wiring for alarms.

1.4 INFORMATIONAL SUBMITTALS

- A. Coordination Drawings: For piping and specialties including relation to other services in same area, drawn to scale. Show piping and specialty sizes and valves, meter and specialty locations, and elevations.
- B. Field Quality-Control Submittals:
 - 1. Field quality-control reports.

1.5 CLOSEOUT SUBMITTALS

- A. Operation and Maintenance Data: For each type of product indicated.

1.6 DELIVERY, STORAGE, AND HANDLING

- A. Preparation for Transport: Prepare piping and valves according to the following:
 - 1. Ensure that piping and valves are dry and internally protected against rust and corrosion.
 - 2. Protect flange faces against damage.
 - 3. Set piping and valves in best position for handling and to prevent rattling.

- B. During Storage: Use precautions for piping and valves according to the following:
 - 1. Do not remove end protectors unless necessary for inspection; then reinstall for storage.
 - 2. Protect from weather. Store indoors and maintain temperature higher than ambient dew point temperature. Support off the ground or pavement in watertight enclosures when outdoor storage is necessary.
- C. Handling: Use sling to handle products if size requires handling by crane or lift. Rig products to avoid damage to exposed parts. Do not use handwheels or stems as lifting or rigging points.
- D. Deliver piping with factory-applied end caps. Maintain end caps through shipping, storage, and handling to prevent pipe-end damage and to prevent entrance of dirt, debris, and moisture.
- E. Protect stored piping from moisture and dirt. Elevate above grade. Do not exceed structural capacity of floor when storing inside.
- F. Protect flanges, fittings, and specialties from moisture and dirt.

PART 2 - PRODUCTS

2.1 PERFORMANCE REQUIREMENTS

- A. Comply with requirements of utility company supplying water. Include tapping of water mains.
- B. Comply with standards of authorities having jurisdiction for domestic water-service piping, including materials, installation, testing, and disinfection.
- C. Piping materials to bear label, stamp, or other markings of specified testing agency.
- D. Electrical Components, Devices, and Accessories: Listed and labeled as defined in NFPA 70, by a testing agency acceptable to authorities having jurisdiction, and marked for intended location and application.
- E. All piping and appurtenances intended to convey or dispense water for human consumption are to comply with the U.S. Safe Drinking Water Act (SDWA), with requirements of the Authority Having Jurisdiction (AHJ), and with NSF 61/NSF 372 or are certified in compliance with NSF 61/NSF 372 by an ANSI-accredited third-party certification body, that the weighted average lead content at wetted surfaces is less than or equal to 0.25 percent.

2.2 PVC PIPE

- A. PVC Pipe: AWWA C900, Class 200, with bell end with gasket, and with spigot end.
 - 1. PVC Fabricated Fittings: AWWA C900, Class 200, with bell-and-spigot or double-bell ends. Include elastomeric gasket in each bell.

2.3 MECHANICALLY RESTRAINED JOINTS

- A. Megalug, Cam-Lok or approved equal shall be used.
- B. Tie rods may be used as approved by the Engineer. If tie rods are used, they shall be mild steel, ASTM Standard Designation A-36.

- C. Hex nuts shall be ASTM Standard Designation A-307, grade A or B, Hexagon Heavy series.

2.4 FITTINGS

- A. Cast iron fittings shall be manufactured in accordance with the following AWWA standards: C-104, "Cement Mortar Lining for Ductile Iron Pipe and Fittings for Water," C-150, "Ductile Iron Fittings" and C111, "Rubber Gasket Joints for Ductile Iron Pressure for Pipe and Fittings," with the following additional requirements:
- B. Fittings shall be lined per applicable AWWA standards and manufacturer's recommendations..
- C. Fittings shall be furnished with mechanical joints with the tee-head mechanical joint bolts and hexagon nuts.
- D. Fittings shall be rated for 250 psi pressure.
- E. Corrosion protection shall be provided in accordance with Detail 200-15. In lieu of the wrap material shown, provide V-Bio or approved equal.

2.5 THRUST BLOCKS

- A. Construct concrete thrust blocks for all fittings where changes of alignment occur in accordance with the Contract Drawings.

2.6 PIPING JOINING MATERIALS

- A. Plastic Pipe-Flange Gasket, Bolts, and Nuts: Type and material recommended by piping system manufacturer unless otherwise indicated.

2.7 PIPING SPECIALTIES

- A. Transition Fittings: Manufactured fitting or coupling same size as, with pressure rating at least equal to and ends compatible with, piping to be joined.
- B. Tubular-Sleeve Pipe Couplings: Metal, bolted, sleeve-type, reducing or transition coupling, with center sleeve, gaskets, end rings, and bolt fasteners and with ends of same sizes as piping to be joined.
 - 1. Source Limitations: Obtain tubular-sleeve pipe couplings from single manufacturer.
 - 2. Standard: AWWA C219.
 - 3. Pressure Rating: 200 psig minimum.
 - 4. Metal Component Finish: Corrosion-resistant coating or material.

2.8 ENCASUREMENT FOR PIPING, VALVES, FITTINGS, AND BURIED FERROUS MATERIALS

- A. Standards: ASTM A674 or AWWA C105/A21.5.
- B. Material: Linear low-density PE film of 0.008-inch minimum thickness.

2.9 TRACER WIRE

- A. Tracer wire shall be 16 ga. minimum (HDPE Coated) Copper Tracer wire, manufactured for direct bury service.

- B. Wire shall be continuous without breaks.

2.10 GATE VALVES

- A. Gate Valves - AWWA, Cast Iron:

1. Source Limitations: Obtain gate valves - AWWA, cast iron, from single manufacturer.
2. Gate Valves - Nonrising Stem, Resilient Seated: Cast-iron body and bonnet, with bronze gate, resilient seats, and bronze stem.
 - a. Standards: AWWA C509 or AWWA C515.
 - b. Minimum Pressure Rating: 200 psig.
 - c. Refer to Contract Drawings for additional requirements.

- B. Corrosion protection shall be provided in accordance with City of Thornton Water System Standards and Specifications Detail 200-15. In lieu of the wrap material shown, provide V-Bio or approved equal.

2.11 GATE VALVE ACCESSORIES AND SPECIALTIES

- A. Valve Boxes: Comply with AWWA M44 for cast-iron valve boxes. Include top section, adjustable extension of length required for depth of burial of valve, plug with lettering "WATER," and bottom section with base that fits over valve.
- B. Indicator Posts: UL 789, FM Global approved, vertical-type, cast-iron body with operating wrench, extension rod, and adjustable cast-iron barrel of length required for depth of burial of valve.
- C. Refer to Contract Drawings for additional requirements.
- D. Corrosion protection shall be provided in accordance with City of Thornton Water System Standards and Specifications Detail 200-15. In lieu of the wrap material shown, provide V-Bio or approved equal.

2.12 BEDDING

- A. Granular Bedding Materials shall be squeegee, non-fractured, and rounded

2.13 PRESSURE-REDUCING VALVES

- A. Refer to Contract Drawings for material requirements.

PART 3 - EXECUTION

3.1 EARTHWORK

- A. Comply with excavating, trenching, and backfilling requirements in Division 31 specification sections.

3.2 PIPING APPLICATIONS

- A. Transition couplings and special fittings with pressure ratings at least equal to piping pressure rating may be used unless otherwise indicated.
- B. Do not use flanges or unions for underground piping.

- C. Flanges, unions, grooved-end-pipe couplings, and special fittings may be used, instead of joints indicated, on aboveground piping and piping in vaults.

3.3 PIPING SYSTEMS - COMMON REQUIREMENTS

- A. Comply with Section 33 0500 "Common Work Results for Utilities" for piping-system common requirements.
- B. Provide a continuous tracer wire in sufficient length over each separate run of nonmetallic pipe. Refer to the Contract Drawings for additional requirements.

3.4 INSTALLATION OF PIPING

- A. Water-Main Connection:
 - 1. Arrange with utility company for tap of size and in location indicated in water main.
 - 2. Tap water main in accordance with requirements of water utility company and of size and in location indicated.
- B. Install PVC, AWWA pipe in accordance with ASTM F645 and AWWA M23.
- C. Install underground piping with restrained joints at horizontal and vertical changes in direction. Use restrained-joint piping, thrust blocks, anchors, tie-rods and clamps, and other supports.
- D. Refer to the Contract Drawings for additional requirements.

3.5 JOINT CONSTRUCTION

- A. Comply with Section 33 0500 "Common Work Results for Utilities" for basic piping joint construction.
- B. Make pipe joints according to the following:
 - 1. PVC Piping Gasketed Joints: Use joining materials in accordance with AWWA C900. Construct joints with elastomeric seals and lubricant in accordance with ASTM D2774 or ASTM D3139 and pipe manufacturer's written instructions.

3.6 INSTALLATION OF ANCHORAGE

- A. Anchorage: Install water-distribution piping with restrained joints. Anchorages and restrained-joint types that may be used include the following:
 - 1. Concrete thrust blocks.
 - 2. Locking mechanical joints.
 - 3. Pipe clamps and tie rods.
- B. Install anchorages for plugs and caps, bends, and valves. Include anchorages for the following piping systems:
 - 1. Gasketed-Joint, PVC Water-Service Piping: In accordance with AWWA M23.
- C. Apply full coat of asphalt or other acceptable corrosion-resistant material to surfaces of installed ferrous anchorage devices.

3.7 INSTALLATION OF VALVES

- A. AWWA Gate Valves: Comply with AWWA C600 and AWWA M44. Install each underground valve with stem pointing up and with valve box.
- B. Pressure-Reducing Valves: Install in vault or aboveground between shutoff valves. Refer to Contract Drawings for additional requirements.

3.8 CONNECTIONS

- A. See Section 33 0500 "Common Work Results for Utilities" for piping connections to valves and equipment.
- B. Connect water-distribution piping to existing water main.
- C. Ground equipment in accordance with Section 26 0526 "Grounding and Bonding for Electrical Systems."
- D. Connect wiring in accordance with Section 26 0519 "Low-Voltage Electrical Power Conductors and Cables."

3.9 FIELD QUALITY CONTROL

- A. Piping Tests: Conduct piping tests before joints are covered and after concrete thrust blocks have hardened sufficiently. Fill pipeline 24 hours before testing and apply test pressure to stabilize system. Use only potable water.
- B. Hydrostatic Tests: Test at not less than one-and-one-half times working pressure for two hours.
 - 1. Increase pressure in 50 psig increments and inspect each joint between increments. Hold at test pressure for one hour; decrease to 0 psig. Slowly increase again to test pressure and hold for one more hour. Maximum allowable leakage is 2 quarts per hour per 100 joints. Remake leaking joints with new materials and repeat test until leakage is within allowed limits.
- C. Prepare reports of testing activities.
- D. Refer to City of Thornton Design and Construction standards for additional testing requirements.

3.10 IDENTIFICATION

- A. Install continuous underground warning tape during backfilling of trench for underground water-distribution piping. Locate below finished grade, directly over piping.

3.11 CLEANING

- A. Clean and disinfect water-distribution piping as follows:
 - 1. Purge new water-distribution piping systems and parts of existing systems that have been altered, extended, or repaired before use.
 - 2. Use purging and disinfecting procedure prescribed by authorities having jurisdiction or, if method is not prescribed by authorities having jurisdiction, use procedure described in NFPA 24 for flushing of piping. Flush piping system with clean, potable water until dirty water does not appear at points of outlet.

3. Precautions shall be taken to prevent foreign material from entering the pipe during installation. Debris, tools, clothing, or other materials shall not be placed in or allowed to enter the pipe. Pipe shall be capped during breaks to prevent animal entrance and trench water.
 4. Use purging and disinfecting procedure prescribed by authorities having jurisdiction or, if method is not prescribed by authorities having jurisdiction, use procedure described in AWWA C651 or do as follows:
 - a. Fill system or part of system with water/chlorine solution containing at least 50 ppm of chlorine; isolate and allow to stand for 24 hours.
 - b. Drain system or part of system of previous solution and refill with water/chlorine solution containing at least 200 ppm of chlorine; isolate and allow to stand for three hours.
 - c. After standing time, flush system with clean, potable water until no chlorine remains in water coming from system.
 - d. Submit water samples in sterile bottles to authorities having jurisdiction. Repeat procedure if biological examination shows evidence of contamination.
 5. Refer to City of Thornton Design and Construction standards for additional testing requirements.
- B. Prepare reports of purging and disinfecting activities.

END OF SECTION 33 1415

APPENDIX A
GEO TECHNICAL REPORT

GEOTECHNICAL ENGINEERING REPORT

E. 86th and Madison Ct. PRV Station Replacement
Thornton, Colorado

Prepared for:

City of Thornton

Thornton, Colorado

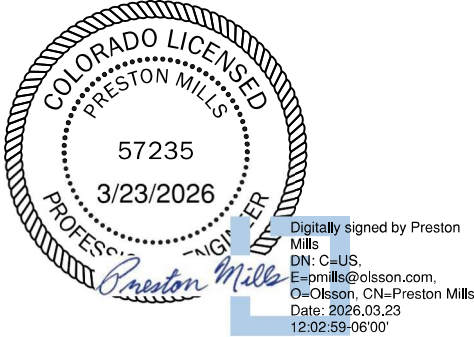

March 2026

Olsson Project No. 025-02626





March 23, 2026

City of Thornton
Attn: Mark Mazzucco
9500 Civic Center Drive
Thornton, CO 80229

RE: Geotechnical Engineering Report
East 86th and Madison Court PRV Station Replacement
Thornton, Colorado
Olsson Project No. 025-02626

Dear Mr. Mazzucco:

Olsson, Inc. has completed the authorized geotechnical exploration for the above-referenced project. The geotechnical exploration was conducted to evaluate the subsurface conditions with respect to design and construction of the project. The enclosed report summarizes the project characteristics as we understand them, presents the findings of the exploration and laboratory testing, discusses the observed subsurface conditions, and provides our geotechnical engineering recommendations.

We appreciate the opportunity to provide our geotechnical engineering services for this project and are prepared to provide construction phase services as well. If you have any questions or need further assistance, please contact us at your convenience.

Respectfully submitted,
Olsson, Inc.

A handwritten signature in blue ink that reads "Preston Mills".

Preston Mills, PE

Engineer

pmills@olsson.com

A handwritten signature in blue ink that reads "Shameem A. Dewan".

Shameem A. Dewan, PE

Senior Geotechnical Engineer

sdewan@olsson.com

TABLE OF CONTENTS

- Executive Summary 1
- 1. Project Understanding..... 2
 - 1.1 Project Information 2
 - 1.2 Site Description 2
- 2. Subsurface Conditions 4
 - 2.1 Subsurface Profile 4
 - 2.2 Water Level Observations 4
 - 2.3 Corrosivity of Soils 5
- 3. Geotechnical Considerations..... 6
- 4. Earthwork and Construction Considerations..... 7
 - 4.1 Site Preparation..... 7
 - 4.2 Structural Fill 7
 - 4.3 Dewatering Considerations..... 9
 - 4.4 Temporary Slopes and Excavations 9
 - 4.5 Equipment Mobility 9
- 5. Structures Design.....11
 - 5.1 Mat Foundations.....11
 - 5.2 Lateral Earth Pressures12
 - 5.3 Seismic Site Classification14
 - 5.4 Permanent Slopes14
- 6. Report Limitations15

LIST OF FIGURES

- Figure 1. 2023 Aerial Photograph/Project Location Plan. 3
- Figure 2. Lateral Earth Pressure Calculations.13

LIST OF TABLES

Table 1. Structural Fill Placement Guidelines.....	8
Table 2. Earth Pressure Parameters.....	12

APPENDICES

Appendix A Exploration Maps, Log, and Information

Appendix B Laboratory Test Results

EXECUTIVE SUMMARY

In February of 2026, Olsson conducted a geotechnical exploration to assess subsurface conditions and offer geotechnical recommendations for a pressure reducing valve (PRV) station, located south of the intersection of East 86th Avenue and Madison Court in Thornton, Colorado. This exploration involved drilling one geotechnical boring to a depth of 25 feet to provide subsurface insights and earthwork recommendations for the proposed structure.

Based on the findings from the geotechnical exploration, and our analyses, the site is generally suitable for the proposed construction. Surficial clayey gravel fill soils were encountered to a depth of 2 feet overlying native clays and sands. The onsite materials appear suitable for reuse as structural fill at the site.

This Executive Summary provides a limited overview of the report and is subject to any and all clarifications, conditions, contingencies, limitations and/or qualifications that may exist in the body of the report. The Client nor any other party may rely solely on this Executive Summary. Client and any other party using this report must review the entire report and interpret the information contained in this Executive Summary in conjunction with the remainder of the report.

1. PROJECT UNDERSTANDING

1.1 Project Information

We understand the proposed project consists of the replacement of an existing pressure reducing valve (PRV) station. The new proposed PRV station will bear on a 10.5-foot by 10.5-foot concrete pad at a depth of approximately 8 to 10 feet below existing site grades.

If the foundation size or site grading significantly differs from these values, the geotechnical engineer should be contacted to verify that the recommendations contained in this report remain valid.

The need for and/or location(s) of potential retaining walls at the site have not been determined. The lateral earth pressures and any related allowable soil bearing pressure recommendations provided in this report are applicable only to the design of rigid below-grade or retaining walls subject to slight rotation, such as cast-in-place cantilever concrete walls.

1.2 Site Description

The proposed project site is located south of the intersection of East 86th Avenue and Madison Court in Thornton, Colorado. At the time of our field exploration, the site surface comprised grass and an asphalt sidewalk, and it was accessible to a truck-mounted drilling rig.

From our review of readily available historic aerial images, the nearby development was generally constructed prior to 1991. Residential dwellings surround the project site to the south, and commercial to the north. The approximate location of the new PRV station is shown in **Figure 1**.



Figure 1. 2023 Aerial Photograph/Project Location Plan.

2. SUBSURFACE CONDITIONS

2.1 Subsurface Profile

The appended borehole reports represent subsurface conditions at the specific boring location at the time of our field exploration; variations may occur between or beyond the boring. The stratification lines shown on the log represent the approximate boundary between material types. However, the transition between layers may be gradual. The depths referenced in the following paragraphs are relative to the site grade at the time of our exploration.

The subsurface soils at this site comprised existing fill materials, and native clays and sands. The general characteristics of each soil stratum are summarized below, with more detailed descriptions provided on the borehole report in [Appendix A](#).

Topsoil

We encountered a 5-inch-thick topsoil zone in the boring.

Existing Fill

We encountered existing fill materials beneath the topsoil extending to a depth of 2 feet below the existing grade. The fill was generally described as clayey gravel with sand (GC), brown, and dry.

Clay Soils

We encountered clay soils underlying the fill materials. The clay soils comprised sandy lean clay (CL) and were described as firm to stiff, yellowish tan, and dry to very moist.

Sand Soils

We encountered sand soils underlying the clay and extending to the termination depth of the boring. The sand soils comprised clayey sand (SC) and were described as loose to dense, fine to coarse grained, yellowish tan and brown, and moist to very moist.

2.2 Water Level Observations

Subsurface water was not encountered in the soil test borings at the time of drilling operations. However, water levels may fluctuate over time with variations in precipitation, site grading, drainage, and adjacent land use. Perched subsurface water conditions can also develop in seams of loose or granular soil.

Long-term monitoring with piezometers generally provides a more representative indication of the potential range of subsurface water conditions. Such monitoring was not completed as part of this exploration. Olsson can provide additional monitoring upon written request of the Owner

and/or Olsson's client. Recommendations for addressing effects of water in design and during construction are presented in **Section 4.3** of this report. Any foundation design must take into consideration changing water conditions.

2.3 Corrosivity of Soils

The results of laboratory soil chemistry testing consisting of water-soluble sulfates, pH, water-soluble chlorides, and resistivity are presented in **Appendix B**. The resistivity value indicates that the soils may be severely corrosive to buried metal. A mechanical/electrical designer, experienced with local building code requirements and local practice, should review the laboratory test results and determine if corrosion protection of buried utility lines is required and how it is to be implemented.

Laboratory results indicate soils on this site have an S0 exposure class for sulfate. Type I/II cement or equivalent is acceptable per ACI 201.2R, based on the sulfate levels of less than 0.1 percent by mass. An experienced designer should review these results and evaluate the suitability of proposed designs based on the corrosivity test results.

3. GEOTECHNICAL CONSIDERATIONS

On-site soils at the site were determined to have low expansion and low collapse potential based on our laboratory one-dimensional swell/consolidation testing. Expansive materials have the potential to undergo volume changes when exposed to increased moisture conditions. Volume changes within the supporting materials can result in movements that cause distress to overlying structures. Recommendations for the earthwork and construction considerations are provided in [Section 4](#).

It is our opinion that the proposed construction is suitable to be supported on a mat foundation. Our recommendations for the mat foundation are provided in [Section 5.1](#). The on-site existing fill materials and native soils consisted of clayey sands and sandy lean clays that appear suitable for reuse as structural fill.

Soils encountered across the project site may be susceptible to instability or softening under repetitive construction activities in combination with wet weather. Mitigation of soft soils may be required if unstable conditions develop. Discussions and recommendations regarding equipment mobility are provided in [Section 4.5](#). If unstable soils are encountered or become unstable during construction, removal and replacement with suitable fill or stabilization should be expected.

4. EARTHWORK AND CONSTRUCTION CONSIDERATIONS

The following sections discuss general earthwork and construction considerations for overall site preparation. Additional earthwork or soil improvements may be required beneath foundations. These additional recommendations, if applicable, are presented in [Section 5](#).

4.1 Site Preparation

Vegetation, topsoil, roots, pavements, and other deleterious materials deemed unsuitable by an Olsson geotechnical engineer, or their authorized field representative, should be removed from the proposed construction area and replaced with controlled fill. We recommend site clearing, grubbing, and stripping be performed during dry weather conditions. Operation of heavy equipment on the site during wet conditions could result in excessive rutting and mixing of organic debris with the underlying soils.

At the base of stripping operations or overexcavations and prior to the placement of structural fill, we recommend the top 8 inches of the exposed subgrade soils be scarified and recompacted in accordance with [Section 4.2](#) of this report.

Soils which cannot be adequately densified in-place should be removed and replaced with approved structural fill or stabilized under the direction of an Olsson representative. The extent of areas requiring removal or stabilization will depend on the conditions observed at the time of construction. Undercut areas should be backfilled with stable fill material similar in composition to the surrounding soils.

If necessary, one or more layers of crushed stone may be considered to stabilize areas where wet soil or water are present. Geogrid or geosynthetic fabric may be used in conjunction with the crushed stone to provide additional stabilization.

4.2 Structural Fill

We recommend that structural fill have a liquid limit less than 45, a plasticity index less than 25, and a maximum swell potential of 1 percent when remolded as structural fill under an inundation pressure of 500 psf. Soils with Atterberg limits greater than these values will require removal and replacement with suitable fill soils. All structural fill soils should also be relatively free of organic materials (less than about 2 percent by weight), debris, and particles larger than 3 inches in nominal diameter.

Samples of all proposed structural fill, including on-site soils, should be submitted to Olsson at least seven days before placement for testing and approval.

Proper lift thickness depends on the type of compaction equipment used, but we recommend a maximum lift thickness of 8 inches in loose measurement. Thinner lifts could be required in confined areas such as around the vault or within footing and utility trenches. Soils should be compacted using equipment of appropriate type and size to achieve the recommendations presented in this report. Water flooding is not an acceptable compaction method for any soil type.

We recommend that structural fill and backfill be compacted in accordance with the criteria stated in **Table 1**. Utility trenches, foundation excavations, and retaining walls should be backfilled as soon as possible to reduce the risk of water infiltration into the subgrade.

An Olsson field representative should periodically observe fill placement operations and perform field moisture-density tests to document whether moisture content and compaction requirements are being achieved.

The moisture content of suitable borrow soils should be within the ranges specified in **Table 1**. More stringent moisture limits may be necessary with certain soils. Adjustment of moisture content may be necessary to allow compaction in accordance with project specifications.

Table 1. Structural Fill Placement Guidelines.

Area of Fill Placement	Suitable Material (USCS or Description)	Compaction (ASTM D698 - Standard Proctor)	Moisture Content (Percent of Optimum)
Structural Fill – site grading or subgrade preparation below foundations	On-site soils or imported fill	95%*	-3 to +3 for cohesionless soils
Non-structural landscaped areas	On-site soils or imported soils	92%	Or Optimum to +3 for cohesive soils
<i>* Or 70 percent Relative Density as described below</i>			

Granular fill materials may not produce a definable moisture-density curve when tested in accordance with ASTM D698 (Standard Proctor). Such materials could alternatively be compacted to a minimum of 70 percent relative density as determined by ASTM D4253 (Standard Test Methods for Maximum Index Density and Unit Weight of Soils Using a Vibratory Table) and D4254 (Standard Test Methods for Minimum Index Density and Unit Weight of Soils and Calculations of Relative Density).

Controlled low strength material (CLSM) or flowable fill may be considered for utility or other small backfills. We recommend flowable fill have a compressive strength between 100 and 300 pounds per square inch (psi). CLSM with a maximum compressive strength less than 150 psi can be readily excavated with a backhoe. CLSM can be placed in a single lift, without personnel entering the excavation and without the need for compaction equipment.

4.3 Dewatering Considerations

We did not encounter groundwater at the time of our exploration. As such, we do not anticipate groundwater will impact construction activities. Variations in groundwater elevation could occur because of seasonal changes in rainfall, temperature, snowmelt, runoff, localized irrigation demand, or other factors. Saturated soils and higher groundwater elevations should be anticipated in areas near drainage channels and ditches.

The contractor should utilize their experience in this area and experience with similar projects to determine the most effective method of dewatering and the effects of such methods on nearby structures, utilities, or pavements.

4.4 Temporary Slopes and Excavations

Construction site safety is the sole responsibility of the general contractor. The contractor is also responsible for the means, methods, techniques, sequencing, and operations used during construction. Slope height, slope inclination, and excavation depths (including utility trench excavations) should in no case exceed those specified in local, state, or federal safety regulations.

4.5 Equipment Mobility

Some of the soils encountered at this site may be susceptible to softening under the action of construction equipment traffic in combination with wet weather. Mitigation of equipment mobility problems and management of soft surficial soils will depend on the severity of the problem, the season in which construction is performed, and prevailing weather conditions.

During construction, provisions should be made to quickly remove seepage water or storm water from excavations. Water should not be allowed to collect near foundations either during or after construction. Undercut or excavated areas should be sloped toward one corner to facilitate the collection and removal of rainwater or surface runoff. Site grading should provide rapid drainage of water away from the structure and pavement areas throughout construction.

Additional guidelines for reducing equipment mobility problems are as follows:

- Optimize surface water drainage at the site.

- Allow for rain days in the construction schedule and wait for dry weather conditions to prevail whenever possible. Avoid operating construction equipment on the site during wet conditions. Rutting the surface will aggravate mobility problems.
- Use construction equipment that is suited for the intended job under the site conditions. Heavy rubber-tired equipment typically requires better site conditions than light, track-mounted equipment.

Ultimately, it may be necessary to take steps to aggressively improve equipment mobility if construction must proceed under unfavorable conditions. More aggressive methods for addressing equipment mobility problems may range from removing several feet of soft wet soils to utilizing crushed stone materials and/or appropriate stabilization fabrics or geogrids. Other methods include chemical stabilization with Portland cement, fly ash, or cement kiln dust (CKD). The stabilization approach should be determined at the time of construction in consultation with an Olsson geotechnical engineer.

The contractor is responsible for creating and maintaining a stable working platform. Soils that are disturbed by construction activity or adverse weather conditions should be corrected by the contractor to conform with project specifications and this report.

5. STRUCTURES DESIGN

Based on the results of our borings, laboratory testing, and engineering evaluation, our opinion is that the subsurface conditions are suitable for supporting the proposed PRV station on a mat foundation.

5.1 Mat Foundations

In our opinion, the proposed slabs for the PRV station can be designed as a mat foundation if the recommendations of this report are followed. We recommend the foundation be supported by at least 1 foot of properly compacted structural fill. Structural fill soils should extend 1 foot laterally for every foot of overexcavation depth below the foundation and be moisture conditioned and recompacted in accordance with [Section 4.2](#).

Mat foundations should be designed for a maximum net allowable bearing pressure of 2,500 pounds per square foot (psf). The net allowable bearing capacity can be increased by 1/3 for transient loading such as wind or seismic. Mat foundations constructed on compacted structural fill are expected to experience total post-construction movements on the order of 1 inch and differential movements of approximately ½ inch.

The thickness and reinforcement for the mat foundation should be designed by the project structural engineer. A mat foundation can also be designed using a subgrade modulus value. If the structural designer would prefer this design methodology, Olsson recommends a modulus of subgrade reaction of 150 pounds per cubic inch (pci) for the design of the mat foundation bearing on approved structural fill as discussed in this report. This value is a unit value for use with a 1-foot square foundation. The modulus should be reduced in accordance with the following equation when used with larger foundations:

$$K_{(BxB)} = K_1 \left(\frac{1}{B} \right)$$

where $K_{(BxB)}$ is the subgrade modulus for a mat foundation (dimensions B x B), K_1 is the unit subgrade modulus (dimensions 1 foot by 1 foot), and B is the foundation width (in feet).

The following equation can be used to correct the modulus value for a rectangular foundation having dimensions B by L:

$$K_{(BXL)} = \frac{K_{(BxB)} \left(1 + 0.5 * \left(\frac{B}{L} \right) \right)}{1.5}$$

A friction coefficient value of 0.35 may be used for concrete mat foundations bearing directly against granular prepared subgrades or approved structural fill.

The long-term performance of the mat foundation will greatly depend on minimizing or reducing moisture infiltration into the backfill soils.

5.2 Lateral Earth Pressures

The following soil parameters are provided for designing cast-in-place concrete cantilevered retaining walls and/or foundation walls subject to lateral earth pressures. These parameters are based on the assumption that retained soils will be similar in composition to the on-site soils encountered during this investigation. These recommendations are not applicable to the design of modular block - geogrid reinforced backfill (MSE) or gravity block walls. Recommendations for these types of wall systems are beyond the scope of this report.

Walls which are rigidly restrained at the top and are essentially unable to deflect or rotate should be designed for at rest earth pressure conditions. Walls that are unrestrained at the top and are free to deflect or rotate slightly may be designed for active earth pressure conditions. The passive earth pressure condition is used to evaluate the resistance of soil to lateral loads. **Table 2** presents recommended values of earth pressure coefficients and equivalent fluid densities based on our experience with soils in the area.

Table 2. Earth Pressure Parameters.

Earth Pressure Coefficient (K)		Equivalent Fluid Density (G)		
			Drained Condition (pcf)	Undrained Condition (pcf)
At Rest (K₀)	Cohesive	0.56	60	90
	Granular*	0.50	55	--
Active (K_a)	Cohesive	0.39	45	80
	Granular*	0.33	40	--
Passive (K_p)	Cohesive	2.56	280	185
	Granular*	3.00	330	--

**Granular values may be used for design only if a drainage system is installed and the granular backfill extends upward from the base of the wall as noted below.*

The above parameters are based on the considerations noted below and are shown in **Figure 2**, below.

- Equivalent fluid densities do not include a factor of safety or consider the effects of hydrostatic pressure, surcharge loading (P_1), point loads, or construction equipment loads.
- Mobilization of active pressure requires the wall rotate about the base, with top-of-wall

movements (d) on the order of $0.002 \cdot Z$ to $0.004 \cdot Z$ (granular) or $0.010 \cdot Z$ to $0.020 \cdot Z$ (cohesive), where Z is the wall height.

- Mobilization of passive pressure requires a lateral wall movement (d) on the order of $0.020 \cdot Z$ to $0.060 \cdot Z$ (granular) or $0.020 \cdot Z$ to $0.040 \cdot Z$ (cohesive), where Z is the wall height.
- Drained earth pressure parameters assume a permanent drainage system is installed behind the wall to prevent the development of hydrostatic pressure.
- Backfill has a maximum unit weight of 110 pcf.
- The ground surface in front of and behind the wall is horizontal.

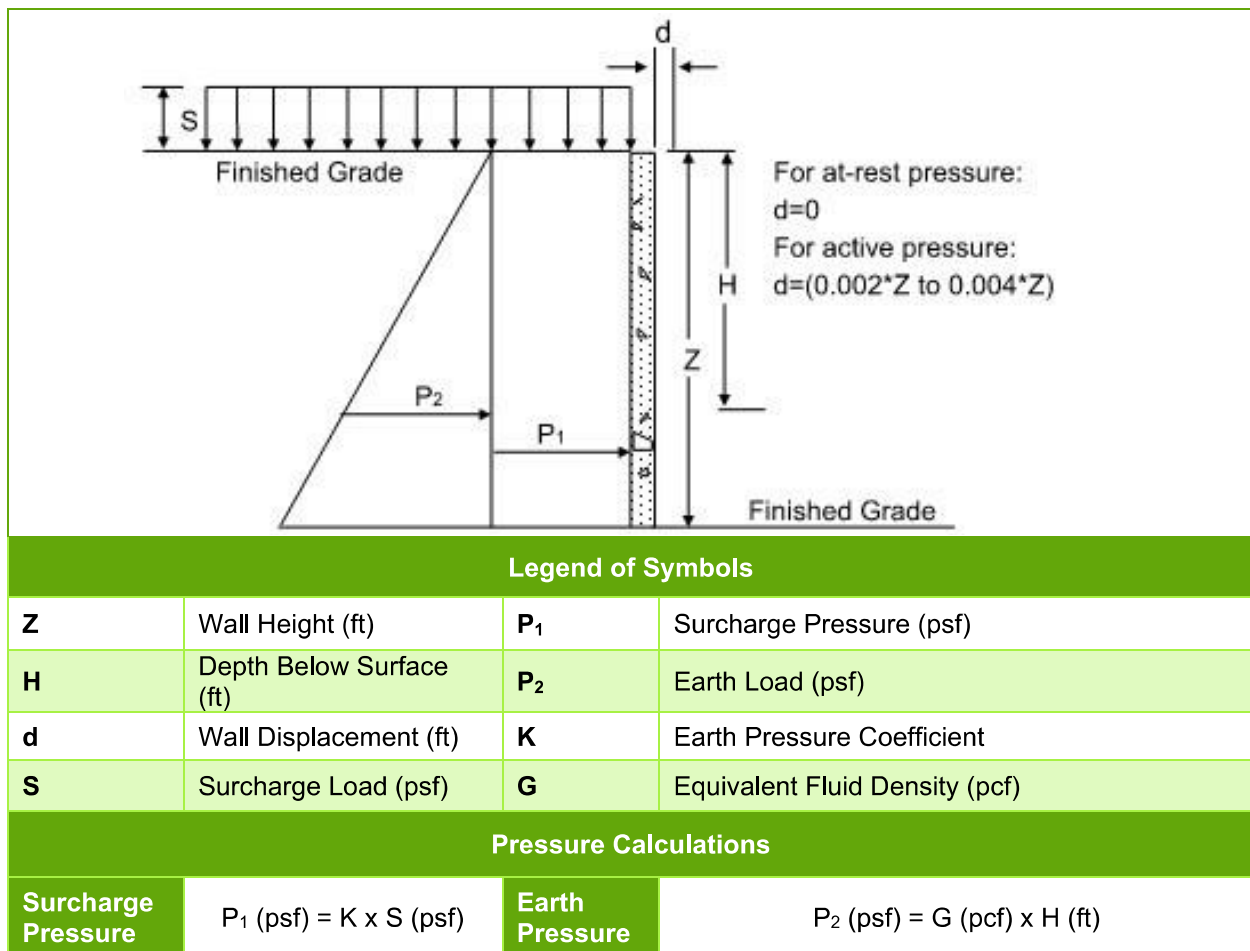

Figure 2. Lateral Earth Pressure Calculations.

Backfill soils placed within a lateral distance from the face of the wall to 70 percent of the wall height should consist of granular material or select lean clay with a liquid limit less than 45. To utilize earth pressure parameters for granular materials, the granular backfill must extend out

from the base of the wall at angles of 45 and 60 degrees from the vertical for the active and passive cases, respectively.

Sliding resistance along the base of a wall supported on suitable native soils or properly compacted structural fill may be evaluated using an ultimate sliding friction value of 0.35. Appropriate factors of safety should be applied to the calculated lateral earth pressures and sliding friction resistance. This factor of safety typically ranges from 1.5 to 2.0. Passive earth pressure resistance should be neglected within the frost zone (typically 3 feet).

If a foundation key is considered to resist lateral sliding loads using passive earth pressure, the key should be placed below the wall stem or to the toe side of the wall stem. Sliding resistance along the base of the foundation should be neglected within the passive earth pressure zone.

5.3 Seismic Site Classification

For this project site, the soil conditions encountered at the boring are consistent with Site Class “D” as defined by ASCE 7-22. Our review of the site class is based on the soil conditions encountered in the borings during the exploration and our assumption that the encountered soil conditions are underlain by similar native materials to those encountered which extend to a depth of 100 feet.

5.4 Permanent Slopes

We recommend permanent cut or fill slopes be shallower than 3(H):1(V) to maintain long-term stability and to provide ease of maintenance. The crest or toe of cut or fill slopes should be at least 10 feet from any foundation and at least 5 feet from the edge of any pavements. Permanent slopes should be vegetated as soon as practical to minimize the potential for erosion. Slopes steeper than 3(H):1(V) are susceptible to erosion, will be difficult to maintain, and could experience problems with instability. Such slopes may require additional slope stability analysis, which is beyond the scope of this report.

The performance of the proposed structure depends on maintaining the moisture content of the subgrade soils throughout the life of the facility. To reduce the effects of moisture infiltration near the structure, efficient drainage of rainfall or surface runoff should be provided. We recommend a minimum slope of 2 percent for pavement areas and 5 percent for grass or landscaped areas.

6. REPORT LIMITATIONS

The conclusions and recommendations presented in this report are based on the information available regarding the proposed construction, geotechnical information obtained from our field exploration and laboratory testing, as well as our experience with similar projects. Our borings and testing represent a limited statistical sampling of the subsurface. Conditions may be encountered during construction that are substantially different from those encountered in this exploration and adjustments to design and construction may be necessary.

In the event of any changes in the nature of the proposed project as outlined in this report, the opinions in this report cannot be considered valid unless Olsson reviews the changes, and the opinions of this report are modified or affirmed by Olsson.

The scope of this exploration did not include any environmental assessment for the presence of wetlands and/or hazardous or toxic materials in the soil or groundwater on or near the site. Any statements in this report regarding odors, discoloration, or suspicious conditions are strictly for the information of our client.

This report is based on generally accepted professional geotechnical engineering practice at the time of this report, within this geographic area. No warranty, express or implied, is intended or made. This report has been prepared for the exclusive use of the City of Thornton and their authorized representatives for specific application to the discussed project.

APPENDIX A

Exploration Maps, Log, and Information

Field Exploration

Our drill crew advanced the boring for this exploration with a truck-mounted drill rig using continuous-flight augers. The boring location was identified in the field by the drill crew using a hand-held GPS unit. The approximate location of the boring is shown on the Boring Location Map.

Samples were obtained using the methods and at the depths shown on the log. Recovered samples were sealed in containers, labeled, and protected for transportation to the laboratory for testing.

We interpolated the ground surface elevation at the boring location using a topographic map provided by Olsson. The surface elevations at the boring location, rounded to the nearest half-foot, are presented on the boring logs.

The drill crew prepared the field boring log during drilling operations. The field log includes drilling and sampling methods, sampling intervals, groundwater measurements, and general descriptions of the observed soil conditions. The final boring log represents our engineering interpretation of the field log based on visual classification and laboratory testing of the collected samples.

EAST 86TH AVENUE

B-1

MADISON COURT



LEGEND

 SOIL BORING LOCATION

PROJECT NO: 025-02626

DRAWN BY: RARE

DATE: 03.19.2026

**BORING LOCATION MAP
PRV STATION REPLACEMENT
THORNTON, COLORADO**

olsson

BORING LOG NO. B-1

Sheet 1 of 1

PROJECT NAME East 86th and Madison Court PRV Station Replacement	CLIENT City of Thornton
PROJECT NUMBER 025-02626	LOCATION Thornton, CO

ELEVATION (ft)	MATERIAL DESCRIPTION	GRAPHIC LOG	DEPTH (ft)	SAMPLE TYPE NUMBER	CLASSIFICATION (USCS)	BLOWS/6" (N-VALUE)	UNC STR (tsf)	MOISTURE (%)	DRY DENSITY (pcf)	LL/PI (%)	ADDITIONAL DATA/REMARKS
	LAT: 39.852153 LONG: -104.946827 APPROX. SURFACE ELEV. (ft):5115.5										
5111.0	TOPSOIL, 5 inches thick FILL, CLAYEY GRAVEL WITH SAND brown, dry	0.4'	1	MC-1		6-12		2.6			
	SANDY LEAN CLAY (CL), stiff to firm, yellowish tan, dry to moist	2.0'	2								
			3								
			4	SPT-2		7-7-8 (15)		9.1			
			5								
			6	MC-3		5-4		16.8	104.7	42/24	
			7								
5106.0	CLAYEY SAND (SC), loose, yellowish tan, moist, fine to medium sand	8.0'	8								
			9	SPT-4		3-4-4 (8)		26.1			
			10								
			11								
			12								
5101.0	SANDY LEAN CLAY (CL), stiff, yellowish tan, very moist	12.0'	13								
			14	MC-5		4-6		33.8	84.9		
			15								
			16								
			17								
5096.0	CLAYEY SAND (SC), dense, brown, very moist, fine to coarse sand, with fine gravel	18.0'	18								
			19	SPT-6		14-24-18 (42)		25.5			
			20								
			21								
			22								
			23								
5091.0	BASE OF BORING AT 24.5 FEET	24.5'	24	MC-7		18-21					
			25								
			26								
			27								
5086.0			28								
			29								
			30								
			31								
			32								
			33								
5081.0			34								

WATER LEVEL OBSERVATIONS			STARTED: 02/10/2026	FINISHED: 02/10/2026
WD	Not Encountered		DRILL CO.: Vine Labs	EQUIPMENT: CME 75
IAD	Not Encountered		DRILLER: Vine Labs	LOGGED BY: M. Almand
AD	Not Performed		METHOD: Continuous Flight Auger	

SYMBOLS AND NOMENCLATURE

DRILLING NOTES

DRILLING AND SAMPLING SYMBOLS

SS: Split-Spoon Sample (1.375" ID, 2.0" OD)	HSA: Hollow Stem Auger	NE: Not Encountered
U: Thin-Walled Tube Sample (3.0" OD)	CFA: Continuous Flight Auger	NP: Not Performed
CS: Continuous Sample	HA: Hand Auger	NA: Not Applicable
BS: Bulk Sample	CPT: Cone Penetration Test	% Rec: Percent Recovery
MC: Modified California Sampler	WB: Wash Bore	WD: While Drilling
GB: Grab Sample	RB: Rock Bit	IAD: Immediately After Drilling
SPT: Standard Penetration Test Blows per 6.0"	PP: Pocket Penetrometer	AD: After Drilling

DRILLING PROCEDURES

Soil samples designated as "U" samples on the boring logs were obtained using thin-walled tube sampling techniques. Soil samples designated as "SS" samples were obtained using a split-spoon barrel sampler while performing Standard Penetration Tests (SPT). The standard penetration resistance 'N' value is the number of blows to drive the split-spoon sampler 1 foot using a 140-pound hammer falling 30 inches. Soil samples designated as "MC" were obtained in using thick-walled, ring-lined, split-barrel drive sampling techniques (Modified California sampler). Recovered samples were sealed in containers, labeled, and protected for transportation to the laboratory for testing.

WATER LEVEL MEASUREMENTS

Water levels indicated on the boring logs are levels measured in the borings at the times indicated. In highly permeable materials, the indicated levels may reflect the location of groundwater. In low permeability soils, the accurate determination of groundwater levels is not possible with only short-term observations.

SOIL PROPERTIES & DESCRIPTIONS

Descriptions of the soils encountered in the soil test borings were prepared using Visual-Manual Procedures for Descriptions and Identification of Soils.

PARTICLE SIZE

Boulders	12 in. +	Coarse Sand	4.75mm-2.0mm	Silt	0.075mm-0.002mm
Cobbles	12 in.-3 in.	Medium Sand	2.0mm-0.425mm	Clay	<0.002mm
Gravel	3 in.-4.75mm	Fine Sand	0.425mm-0.075mm		

COHESIVE SOILS

Unconfined Compressive

<u>Consistency</u>	<u>Strength (Qu) (tsf)</u>
Very Soft	<0.25
Soft	0.25 – 0.5
Firm	0.5 – 1.0
Stiff	1.0 – 2.0
Very Stiff	2.0 – 4.0
Hard	> 4.0

COHESIONLESS SOILS

<u>Relative Density</u>	<u>'N' Value</u>
Very Loose	0 – 3
Loose	4 – 9
Medium Dense	10 – 29
Dense	30 – 49
Very Dense	≥ 50

COMPONENT %

<u>Description</u>	<u>Percent (%)</u>
Trace	<5
Few	5 - 10
Little	15 - 25
Some	30 - 45
Mostly	50 - 100

PLASTICITY CHART

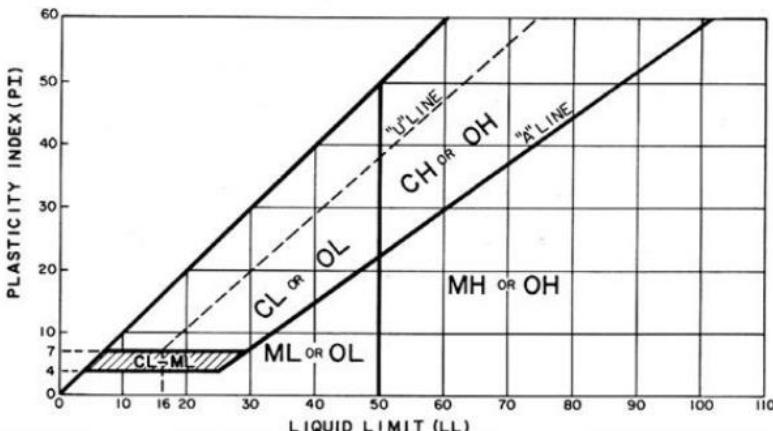



ROCK QUALITY DESIGNATION (RQD)

<u>Description</u>	<u>RQD (%)</u>
Very Poor	0 – 25
Poor	25 – 50
Fair	50 – 75
Good	75 – 90
Excellent	90 – 100

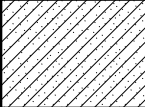
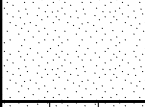
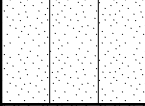
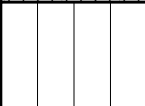
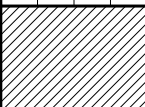
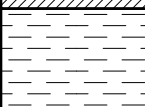
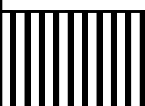
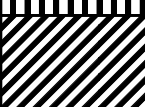
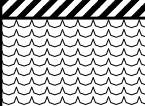
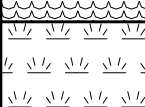

SOIL CLASSIFICATION CHART

MAJOR DIVISIONS			SYMBOLS		TYPICAL DESCRIPTIONS	
			GRAPH	LETTER		
COARSE GRAINED SOILS MORE THAN 50% OF MATERIAL IS LARGER THAN NO. 200 SIEVE SIZE	GRAVEL AND GRAVELLY SOILS MORE THAN 50% OF COARSE FRACTION RETAINED ON NO. 4 SIEVE	CLEAN GRAVELS (LITTLE OR NO FINES)		GW	WELL-GRADED GRAVELS, GRAVEL - SAND MIXTURES, LITTLE OR NO FINES	
		GRAVELS WITH FINES (APPRECIABLE AMOUNT OF FINES)		GP	POORLY-GRADED GRAVELS, GRAVEL - SAND MIXTURES, LITTLE OR NO FINES	
		CLEAN SANDS (LITTLE OR NO FINES)		SW	WELL-GRADED SANDS, GRAVELLY SANDS, LITTLE OR NO FINES	
		SANDS WITH FINES (APPRECIABLE AMOUNT OF FINES)		SC	CLAYEY SANDS, SAND - CLAY MIXTURES	
	SAND AND SANDY SOILS MORE THAN 50% OF COARSE FRACTION PASSING ON NO. 4 SIEVE	CLEAN SANDS (LITTLE OR NO FINES)		SP	POORLY-GRADED SANDS, GRAVELLY SAND, LITTLE OR NO FINES	
		SANDS WITH FINES (APPRECIABLE AMOUNT OF FINES)		SM	SILTY SANDS, SAND - SILT MIXTURES	
		SILTS AND CLAYS LIQUID LIMIT LESS THAN 50	SANDS WITH FINES (APPRECIABLE AMOUNT OF FINES)		ML	INORGANIC SILTS AND VERY FINE SANDS, ROCK FLOUR, SILTY OR CLAYEY FINE SANDS OR CLAYEY SILTS WITH SLIGHT PLASTICITY
			SANDS WITH FINES (APPRECIABLE AMOUNT OF FINES)		CL	INORGANIC CLAYS OF LOW TO MEDIUM PLASTICITY, GRAVELLY CLAYS, SANDY CLAYS, SILTY CLAYS, LEAN CLAYS
			SANDS WITH FINES (APPRECIABLE AMOUNT OF FINES)		OL	ORGANIC SILTS AND ORGANIC SILTY CLAYS OF LOW PLASTICITY
		SILTS AND CLAYS LIQUID LIMIT GREATER THAN 50	SANDS WITH FINES (APPRECIABLE AMOUNT OF FINES)		MH	INORGANIC SILTS, MICACEOUS OR DIATOMACEOUS FINE SAND OR SILTY SOILS
SANDS WITH FINES (APPRECIABLE AMOUNT OF FINES)			CH	INORGANIC CLAYS OF HIGH PLASTICITY		
SANDS WITH FINES (APPRECIABLE AMOUNT OF FINES)			OH	ORGANIC CLAYS OF MEDIUM TO HIGH PLASTICITY, ORGANIC SILTS		
HIGHLY ORGANIC SOILS				PT	PEAT, HUMUS, SWAMP SOILS WITH HIGH ORGANIC CONTENTS	

NOTE: DUAL SYMBOLS ARE USED TO INDICATE BORDERLINE SOIL CLASSIFICATIONS

APPENDIX B

Laboratory Test Results



ASTM D4546
One-Dimensional Swell or Collapse of Soils

Project Information			
Project Name:	East 86th and Madison Court PRV Station Replacement		
Project Number:	025-02626		
Client Name:	City of Thornton		
Sample Information	Test Results		
Boring No.:	B-1	Before	After
Sample No.:	MC-3	Specimen Mass (g)	94.8 96.6
Depth (ft):	6 - 7	Water Content (%):	16.8 16.8
Date Tested:	March 5, 2026	Dry Unit Weight (pcf):	104.7 120.9
Sample Description:	Sandy Lean Clay, Yellowish Tan	Saturation (%):	76.8 100.0
Test Information	Void Ratio:		
Test Method:	C	Initial Height, h (in.):	1.000
Preparation Method:	Intact	Height After Swell, h1 (in.):	1.004
Water Type:	Potable	Magnitude of Swell (%):	0.4
Inundation Pressure (tsf):	0.50	Swell Pressure (tsf):	1.0
Atterberg Results	Final Height, h2 (in):		
Liquid Limit:	42	Plastic Limit:	18
Plasticity Index:	24	Remarks	

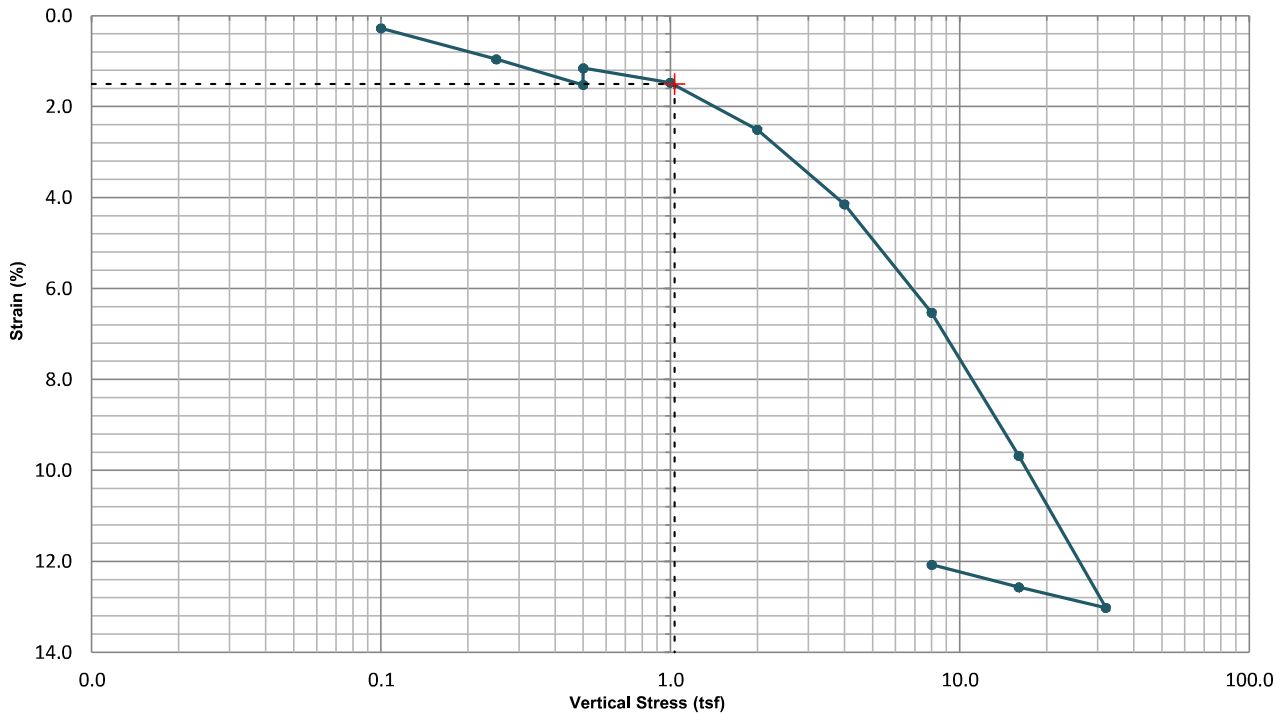



ASTM D4546
One-Dimensional Swell or Collapse of Soils

Project Information			
Project Name:	East 86th and Madison Court PRV Station Replacement		
Project Number:	025-02626		
Client Name:	City of Thornton		
Sample Information	Test Results		
Boring No.:	B-1	Before	After
Sample No.:	MC-5	Specimen Mass (g)	87.9 81.1
Depth (ft):	13.5 - 14.5	Water Content (%):	33.8 25.3
Date Tested:	March 5, 2026	Dry Unit Weight (pcf):	84.9 108.6
Sample Description:	Sandy Lean Clay, Yellowish Tan	Saturation (%):	94.3 100.0
Test Information	Atterberg Results		
Test Method:	C	Void Ratio:	0.950 0.522
Preparation Method:	Intact	Initial Height, h (in.):	1.000
Water Type:	Potable	Height After Swell, h1 (in.):	0.999
Inundation Pressure (tsf):	0.10	Magnitude of Collapse (%):	-0.1
		Swell Pressure (tsf):	--
		Final Height, h2 (in):	
			0.769
		Remarks	
Liquid Limit:	--	Plastic Limit:	--
Plasticity Index:	--		

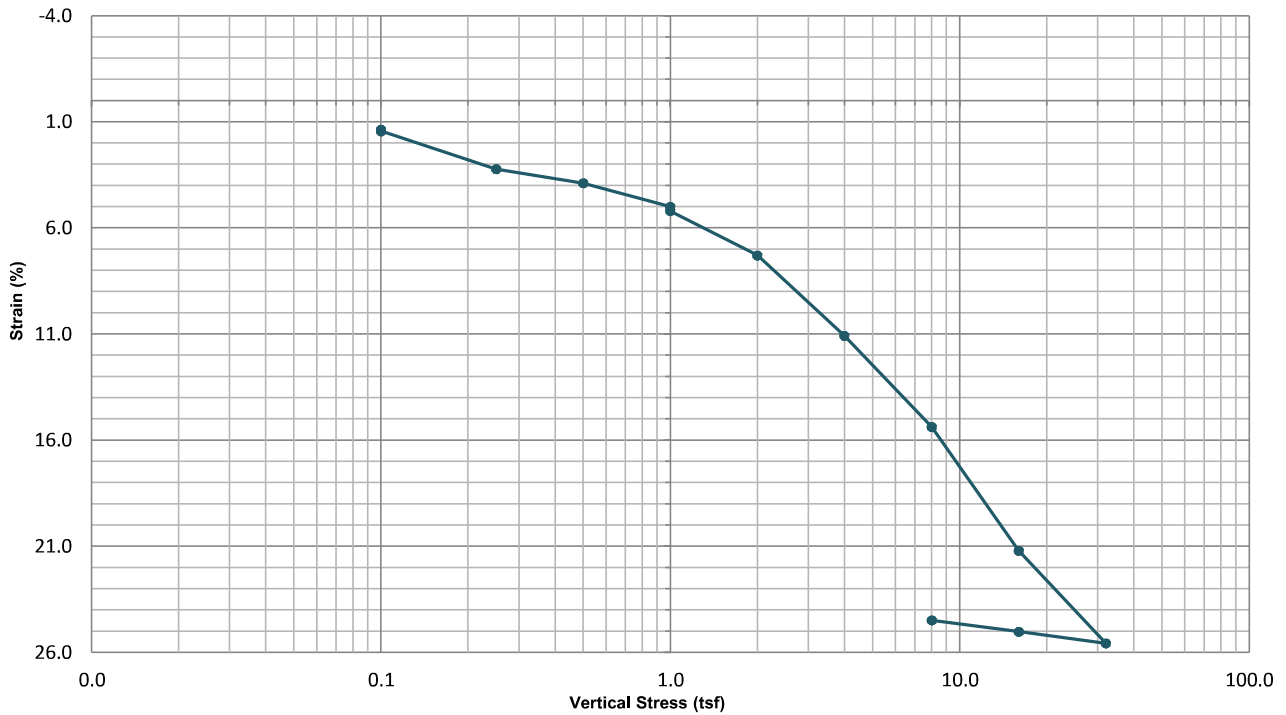



5180 Smith Road
Denver, CO 80216

TEL 303.237.2072
FAX 303.237.2659

www.olsson.com

Soil Corrosion Suite

Project Information	
Project Name:	East 86th and Madison Court PRV Station Replacement
Project Number:	025-02626
Client Name:	City of Thornton
Project Location:	Thornton, CO
Sample and Test Information	
Sample Location:	B-1 Bulk 1-3'
Sample Description:	Sandy Lean Clay with Gravel, Brown
Laboratory Technician:	Nathan Rasmussen
Date Tested:	3/5/2026
Test Results	

Water Soluble Sulfate (Colorado Procedure CP-L-2103)			
Dilution	Reading	Concentration, mg/L	Concentration, % mass
100:1	0	0	0
*N/D - Not Detected - Concentration was below the equipment detection limit of 0.1% mass			

Water Soluble Chloride (Colorado Procedure CP-L-2104)		
Dilution	Concentration, ppm	Concentration, % mass
2	66	0.0066

pH (ASTM G51)	
pH Meter Reading	
8.15	

Electrical Resistivity (ASTM G57, #10)			
Temperature (°C)	Readings (ohm*cm)	Temp Correction (ohm*cm)	
23	2210	2624	
23	1430	1698	
23	1000	1188	
23	917	1089	
23	933	1108	Lowest Resistivity (ohm*cm)
			1089

Sample portion passing the #10 sieve used in testing. Each reading performed after additional water was added.

EAST 86TH AND MADISON COURT PRV STATION REPLACEMENT

Thornton, Colorado

March 2026

Olsson Project No. 025-02626

APPENDIX B
SUE REPORT

CITY OF THORNTON 2025 TREATED WATER SYSTEM IMPROVEMENTS

SUE INVESTIGATION

FOR OLSSON



**Engineering
& Design**

www.colliersengineering.com
Copyright © 2025, Colliers Engineering & Design. All Rights Reserved. This drawing and all the information contained herein is authorized for use only by the party for whom the services were contracted or to whom it is certified. This drawing may not be copied, reused, disclosed, distributed or relied upon for any other purpose without the express written consent of Colliers Engineering & Design.

INDEX OF SHEETS		
SHT. No.	DESCRIPTION	LATEST REVISION
1	COVER SHEET	-
2	LEGEND & NOTES	-
3	UTILITIES PLAN	2



SHEET INDEX MAP
SOURCE: GOOGLE EARTH
NTS

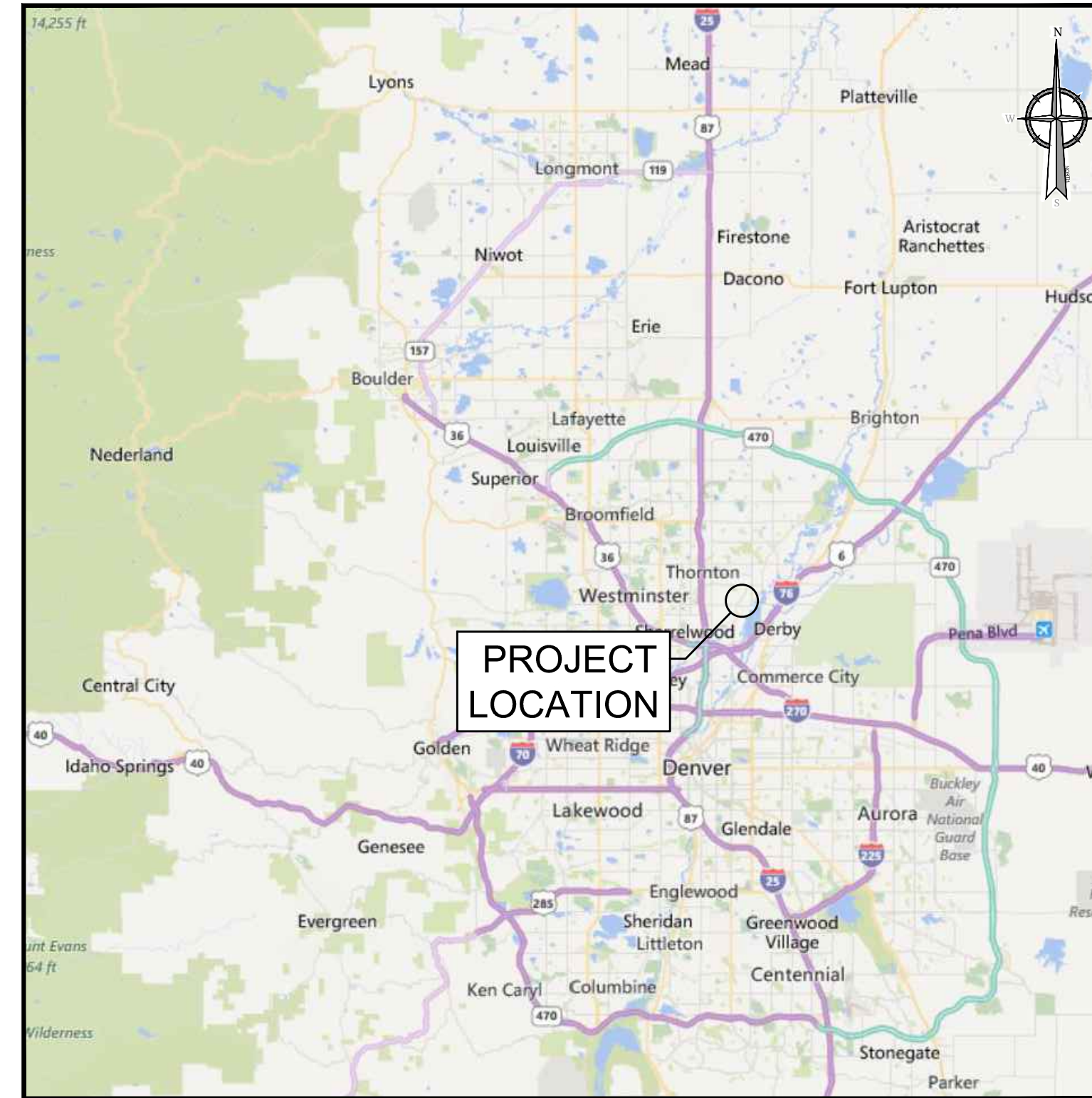

SHEET INDEX MAP
SOURCE: GOOGLE EARTH
NTS

SUBSURFACE UTILITY ENGINEERING	
MANAGER:	
COLLIERS ENGINEERING & DESIGN	
ADDRESS	365 INVERNESS PARKWAY, SUITE 100 ENGLEWOOD, CO 80112
CONTACT	STEVEN WHEELER, PE
PHONE NUMBER	(720) 716 - 5188
EMAIL	STEVEN.WHEELER@COLLIERSENG.COM

CLIENT:	
OLSSON	
ADDRESS	1525 RALEIGH ST SUITE 400, DENVER, CO 80204
CONTACT	CHANCE UHRICH
PHONE NUMBER	(303) 237-2072
EMAIL	CUHRICH@OLSSON.COM

REV	DATE	DESCRIPTION
1	10/1/25	ADDED WATER VALVE.
2	1/22/26	CHANGED DATUM. ADDED QL-A DATA.

811

PROTECT YOURSELF
ALL STATES REQUIRE
NOTIFICATION OF
EXCAVATORS, DESIGNERS, OR
ANY PERSON PREPARING TO
DISTURB THE EARTH'S SURFACE
ANYWHERE IN ANY STATE
Call before you dig.

FOR STATE SPECIFIC DIRECT PHONE NUMBERS
VISIT: WWW.CALL811.COM

UTILITY OWNER CONTACT LIST			
UTILITY OWNER	CONTACT NAME	PHONE NUMBER	EMAIL
CITY OF THORNTON	MARK MAZZUCCO	720-977-6279	MARK.MAZZUCCO@THORNTONCO.GOV
COMCAST	DAN CRUZ	720-237-1622	DANCRUZ@COMCAST.COM
CENTURYLINK	DUSTIN JACK	303-995-2859	DUSTIN.JACK@LUMEN.COM
XCEL ENERGY	LINDSEY SMILEY	303-445-4504	LINDSEY.E.SMILEY@XCELENERGY.COM

OLSSON

SUE INVESTIGATION
FOR
CITY OF THORNTON
2025 TREATED WATER
SYSTEM
IMPROVEMENTS

CITY OF THORNTON
ADAMS COUNTY
COLORADO



**Engineering
& Design**

DENVER

365 Inverness Pkwy.
Suite 100
Englewood, CO 80112
Phone: 303.731.6216
COLLIERS ENGINEERING & DESIGN, INC.

SCALE:	DRAWN BY:
AS SHOWN	SJB
DESIGNED BY:	REVIEWED BY:
SWW	SWW
DATE ISSUED:	PROJECT NUMBER:
9/26/25	25007025A
SHEET NAME:	

COVER SHEET

DRAWING NUMBER:
1 of 3

C:\Users\jwheeler\OneDrive\Desktop\Projects\2025\Thornton\2025 Treated Water System Improvements\Drawings\25007025A.dwg 1: COVER SHEET By: SWW/EEB on 2025-01-22 - 08:57 am

LEGEND

	ELECTRIC MANHOLE (VAULT)		DRAINAGE INLET (CURB & SQ.)
	ELECTRIC METER		STORM (DRAIN) MANHOLE
	LIGHT POLE		FLARED END SECTION
	ELECTRIC TRANSFORMER		SANITARY MANHOLE
	UTILITY HAND HOLE		GAS MANHOLE
	FIBER HANDHOLE		SIGN
	TELEPHONE MANHOLE		GUY WIRE & ANCHOR
	TELEPHONE\CTV PEDESTAL		TRAFFIC SIGNAL POLE
	HYDRANT		FLAG POLE
	WATER VALVE		END OF INFORMATION (EOI)(COLOR VARIES)
	WATER MANHOLE		DESIGNATED END POINT (DEP)(COLOR VARIES)
	IRRIGATION VALVE		RAILROAD CROSSING LIGHT/GATE
	UTILITY VENT		

	RCP	REINFORCED CONCRETE PIPE	TEL	TELEPHONE
	CPP	CORRUGATED PLASTIC PIPE	VCP	VITRIFIED CLAY PIPE
	DIP	DUCTILE IRON PIPE	HDPE	HIGH-DENSITY POLYETHYLENE PIPE
	CIP	CAST IRON PIPE	DD	DIGITAL DEPTH
			APPROX	APPROXIMATE

	UNDERGROUND GAS LINE (QUALITY LEVEL D)
	UNDERGROUND SANITARY SEWER LINE (QUALITY LEVEL D)
	UNDERGROUND STORM LINE (QUALITY LEVEL D)
	OVERHEAD WIRE (QUALITY LEVEL D)
	UNDERGROUND IRRIGATION LINE (QUALITY LEVEL D)
	QL-B INVESTIGATION LIMITS
	PARCEL LINE
	UNDERGROUND WATER LINE (QUALITY LEVEL B)
	UNDERGROUND FIBER OPTIC LINE (QUALITY LEVEL B)
	UNDERGROUND CABLE TELEVISION LINE (QUALITY LEVEL B)
	UNDERGROUND TELEPHONE LINE (QUALITY LEVEL B)
	UNDERGROUND ELECTRIC LINE (QUALITY LEVEL B)
	UNDERGROUND TRAFFIC CONTROL LINE (QUALITY LEVEL B)
	UNDERGROUND GAS LINE (QUALITY LEVEL B)
	UNDERGROUND IRRIGATION LINE (QUALITY LEVEL B)
	UNDERGROUND UNKNOWN LINE (QUALITY LEVEL B)
	UNDERGROUND STORM CULVERT WALL (QUALITY LEVEL C)
	UNDERGROUND STORM LINE (QUALITY LEVEL C)
	UNDERGROUND SANITARY SEWER LINE (QUALITY LEVEL C)
	UNDERGROUND WATER LINE (QUALITY LEVEL D)
	UNDERGROUND FIBER OPTIC LINE (QUALITY LEVEL D)
	UNDERGROUND CABLE TELEVISION LINE (QUALITY LEVEL D)
	UNDERGROUND TELEPHONE LINE (QUALITY LEVEL D)
	UNDERGROUND ELECTRIC LINE (QUALITY LEVEL D)

GENERAL NOTES

- THE PURPOSE OF THIS DRAWING IS TO PROVIDE OLSSON WITH A LOCATION SURVEY OF THE EXISTING UTILITY INFRASTRUCTURE AROUND THE FOLLOWING AREA:
FROM THE END OF MADISON CT NORTH TO THE EDGE OF ROW ON E. 86TH AVE.
- WHERE INDICATED, SUBSURFACE UTILITIES HAVE BEEN DEPICTED IN ACCORDANCE WITH ASCE 38-22 STANDARD GUIDELINE FOR THE COLLECTION AND DEPICTION OF EXISTING SUBSURFACE UTILITY DATA. UNLESS OTHERWISE NOTED OR DEPICTED, UTILITY SEGMENTS SHOWN HEREON ARE QUALITY LEVEL B (QL-B) DATA THAT WERE DESIGNATED THROUGH THE APPLICATION OF APPROPRIATE SURFACE GEOPHYSICAL METHODS. SURFACE GEOPHYSICAL TECHNIQUES WERE UTILIZED TO DETERMINE THE EXISTENCE AND APPROXIMATE HORIZONTAL POSITION OF THE INDICATED SUBSURFACE UTILITIES. IN ACCORDANCE WITH THE ASCE 38-22 STANDARD, QL-B DATA SHOULD BE REPRODUCIBLE BY SURFACE GEOPHYSICS AT ANY POINT OF THEIR DEPICTION. THIS INFORMATION WAS SURVEYED TO APPLICABLE TOLERANCES DEFINED BY THE PROJECT AND REDUCED ONTO PLANNED DOCUMENTS. THE USER OF THESE DOCUMENTS SHALL BE AWARE THAT THE HORIZONTAL LOCATION MARKS SHOWN HEREON AS RELATED TO DESIGNATING AND LOCATING ACTIVITIES MAY NOT INTERSECT THE HORIZONTAL ALIGNMENT, AND ANY CORRESPONDING DEPTH VALUES ARE APPROXIMATE AND REQUIRE VERIFICATION PRIOR TO CONSTRUCTION.
- UTILITY SEGMENTS INDICATED HEREON AS QUALITY LEVEL A (QL-A) DATA WERE OBTAINED, WHERE POSSIBLE, THROUGH EXPOSURE OF THE UTILITY LINE THROUGH MINIMALLY INTRUSIVE EXCAVATION, BY MANUALLY MEASURING DOWN FROM THE EXISTING GRADE, AND SURVEYING APPLICABLE TOLERANCES TO DETERMINE BOTH HORIZONTAL AND VERTICAL LOCATIONS OF THE SUBSURFACE UTILITIES. UTILITY LINE DEPTHS SHOWN HEREON, WHEN INDICATED AS A PHYSICAL MEASUREMENT THROUGH EXPOSURE, ARE MEASURED TO THE TOP OF THE UTILITY INFRASTRUCTURE WITH THE EXCEPTION OF PIPE INVERTS FOR GRAVITY-FED SYSTEMS. DEPTHS AT TOP OF PIPES FOR GRAVITY-FED SYSTEMS ARE SHOWN AT APPROXIMATE DEPTHS BASED ON INVERT MEASUREMENTS. POTENTIAL CONFLICT LOCATIONS SHOWING INVERT ELEVATIONS ARE BASED ON CALCULATED INTERPOLATIONS FROM THE GRAVITY-FED SYSTEMS INVERT SURVEY DATA.
- WHEN EXCAVATION DID NOT OCCUR, A DIGITAL DEPTH (DD) MAY BE OBTAINED THROUGH THE USE OF ELECTROMAGNETIC INSTRUMENTS. DIGITAL DEPTHS SHOWN HEREON ARE APPROXIMATE, ARE FOR INFORMATION PURPOSES ONLY, AND REQUIRE VERIFICATION BY THE USER OF THIS DOCUMENT. THE USER OF THESE DOCUMENTS IS CAUTIONED THAT DIGITAL DEPTHS AND SUBSEQUENTLY DERIVED UTILITY PROFILES ARE SUBJECT TO LIMITATIONS AND POTENTIAL ERROR. ELECTROMAGNETICALLY-COLLECTED SUBSURFACE UTILITY DATA CAN BE INFLUENCED BY FACTORS BEYOND OUR CONTROL INCLUDING, BUT NOT LIMITED TO, CONDUCTIVITY OF MATERIALS AND THEIR SURROUNDINGS, SOIL MOISTURE, DEPTH OF THE TARGETED UTILITY INFRASTRUCTURE, AND PROXIMITY OF OTHER UNDERGROUND UTILITIES OR STRUCTURES. OUR PERSONNEL MADE EVERY REASONABLE EFFORT TO PROPERLY IDENTIFY AND INTERPRET ELECTROMAGNETIC DEPTH MEASUREMENTS IN ACCORDANCE WITH THE PERFORMANCE LIMITATIONS OF THE TECHNOLOGY USED AND TO PROVIDE THE RESULTING INFORMATION IN ACCORDANCE WITH SOUND ENGINEERING JUDGMENT AND PROPER STANDARD OF CARE FOR THE SUBSURFACE UTILITY ENGINEERING (SUE) INDUSTRY. ELECTROMAGNETIC EQUIPMENT MANUFACTURERS STATE DEPTH VARIABLES OF GREATER THAN + OR - 10% OF THE MEASURED DEPTH + 1/2 OF THE PIPE DIAMETER OF THE TARGETED UTILITY INFRASTRUCTURE. THEREFORE, ELECTROMAGNETIC DEPTH MEASUREMENTS (I.E. DIGITAL DEPTHS) AND SUBSEQUENTLY DERIVED UTILITY PROFILES ARE STRICTLY CONSIDERED A "VALUE-ADDED" SERVICE AND ARE NOT WARRANTED TO MEET A SPECIFIC DEGREE OF ACCURACY AND ALL SUCH DATA IS PROVIDED FOR INFORMATION PURPOSES ONLY. THE USE OF SUCH DATA / INFORMATION CONTAINED HEREON DOES NOT ALLEVIATE THE USER'S RESPONSIBILITY TO UTILIZE THEIR PRUDENT ENGINEERING JUDGMENT OR TO CONDUCT UTILITY DEPTH VERIFICATION / INVESTIGATION THROUGH VACUUM EXCAVATION TEST HOLES OR OTHER SUITABLE MEANS ACCEPTABLE TO THE UTILITY OWNER.
- OTHER UTILITY INFRASTRUCTURE WHICH WERE NOT OBSERVED AND ARE NOT SHOWN HEREON MAY EXIST. IT IS THE RESPONSIBILITY OF THE USER OF THESE DOCUMENTS TO VERIFY THOSE UTILITY LOCATIONS PRIOR TO THE COMMENCEMENT OF ANY CONSTRUCTION. COLLIERS ENGINEERING & DESIGN CANNOT ASSUME RESPONSIBILITY FOR MISIDENTIFICATION OR OMISSION OF ANY UNDERGROUND UTILITY INFORMATION.
- THE USER OF THESE DOCUMENTS IS CAUTIONED THAT EXISTING UTILITY LINES DEPICTED HEREON MAY END AT OR NEAR THE LIMIT OF THE PROJECT OR INVESTIGATIONAL AREA AND MAY APPEAR AS "DEAD ENDS" BUT ACTUALLY MAY CONTINUE BEYOND THE EXTENTS OF DESIGNATION AND LOCATION DEPICTED HEREON.
- PROPERTY LINES AND RIGHT-OF-WAY LINES SHOWN HEREON PER INFORMATION OBTAINED FROM PROJECT COUNTY GIS.
- THIS LOCATION SURVEY OF THE EXISTING UTILITY INFRASTRUCTURE DOES NOT REPRESENT A LAND SURVEY PLAT, AN IMPROVEMENT SURVEY PLAT OR A BOUNDARY SURVEY. THIS LOCATION SURVEY IS BASED ON EXISTING PHYSICAL EVIDENCE THAT WAS OBTAINED DURING THE FOLLOWING DATES: 9/16/25-9/26/25 (QL-B).
- THE ENGINEER'S SEAL HEREON IS TO CERTIFY THAT THE UTILITY INFRASTRUCTURE SHOWN HEREON HAVE BEEN INVESTIGATED IN THE IMMEDIATE VICINITY OF THE PROPOSED INFRASTRUCTURE ONLY AND IN ACCORDANCE WITH STANDARD SUE INDUSTRY PRACTICES AS DESCRIBED ABOVE, IN ORDER TO ESTIMATE THE HORIZONTAL & VERTICAL LOCATIONS OF EXISTING UTILITY INFRASTRUCTURE IN THIS VICINITY. ALL OTHER INFORMATION HEREON HAS BEEN PROVIDED BY OTHERS AND IS NOT A PART OF THIS CERTIFICATION.
- AERIAL IMAGERY SOURCE: GEOLOCATION VIA CIVIL3D.
- ONLY STRUCTURES AND INVERTS SURVEYED FOR EXISTING STORM AND SANITARY GRAVITY SYSTEMS. AS SUCH, THESE SYSTEMS ARE SHOWN AS QL-C. UTILITY RODDING NOT PART OF WORK SCOPE AND AS SUCH, THESE SYSTEMS CANNOT BE VERIFIED AS QL-B.
- ANY UTILITIES THAT FIELD CREWS DEEMED UNLOCATABLE HAVE BEEN DRAFTED ON THE QL-D LINETYPE. THEIR EXISTENCE AND LOCATION IS BASED ON RECORDS AND/OR PROFESSIONAL JUDGEMENT AND IS NOT GUARANTEED TO BE ACCURATE.
- REFERENCE CONTROL POINT: COORDINATES AND ELEVATIONS USED HEREON BASED ON CONTROL POINT #1 PROVIDED BY OLSSON. COORDINATES ARE IN STATE PLANE COLORADO CENTRAL ZONE 0502. ELLIPSOID GRS 80 AND HAVE BEEN MODIFIED TO GROUND USING THE COMBINED FACTOR 1.0002201472. ELEVATIONS AND COORDINATES REFERENCED FOR SITE REFER TO THE CONTROL NOTE VIA OLSSON.

OLSSON SHOT CONTROL POINT #1 WITH VRS THEN SET THE BASE UP ON IT AND RAN RTK INFILL, VRS LOCATION WAS VERIFIED AGAINST NGS NCAT SOLUTION HELD FOR BOTH H&V POSITION.

HORIZONTAL DATUM: SPC COLORADO CENTRAL ZONE (GROUND)
VERTICAL DATUM: NAVD88 (BASED ON GEOID88 PER OPUS SOLUTION ABOVE)

NGS:	OLSSON VALUES:	DIFFERENCE:
N	1735839.9340	
E	3155246.3720	
EL	5118.46	

THE COMBINED SCALE FACTOR OF 1.0002201472/ 0.999779901 PER THE OPUS SOLUTION WAS USED TO SCALE POINTS FROM GRID TO GROUND ABOUT CPT1.

INVERSE BETWEEN POINTS 1 & 3

GRID: 174.442

GROUND: 174.480

NAME AND DATE OF PERSON PERFORMING CONTROL WORK: JFT 2025-10-17



Engineering & Design

www.colliersengineering.com
Copyright © 2025, Colliers Engineering & Design. All Rights Reserved. This drawing and all the information contained herein is authorized for use only by the party for whom the services were contracted or to whom it is certified. This drawing may not be copied, reused, disclosed, distributed or relied upon for any other purpose without the express written consent of Colliers Engineering & Design.

REV	DATE	DESCRIPTION
1	10/1/25	ADDED WATER VALVE.
2	1/22/26	CHANGED DATUM. ADDED QL-A DATA.

811

PROTECT YOURSELF
ALL STATES REQUIRE
NOTIFICATION OF
EXCAVATORS, DESIGNERS, OR
ANY PERSON PREPARING TO
DISTURB THE EARTH'S SURFACE
ANYWHERE IN ANY STATE

FOR STATE SPECIFIC DIRECT PHONE NUMBERS
VISIT: WWW.CALL811.COM

OLSSON

SUE INVESTIGATION FOR
CITY OF THORNTON
2025 TREATED WATER
SYSTEM
IMPROVEMENTS
CITY OF THORNTON
ADAMS COUNTY
COLORADO



Colliers

Engineering & Design

DENVER
365 Inverness Pkwy.
Suite 100
Englewood, CO 80112
Phone: 303.731.6216
COLLIERS ENGINEERING & DESIGN, INC.

SCALE:	DRAWN BY:
AS SHOWN	SJB
DESIGNED BY:	REVIEWED BY:
SWW	SWW
DATE ISSUED:	PROJECT NUMBER:
9/26/25	25007025A
SHEET NAME:	

LEGEND & NOTES

DRAWING NUMBER:
2 of 3



Engineering & Design

www.colliersengineering.com

Copyright © 2025, Colliers Engineering & Design. All Rights Reserved. This drawing and all the information contained herein is authorized for use only by the party for whom the services were contracted or to whom it is certified. This drawing may not be copied, reused, disclosed, distributed or relied upon for any other purpose without the express written consent of Colliers Engineering & Design.

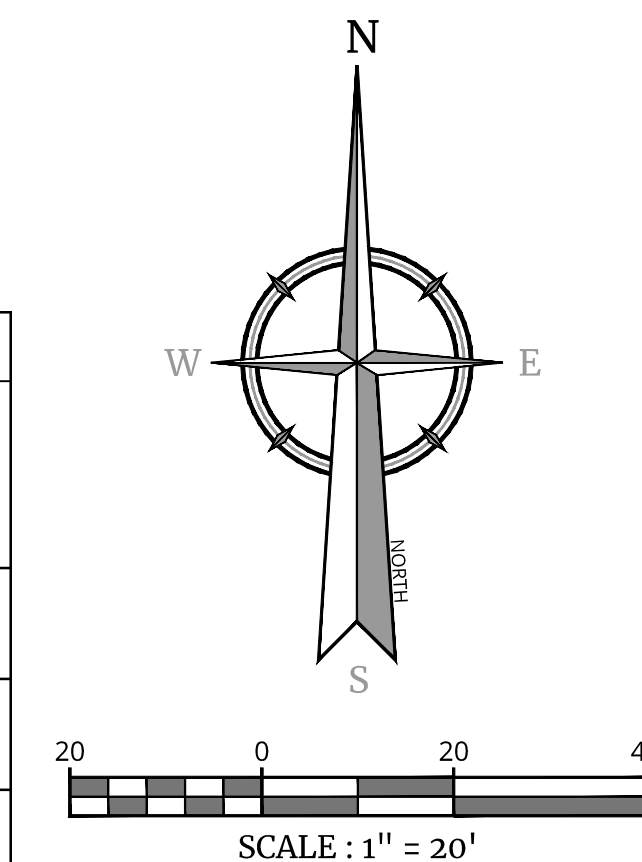

TEST HOLE #	NORTHING (FT)	EASTING (FT)	GRADE		TOP OF PIPE ELEVATION CALC. (FT)	PAVEMENT (TYPE) & DIMENSION		METHOD TO LOCATE	FEATURE DIMENSION & TYPE			GENERAL UTILITY DIRECTION	UTILITY TYPE	UTILITY OWNER	UTILITY ADDRESS/LANDMARKS/NOTES	DATE PERFORMED	ADDITIONAL COMMENTS
			ELEVATION (FT)	DEPTH (FT)		(TYPE)	(IN)		(IN)	(TYPE)							
			QL-A	(IN)		(TYPE)											
1	1735743.04	3155308.57	5116.63	3.22	5113.41	NATURAL GROUND	N/A	VACUUM EXCAVATION	8	PVC	N->S	WATER	CITY OF THORNTON	NORTH OF MADISON CT, THORNTON, CO 80229	2026-01-20	TEST HOLE COMPLETED. COULD NOT FULLY EXPOSE PIPE DUE TO COLLAPSING SOIL. SIZE PER RECORDS & VAULT OBSERVATION.	
2	1735764.61	3155308.39	5114.38	8.99	5105.39	NATURAL GROUND	N/A	VACUUM EXCAVATION	8	PVC	N->S	WATER	CITY OF THORNTON	NORTH OF MADISON CT, THORNTON, CO 80229	2026-01-20	TEST HOLE COMPLETED. COULD NOT FULLY EXPOSE PIPE DUE TO COLLAPSING SOIL. SIZE PER RECORDS & VAULT OBSERVATION.	
3	1735750.79	3155308.34	5115.12	2.58	5112.54	NATURAL GROUND	N/A	VACUUM EXCAVATION	8	PVC	N->S	WATER	CITY OF THORNTON	NORTH OF MADISON CT, THORNTON, CO 80229	2026-01-20	TEST HOLE COMPLETED. COULD NOT FULLY EXPOSE PIPE DUE TO COLLAPSING SOIL. SIZE PER RECORDS & VAULT OBSERVATION.	



REV	DATE	DESCRIPTION
1	10/1/25	ADDED WATER VAULT.
2	1/22/26	CHANGED DATUM. ADDED QL-A DATA.

811 PROTECT YOURSELF
ALL STATES REQUIRE NOTIFICATION OF EXCAVATORS, DESIGNERS, OR ANY PERSON PREPARING TO DISTURB THE EARTH'S SURFACE ANYWHERE IN ANY STATE
FOR STATE SPECIFIC DIRECT PHONE NUMBERS VISIT: WWW.CALL811.COM

OLSSON
SUE INVESTIGATION FOR
CITY OF THORNTON
2025 TREATED WATER SYSTEM IMPROVEMENTS
CITY OF THORNTON
ADAMS COUNTY
COLORADO



DENVER
365 Inverness Pkwy.
Suite 100
Englewood, CO 80112
Phone: 303.731.6216
COLLIERS ENGINEERING & DESIGN, INC.

SCALE: AS SHOWN	DRAWN BY: SJB
DESIGNED BY: SWW	REVIEWED BY: SWW
DATE ISSUED: 9/26/25	PROJECT NUMBER: 25007025A
SHEET NAME:	

UTILITIES PLAN
DRAWING NUMBER:
3 of 3

NOTE: DO NOT SCALE DRAWINGS FOR CONSTRUCTION.

C:\Users\jwhit\OneDrive\Documents\Projects\2025\25007025A\Drawings\Utilities\25007025A-UTL-01.dwg 3/1/2025 10:42:46 AM By: SWHEE188 on 2/26/25 12:46:57 PM