

- LENGTH OPTIONS
- 6' BENCH
 - 8' BENCH

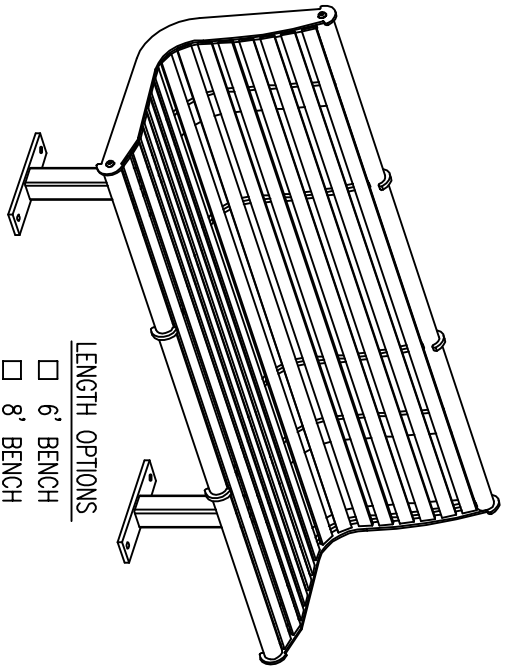

- NOTES
- 1.) ALL STL. MEMBERS COATED W/ ZINC RICH EPOXY THEN FINISHED W/ POLYESTER POWDER COATING.
 - 2.) 1/2" X 3 3/4" EXPANSION ANCHOR BOLTS PROVIDED FOR S-2, S-3 & S-4 OPTIONS.



BENCH

DATE DRAWN : 07/20/21	REV.
DRAWN BY : ESS	A
DATE REV. :	
REV. BY :	

DRAWING NUMBER

69-183SK

SHEET 1 OF 2

- NOTES:**
- 1.) DURING ASSEMBLY PROCEDURE: DO NOT COMPLETELY TIGHTEN HARDWARE.
 - 2.) THE ACTUAL PARTS WILL NOT BE NUMBERED. NUMBERS ONLY APPLY TO DRAWING.
 - 3.) UPON COMPLETION OF ASSEMBLY SQUARE ALL COMPONENTS THEN TIGHTEN ALL HARDWARE.
 - 4.) MOUNT AND ANCHOR AS SPECIFIED.

- TOOLS REQ'D**
- 3/4" WRENCH
 - 5/16" ALLEN WRENCH
 - 1/2" MASONRY DRILL BIT
 - DRILL
 - RATCHET STRAP (PROVIDED)

① ATTACH SEAT TO SUPPORTS. ATTACH END PLATES.

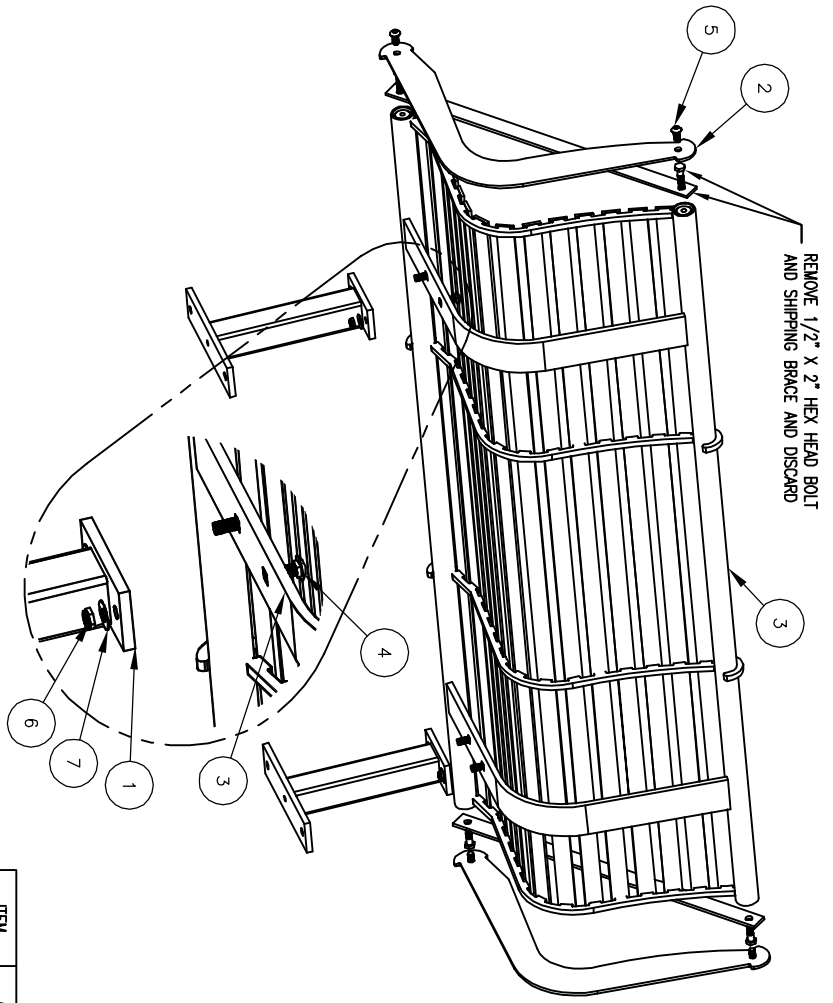

KITS PROVIDED FOR S-2

ITEM	QTY	PART NO	DESCRIPTION
8	1	K-ANCO860-4	1/2" X 3 3/4" SS ANCHOR KIT (4PC)
9	1	K-BC0816-4	1/2" CAP HARDWARE KIT (4PC)
10	1	K-CG0824-4TL	1/2" COE BOLT HARDWARE KIT (4)

PARTS LIST FOR S-2

ITEM	QTY	PART NO	DESCRIPTION
1	2	0-8611-01/S-2	BENCH SUPT FOR SURE PLATE
2	2	0-9183-03SK	STL END PLATE W/ SKATE STOP
3	1	0-9183-6-02SK	6" STL SEAT, SKATE STOP
4	4	1-11-042	1/2" X 1 1/2" SS CGE BOLT
5	4	1-12-036	1/2" X 1" SS BTN SKT HD CAP SCR
6	4	1-20-018	1/2" SS THIN NYLON LOCKNUT
7	4	1-22-015	1/2" SS FLAT WASHER



ASSEMBLY INSTRUCTIONS

DATE DRAWN : 07/20/21
 DRAWN BY : ESS
 DATE REV. :
 REV. BY :

REV. A

DRAWING NUMBER 69-183SK