

ADDENDUM NO. FIVE

**HOFFMAN WAY DRAINAGE IMPROVEMENTS
88TH AVENUE TO 90TH AVENUE**

PROJECT NO. 19-244

CITY OF THORNTON, CO

TO: Prospective Bidders and all others concerned

DATE: July 5, 2022

PURPOSE: To provide additional information and clarification to the solicitation documents for the above-referenced Project.

1. The following shall Add to and/or Modify portions of the Project Manual and Drawings for the Project-noted above.

A. The Project Manual shall be modified as follows:

a. Attached to this Addendum is the revised Bid Proposal Form to include a revised Schedule of Contract Pay Items and Pricing. Prospective Bidders should use the attached Bid Proposal form for bid submission.

i. Assumptions associated with the revised Schedule of Contract Pay Items and Pricing:

1. Item 15 (203) – Unclassified Excavation (Cut) – Cut excavation excluding required excavation for structures. This is for grading around the proposed custom area inlet and the outfall downstream of 88th Ave.
2. Item 16 (203) – Unclassified Excavation (Fill) – Fill excavation excluding required excavation for structures. This is for grading around the proposed custom area inlet and the outfall downstream of 88th Ave.
3. Item 17 (203) – Unsuitable Material – Estimate of unsuitable material for unclassified excavation and sludge line trench excluding required excavation for proposed storm sewer structures.
4. Item 18 (206) – Structure Excavation (Over-Excavation) – Estimate of special structure excavation based on 50% of trench requiring improved subgrade.
5. Item 19 (206) – Structure Backfill (Over-Excavation) – Estimate of special structure backfill based on 50% of trench requiring improved subgrade. This number excludes the required aggregate base course, where required. This is a backfill estimate for special structure excavation above the ABC prism for unshored excavation.

6. Item 36 (304) – Aggregate Base Course (Class 6) (Over-Excavation) – Estimate of aggregate base course backfill for special structure excavation and backfill.

B. The Project Documents shall be modified as follows:

- a. Attached to this Addendum are revised Contract Drawing sheets 6, 12, 55 and 56. All revisions are identified by red outlines.
- b. Attached to this Addendum is the revised Project Technical Specifications. The following sections are highlighted for Bidder's convenience.
- c. Attached to this Addendum is the document titled "Addendum to Geotechnical Engineering Study, Hoffman Way Parallel Drainage, 88th Avenue to 90th Avenue, Thornton, Colorado" dated March 4, 2021.

2. The following questions and answers are provided for additional clarification to the Contract Documents.

Question 1: "Sheet 55 shows two types of structure excavation; one for standard and one for special. There is significant cost associated with shoring and dewatering depending on which detail will be used. Given the recommendation of the soils report, it appears the special details will be used for the entire length of the project. Is this assumption correct? If not, how will it be determined when the standard or special details are needed?"

Answer 1: From general notes (No. 3) on sheet 54 of the construction documents, a representative of the geotechnical engineer shall observe the excavation and determine the need to utilize the special structure excavation requirements. Sheets 55 and 56 of the construction documents have been revised to reflect bid quantity assumptions based on the requirement to protect adjacent utilities via trench box or temporary shoring. With water table elevations varying across the site, it was assumed that 50% of the trench excavation would require special structure excavation and backfill, based on an average design groundwater level of seven feet below existing grade, as determined by the project geotechnical engineer. For bidding purposes, the contractor should use the standard structure excavation and backfill details. The additional over-excavation and backfill that may be required to achieve an increased allowable bearing pressure of 1,500 psf has been approximated in bid items 18, 19, and 36. See notes on revised sheets 6, 55, and 56.

Question 2: "The Geotech report notes the soil will likely be classified as a type C soil, which has a 1-1/2:1 slope ratio for unshored excavations. The details on sheet 55 show a 1:1 slope ratio. Were the quantities determined factoring a type C soil or the 1:1 slope ratio

shown?”

Answer 2: Quantities provided in the bid tab used the following assumptions for structural excavation and backfill.

- Standard structure excavation, backfill and shoring, is incidental to the unit price for the respective structure.
- As noted in A1, above, bid items 18, 19, and 36 are estimates for the over-excavation volume for the “Special Structure Excavation and Backfill” to assist in bidding.
- The special structure excavation and backfill earthwork estimates are based on the recommended 1:1 slope ratio for un-shored excavation, where achievable. A trench box or temporary shoring was assumed for the remaining earthwork estimate.

The details shown on Sheet 55 are standard details. However, due to site constraints, including but not limited to, utility interference, and pavement/concrete/turf restoration, the quantities assume the use of a trench box or temporary shoring for structure excavation estimates, where layback slopes are not achievable.

Question 3: “The Geotech report mentions the box culverts will likely be installed utilizing a trench box. Assuming the contractor will be utilizing a combination of trench boxes and sloping at 1-1/2:1; this will affect the quantities for pay items 19, 20 & 37. Will these pay items be remeasured in the field or not remeasured and paid based on the full bid quantity?”

Answer 3: Revised quantities have been updated (and are included in the revised Schedule of Contract Pay Items and Pricing) assuming a trench box or temporary shoring for the box culvert where layback slopes are not achievable due to the existing site constraints identified above.

Question 4: “Please clarify the 24” C900? Specs call for Class 200 which is an old C900 classification. Class 150 use to be considered DR18 and Class 200 use to be considered DR14?”

Answer 4: Either DR-25 or DR-18 may be used for the 24” C900 sludge line pipe.

Question 5: “Is there Sanitary Sewer pipe removal?”

Answer 5: The existing sanitary sewer drop manhole will need to be removed. Existing sanitary sewer pipe is to be abandoned in place. An additional manhole removal under item 202 of the bid tab sheet has been added and a revision to sheet 12 has been issued to clarify the manhole removal/replacement.

Question 6: "It appears the sludge line is a new main and we are not removing or connecting to an existing line. Is this correct?"

Answer 6: This is a new line to be used for future developments. No removals or connections are required for this line.

Question 7: "The sludge line specification section mentions unstable trench bottom and a 2' repair needed if encountered. How is the repair to be paid?"

Answer 7: Should unstable trench bottom repairs be required, they would be addressed under bid item 18, Unsuitable Material.

Question 8: "If trench stabilization is needed (i.e. ground water) for the sanitary sewer, box culverts, RCP or structures, how will this be paid?"

Answer 8: This is covered under special structure overex for the storm sewer improvements. Bid Item 18, Unsuitable Material should be used for sanitary trench stabilization.

Question 9: "Does the pay item for Muck Excavation require an imported material or can we use on site native materials?"

Answer 9: If onsite materials meet Geotech requirements, import for unsuitable materials is not required. This does not apply to the special structure overex per sheet 55.

3. This Addendum becomes part of the Contract Documents. All other conditions and requirements of the Contract Documents will remain unchanged. Receipt of this Addendum must be acknowledged in the space provided on the Bid Proposal Form in the Project Manual.

END OF ADDENDUM NO. FIVE

DocuSigned by:
Jim Jensen 7/5/2022
E037D2780399405...

Jim Jensen Date
Contracts Manager

BID PROPOSAL

To: City of Thornton
Attention: Contracts and Purchasing Director
9500 Civic Center Drive
Thornton, Colorado 80229

The undersigned Bidder, having examined the Specifications, Drawings, and all other documents contained in the Contract Documents, and having examined the Project site where the Work is to be performed, and having familiarized itself with all local conditions affecting the Work and having knowledge of the cost of Work, hereby proposes to execute and perform the Contract set forth in these Contract Documents, of which this Bid Proposal forms a part, and shall do the Work therein described in accordance with the terms and conditions therein set forth, and shall furnish all required labor, Materials, Equipment, tools, Construction Equipment, transportation and services for said Work, and shall pay all applicable fees, permits, taxes, and other incidental costs, all in strict conformity with the Contract Documents, for an amount computed upon the basis of the quantity of Work actually performed at the Bid Proposal prices provided below.

It is understood that any listed quantities of Work to be performed at Unit Prices, except those items specified to be paid at plan quantity, are approximate only and are intended principally to serve as a guide in evaluating Bid Proposals, and the Work will be paid by measuring actual quantities and multiplying the actual quantity by the agreed upon Unit Price. Listed quantities of Work specified to be paid at plan quantity are given as a convenience to assist the Bidder during the bid process and are approximate only, and both Bidder and Thornton agree that regardless of the actual final in place quantity the items of Work specified to be paid at plan quantities will not be measured for payment, and payment will be made based on the plan quantity specified multiplied by the agreed upon Unit Price.

It is further agreed that any quantities of Work to be performed and Material to be furnished at Unit Prices may be increased or decreased as may be considered necessary, in the opinion of Thornton, to complete the Work fully as planned and contemplated and that all quantities of Work or Materials, whether increased or decreased, are to be performed at the Unit Prices set forth in the Bid Proposal, except as provided for in the General Conditions.

It is further agreed that any Lump Sum Prices may be increased to cover Changed or Extra Work ordered by Thornton, but not shown on the Drawings or required by the Specifications, in accordance with the provisions of the General Conditions. Similarly, they may be decreased to cover deletion of Work so ordered.

It is further agreed that any combination of Unit Prices and Lump Sum Prices contained in the Bid Proposal, as applicable, may be used by Thornton to price Changed or Extra Work regardless of the scope or quantity of the change, except as may be otherwise provided for in the General Conditions.

By submitting this Bid Proposal, the Bidder acknowledges its understanding that the Bid process is solely intended to serve the public interest, in achieving the highest quality of

services and goods at the lowest price and that no right, interest, or expectation shall vest or inure to the benefit of a Bidder as a result of any reliance or participation in the process. In submitting this Bid Proposal, it is understood that the right is reserved by Thornton to reject any or all Bid Proposals and waive informalities or irregularities in Bid Proposals.

The undersigned further agrees, if awarded the Contract for the Work included in this Bid Proposal, to begin and to complete the Work contemplated in accordance with all the conditions set forth in the Contract Documents.

The undersigned has carefully checked the Unit Prices, Lump Sum Prices, and Extended Prices inserted by it and understands that they are the Bidder's sole responsibility and that Thornton will not be responsible for any errors or omissions on the part of the undersigned Bidder in preparing this Bid Proposal.

The undersigned certifies that this Bid Proposal is genuine, not collusive, or made in the interest or behalf of any person not named as provided in the Instruction to Bidders and that the undersigned has not, directly or indirectly, induced or solicited any other Bidder, or induced any other person, firm or corporation to refrain from submitting a Bid Proposal, and the undersigned has not in any manner sought by collusion to secure for itself an advantage over any other Bidder.

The undersigned has attached a certified check without endorsement or conditions, payable to the City of Thornton, in the sum of five percent (5%) of the Bid Proposal, drawn on a bank which is a member of Federal Reserve System or which is a member of the Federal Deposit Insurance Corporation, or attach a cashier's check for five percent (5%) of the total Bid Proposal amount, or attach a Bid Bond written by a surety company approved by Thornton and listed in the most recent Federal Register Circular 570 or having a current Best's rating of A or better for five percent (5%) of the total Bid Proposal amount.

It is expressly understood that the check or bond is given as security and as a guarantee that the Bidder will, if awarded the Contract, timely execute the Contract, furnish an acceptable Performance Bond and Labor and Material Payment Bond on the forms included in the Contract Documents if required, furnish the required insurance, and furnish the other documents required by the Contract. The undersigned expressly acknowledges that the amount thereof represents the agreed damages that Thornton will sustain if the Bidder fails or refuses to execute and deliver within ten (10) Calendar Days from and including the date of the Notice of Award, the Contract, the required Performance Bond and Labor and Material Payment Bond, the required insurance, and the other documents required by the Contract, in which event said check or bond shall be immediately payable to and retained by Thornton.

The Bidder grants Thornton the right to hold the lowest three (3) Bid Proposals received, together with the accompanying Bid Proposal securities, for a period of sixty (60) Calendar Days after the date of submission of the Bid Proposals and to delay Notice of Award until the end of such time period.

The undersigned Bidder further grants Thornton the right to award this Contract on the basis of any possible combinations of base Bid Proposal and add or deduct alternate(s), if any, that best suits Thornton's needs.

The undersigned Bidder further agrees to comply with Colorado's statutes. Pursuant to Colorado law, if Bidder's form of business is a sole proprietor or individual, Bidder hereby agrees that upon receipt of Notice of Award, Bidder will complete and file with Thornton a sworn Affidavit, the form of which will be provided by Thornton, affirming that Bidder is lawfully present in the United States and to provide acceptable identification as described in the Affidavit. Furthermore, if Bidder's Work involves provision of a service and not provision of a specific end product, Bidder, upon being awarded the Work, hereby certifies the following:

1. Bidder, as of the date of Notice of Award, does not and shall not knowingly employ or contract with a worker without authorization, who will perform Work under this Contract.
2. Bidder shall participate in either the Employment Verification Program (E-Verify Program) created in Public Law 104-208, as amended and expanded in Public Law 108-156, as amended, and jointly administered by the United States Department of Homeland Security and the Social Security Administration, or its successor program, or the Department Program, which is the employment verification program established by the Colorado Department of Labor and Employment (the "Department") pursuant to C.R.S. §§ 8-17.5-102(5)(c) in order to confirm the employment eligibility of all employees who are newly hired for employment to perform work under the Agreement.
3. Bidder has confirmed the employment eligibility of all employees who are newly hired for employment to perform Work under the Contract through participation in either the E-Verify Program or the Department Program.
4. Bidder shall not enter into a contract with a Subcontractor that fails to certify to Bidder that the Subcontractor shall not knowingly employ or contract with a worker without authorization, to perform Work under this Contract.
5. Bidder shall not use either the E-Verify Program or the Department Program procedures to undertake pre-employment screening of job applicants while this Contract is being performed.
6. If Bidder obtains actual knowledge that a Subcontractor performing Work under this Contract employs or contracts with a worker without authorization, Bidder shall:
 - a. Notify the Subcontractor and Thornton within three (3) Calendar Days that Bidder has actual knowledge that the Subcontractor is employing or contracting with a worker without authorization; and

- b. Terminate the subcontract with the Subcontractor if within three (3) Calendar Days of receiving the notice required pursuant to this subparagraph, the Subcontractor does not stop employing or contracting with a worker without authorization; except that Bidder shall not terminate the subcontract with the Subcontractor if during such three (3) Calendar Days the Subcontractor provides information to establish that the Subcontractor has not knowingly employed or contracted with a worker without authorization.
- 7. Bidder shall comply with any reasonable request by the Colorado Department of Labor and Employment made in the course of an investigation that the Department is undertaking pursuant to the authority established by C.R.S. § 8-17.5-102(5).
- 8. If Bidder violates any provision of this certification, Thornton may terminate this Contract for breach of Contract. If this Contract is so terminated, Contractor shall be liable for actual and consequential damages suffered by Thornton.

The Bidder's attention is directed to the fact that all applicable state and federal laws, county and city ordinances, licenses and regulations of all authorities having jurisdiction over the Project shall apply to the Contract throughout, and they will be deemed to be included in the Contract the same as though herein written out in full.

The undersigned Bidder acknowledges that the City of Thornton Charter Section 7.4 prohibits Thornton from making Contracts with firms which employ certain relatives of Thornton employees unless the City Council determines that the making of such a Contract is in Thornton's best interest. For the purposes of this Charter Section, relative shall include domestic partners. The undersigned Bidder attests to the following:

No City Council Member, member of a board or commission, Municipal Judge, City Manager, City Attorney, or employee of the City of Thornton or any such person's family member, domestic partner, or person assuming a relationship being the substantial equivalent of the above, has an existing or pending, direct or indirect, financial, pecuniary or personal interest in the Bidder or with this Invitation for Bid Proposals, except as follows (list, if none state "None"): _____

The undersigned Bidder acknowledges the following Addenda (if none, so state):

Addendum #	Dated	Initial
One	6/03/2022	
Two	6/15/2022	
Three	6/15/2022	
Four	6/24/2022	
Five	7/05/2022	

The undersigned Bidder expressly agrees to the following provisions:

- A. That the Bid Proposal stated shall include the utilization of the Subcontractor(s) and Supplier(s) listed in the List of Subcontractors/Suppliers below.
- B. That the Subcontractor(s) and Supplier(s) listed below shall not be changed by the Bidder unless the Subcontractor(s) or Supplier(s) are unable to perform due to bankruptcy, labor strikes, or termination of business by the Subcontractor(s) or Supplier(s).
- C. That any Subcontractor(s) and Supplier(s) shall be subject to Thornton’s approval.

List below any Subcontractor(s) and Supplier(s) whose contract(s) exceeds ten thousand dollars (\$10,000).

	SUBCONTRACTOR/SUPPLIER	TYPE OF WORK
1.		
2.		
3.		
4.		
5.		
6.		
7.		
8.		
9.		
10.		

Attach additional sheet if more space is needed.

**SCHEDULE OF CONTRACT PAY ITEMS AND PRICES
HOFFMAN WAY DRAINAGE IMPROVEMENTS
PROJECT NO. 19-244**

No.	Ref No.	Description	Unit	Qty	Unit Price	Cost
HOFFMAN WAY DRAINAGE IMPROVEMENTS						
1	106	TESTING AND QUALITY CONTROL	LS	1	\$	\$
2	201	CLEARING AND GRUBBING	AC	0.3	\$	\$
3	202	REMOVE AND REPLACE ASPHALT	SY	889	\$	\$
4	202	REMOVE ASPHALT AND REPLACE W/ CONCRETE	SY	67	\$	\$
5	202	REMOVE AND REPLACE CURB AND GUTTER	LF	798	\$	\$
6	202	REMOVE AND REPLACE CONCRETE	SF	246	\$	\$
7	202	REMOVE UNSUITABLE MATERIAL	CY	0	\$	\$
8	202	STORM REMOVAL	LF	240	\$	\$
9	202	15' TYPE-R INLET REMOVAL	EA	1	\$	\$
10	202	30' TYPE-R INLET REMOVAL	EA	1	\$	\$
11	202	CUSTOM AREA INLET REMOVAL	EA	1	\$	\$
12	202	MANHOLE REMOVAL	EA	1	\$	\$
13	202	TREE REMOVAL	EA	8	\$	\$
14	202	SHRUB REMOVAL	EA	22	\$	\$
15	202	REMOVE AND REPLACE SIGN	EA	2	\$	\$
16	203	UNCLASSIFIED EXCAVATION (CUT)	CY	56	\$	\$
17	203	UNCLASSIFIED EXCAVATION (FILL)	CY	382	\$	\$
18	203	UNSUITABLE MATERIAL	CY	513	\$	\$
19	206	STRUCTURE EXCAVATION (OVEREXCAVATION)	CY	2,172	\$	\$
20	206	STRUCTURE BACKFILL (OVEREXCAVATION)	CY	892	\$	\$
21	207	STOCKPILE TOPSOIL	CY	250	\$	\$
22	208	STABILIZED STAGING AREA	EA	1	\$	\$
23	208	SILT FENCE	LF	779	\$	\$
24	208	INLET PROTECTION	EA	10	\$	\$
25	208	VEHICLE TRACKING CONTROL	EA	2	\$	\$
26	208	CONCRETE WASHOUT	EA	1	\$	\$
27	208	ROCK CHECK DAM	EA	1	\$	\$
28	208	ROCK SOCK	EA	13	\$	\$
29	208	1 YEAR BMP MAINTENANCE (SOUTH OF 88TH AVENUE)	LS	1	\$	\$
30	212	REPAIR LANDSCAPE (SOD)	SF	13,867	\$	\$
31	212	NATIVE SEED AT OUTFALL	SF	4,910	\$	\$
32	213	REPAIR LANDSCAPE (MULCH)	SF	4,910	\$	\$
33	214	NEW TREES-2" CAL.	EA	7	\$	\$
34	214	NEW SHRUBS	EA	41	\$	\$
35	214	WINTER WATERINGS	EA	5	\$	\$
36	250	DEWATERING	LS	1	\$	\$
37	304	AGGREGATE BASE COURSE (CLASS 6) (OVER EXCAVATION)	CY	1,469	\$	\$
38	506	SOIL RIPRAP, TYPE-M	CY	100	\$	\$

No.	Ref No.	Description	Unit	Qty	Unit Price	Cost
39	514	PEDESTRIAN RAILING	LF	72	\$	\$
40	601	CONCRETE HEADWALL/WINGWALL	EA	1	\$	\$
41	603	5 FOOT X 7 FOOT CONCRETE BOX CULVERT (PRECAST)	LF	430	\$	\$
42	603	5 FOOT X 16 FOOT CONCRETE BOX CULVERT (PRECAST)	LF	84	\$	\$
43	603	8" SANITARY ENCASEMENT (STEEL)	LF	17	\$	\$
44	603	SANITARY BYPASS PUMPING	LS	1	\$	\$
45	604	INLET, TYPE-R SPECIAL L5	EA	2	\$	\$
46	604	INLET, TYPE-R SPECIAL L15	EA	3	\$	\$
47	604	INLET, TYPE-R L15	EA	2	\$	\$
48	604	INLET, TYPE-R SPECIAL L30	EA	1	\$	\$
49	604	INLET SPECIAL	EA	1	\$	\$
50	604	MANHOLE BOX BASE SPECIAL	EA	1	\$	\$
51	604	SANITARY DROP MANHOLE	EA	1	\$	\$
52	623	IRRIGATION RESTORATION	SF	20,000	\$	\$
53	624	15" RCP (CLASS III)	LF	23	\$	\$
54	624	18" RCP (CLASS III)	LF	14	\$	\$
55	624	24" RCP (CLASS III)	LF	23	\$	\$
56	624	36" RCP (CLASS III)	LF	14	\$	\$
57	624	72" RCP (CLASS III)	LF	23	\$	\$
58	624	8" PVC (SDR 35)	LF	80	\$	\$
59	625	CONSTRUCTION SURVEYING	L S	1	\$	\$
60	626	MOBILIZATION	L S	1	\$	\$
61	627	PAVEMENT MARKINGS	LS	1	\$	\$
62	630	TRAFFIC CONTROL	LS	1	\$	\$
63	NA	BONDS AND INSURANCE (TOTAL FOR ENTIRE PROJECT)	LS	1	\$	\$
HOFFMAN WAY DRAINAGE SUBTOTAL						\$

HOFFMAN WAY SLUDGE LINE						
64	106	TESTING AND QUALITY CONTROL	LS	1	\$	\$
65	202	REMOVE AND REPLACE ASPHALT	SY	314	\$	\$
66	202	REMOVE AND REPLACE CURB & GUTTER	LF	357	\$	\$
67	208	EROSION CONTROL	LS	1	\$	\$
68	604	24 INCH PVC (UNRESTRAINED)	EA	566	\$	\$
69	624	24 INCH PVC (RESTRAINED)	LF	128	\$	\$
70	625	CONSTRUCTION SURVEYING	LS	1	\$	\$
71	626	MOBILIZATION	LS	1	\$	\$
72	627	PAVEMENT MARKINGS	LS	1	\$	\$
73	630	TRAFFIC CONTROL	LS	1	\$	\$
HOFFMAN WAY SLUDGE LINE SUBTOTAL						\$

HOFFMAN WAY DRAINAGE AND SLUDGE LINE TOTAL BID \$

Due to the difficulty with estimating the quantity for those Pay Items Quantities noted with an *, the Bidders should assume that the final quantity for these Pay Items may vary by more than plus or minus twenty-five percent (25%) of the estimated quantity indicated. Unit Prices for such Pay Items are not subject to renegotiation regardless of the amount by which the actual quantity finally installed is above or below the estimated quantity indicated in the Bid Proposal form.

Indicate if you are claiming eligibility for Local Vendor Consideration by checking below, and if so, supply the required documentation.

Yes, Bidder claims eligibility for Local Vendor Consideration.

No, Bidder does not claim eligibility for Local Vendor Consideration.

SCHEDULE OF CONTRACT ITEMS AND PRICES

Total Bid Proposal _____ Dollars
(Words)

_____ Cents
(Words)

\$ _____
(Numerals)

Dated this _____ day of _____, 20__.

Firm Name: _____

Authorized Signer (Print Name): _____

Signature: _____

Title: _____

Email : _____

Bidder's Legal Status: _____

State of Organization: _____

Firm's Address: _____

Telephone: _____

For the Individual who will Attest Contract if Awarded:

Name: _____

Title: _____

Email: _____

Bid Proposal Witness: (Attest and Seal if Bid Proposal is by Corporation)

THIS PAGE INTENTIONALLY LEFT BLANK

REFERENCE AUTHORIZATION AND RELEASE FORM

By: _____, A Corporation
 _____, A Partnership whose address is:
 _____, An Individual
 (Proposing firm)

Proposing Firm has submitted a sealed proposal to the City of Thornton (Thornton) for engineering services for the Hoffman Way Drainage Improvements – 88th Avenue to 90th Avenue, Project No. 19-244 (Project).

Proposing Firm hereby authorizes Thornton to perform such investigation of proposing firm as it deems necessary to verify the qualifications, responsibility, trustworthiness and financial ability of Proposing Firm. By its signature hereon, the proposing firm authorizes Thornton to obtain reference information concerning the proposing firm. Proposing Firm further agrees to release and hold Thornton and the firm or agency providing reference information harmless from all liability resulting from providing the requested reference information to Thornton about the Proposing Firm.

Proposing Firm further authorizes Thornton to discuss and release reference information regarding Proposing Firm’s performance as it will relate to this upcoming Project upon receiving a request for such information. Proposing Firm agrees to release and hold Thornton harmless from all liability associated with releasing such information about Proposing Firm.

Proposing Firm further waives its right to receive copies of reference information provided to Thornton. By signing below, Proposing Firm agrees with the terms of this Reference Authorization and Release and authorizes Thornton to obtain reference information concerning Proposing Firm.

A copy or facsimile of this executed Reference Authorization and Release Form may be used with the same effectiveness as an original.

 Signature Date

 Print Name

 Title

STORM IMPROVEMENTS SUMMARY OF APPROXIMATE QUANTITIES

ITEM NO.	DESCRIPTION	UNIT	STORM IMPROVEMENTS		EROSION CONTROL		TOTAL	
			PLAN	AS CONST.	PLAN	AS CONST.	PLAN	AS CONST.
106	TESTING AND QUALITY CONTROL	LS	1				1.0	
201	CLEARING AND GRUBBING	AC	0.3				0.3	
202	REMOVE AND REPLACE ASPHALT	SY	1,203				1,203	
202	REMOVE ASPHALT AND REPLACE W/ CONCRETE	SY	67				67	
202	REMOVE AND REPLACE CONCRETE	SY	246				246	
202	REMOVE AND REPLACE CURB AND GUTTER	LF	1,155				1,155	
202	STORM REMOVAL	LF	240				240	
202	15' TYPE-R INLET REMOVAL	EA	1				1	
202	30' TYPE-R INLET REMOVAL	EA	1				1	
202	CUSTOM AREA INLET REMOVAL	EA	1				1	
202	MANHOLE REMOVAL	EA	2				2	
202	TREE REMOVAL	EA	8				8	
202	SHRUB REMOVAL	EA	22				22	
202	REMOVE AND REPLACE SIGN	EA	2				2	
203	EARTHWORK (CUT)	CY	56				56	
203	EARTHWORK (FILL)	CY	282				282	
203	UNSUITABLE MATERIALS	CY	513				513	
206	STRUCTURE EXCAVATION (OVEREXCAVATION)	CY	2,172				2,172	
206	STRUCTURE BACKFILL (OVEREXCAVATION)	CY	892				892	
207	STOCKPILE TOPSOIL	CY	250				250	
208	STABILIZED STAGING	EA			1		1	
208	SILT FENCE	LF			779		779	
208	INLET PROTECTION	EA			10		10	
208	VEHICLE TRACKING CONTROL	EA			2		2	
208	CONCRETE WASHOUT	EA			1		1	
208	ROCK SOCK	EA			13		13	
208	ROCK CHECK DAM	EA			1		1	
208	1 YEAR BMP MAINTENANCE (SOUTH OF 88TH AVENUE)	LS			1		1	
212	REPAIR LANDSCAPE (SOD)	SF			13,867		13,867	
212	NATIVE SEED AT OUTFALL	SF			4,910		4,910	
213	REPAIR LANDSCAPE (MULCH)	SF			4,910		4,910	
214	NEW TREES-2" CAL.	EA	7				7	
214	NEW SHRUBS	EA	41				41	
214	WINTER WATERINGS	EA	5				5	
250	DEWATERING	LS	1				1	
304	AGGREGATE BASE COURSE (CLASS 6) (OVER EXCAVATION)	CY	1,469				1,050	
506	SOIL REPAIR, TYPE M	LY	108				108	
514	PEDESTRIAN RAILING	LF	72				72	
601	CONCRETE HEADWALL/WINGWALL	EA	1				1	
603	5 FOOT X 7 FOOT CONCRETE BOX CULVERT (PRECAST)	LF	430				430	
603	5 FOOT X 16 FOOT CONCRETE BOX CULVERT (PRECAST)	LF	84				84	
603	8" SANITARY ENCASEMENT (STEEL)	LF	17				17	
603	SANITARY BYPASS PUMPING	LS	1				1	
604	INLET, TYPE-R SPECIAL L5	EA	2				2	
604	INLET, TYPE-R SPECIAL L15	EA	3				3	
604	INLET, TYPE-R L15	EA	2				2	
604	INLET, TYPE-R SPECIAL L30	EA	1				1	
604	INLET SPECIAL	EA	1				1	
604	MANHOLE BOX BASE SPECIAL	EA	1				1	
604	SANITARY DROP MANHOLE	EA	1				1	
619	24" PVC (C900) RESTRAINED	LF	128				128	
619	24" PVC (C900) UNRESTRAINED	LF	566				566	
623	IRRIGATION RESTORATION	SF	20,000				20,000	
624	15" RCP (CLASS III)	LF	23				23	
624	18" RCP (CLASS III)	LF	14				14	
624	24" RCP (CLASS III)	LF	23				23	
624	36" RCP (CLASS III)	LF	14				14	
624	72" RCP (CLASS III)	LF	23				23	
624	8" PVC (SDR 35)	LF	80				80	
625	CONSTRUCTION SURVEYING	LS	1				1	
626	MOBILIZATION	LS	1				1	
627	PAVEMENT MARKINGS	SF	170				170	
630	TRAFFIC CONTROL	LS	1				1	

2

2

2

2 **EARTHWORK DISCLAIMER:**
EARTHWORK QUANTITIES ARE RAW NUMBERS AND HAVE NOT BEEN ADJUSTED TO ACCOUNT FOR SHRINK, SWELL, COMPACTION, PAVING, UTILITY SPOILS, ETC. IN ADDITION, SHORING HAS BEEN ASSUMED IN THE EARTHWORK QUANTITIES PROVIDED. IT IS THE CONTRACTORS RESPONSIBILITY TO VERIFY ALL EARTHWORK AND SHORING REQUIREMENTS BASED ON PROPOSED MEANS AND METHODS. PER THE PROJECT MANUAL, ALL EARTHWORK SHALL BE PAID AT BID QUANTITIES UNLESS A CHANGE IS SUBSTANTIATED THROUGH A CHANGE ORDER.

Print Date: _____
 File Name: SUMMARY OF APPROXIMATE QUANTITIES.dwg
 Horiz. Scale: _____ Vert. Scale: _____
 Unit Information: _____ Unit Leader: _____



12499 WEST COLFAX AVENUE,
LAKEWOOD, COLORADO 80215
MAIN 303.431.6100
MARTINMARTIN.COM

Sheet Revisions		
Date	Comments	Init.
04-01-22	FOR BID	M/M
06-29-22	REISSUE SHEETS 6 & 12	M/M



No Revisions:	
Revised:	
Void:	

HOFFMAN WAY
DRAINAGE IMPROVEMENTS
SUMMARY OF APPROX QUANTITIES

Designer: R. BYRNE
 Detailer: E. BEDNAR
 Sheet Subset: ----- Subset Sheet: -----

Project No./Code	19.1187
FINAL DESIGN	
SHEET NO.	06

LOCATION	Pavement Section Thicknesses (inches)	
	Full-Depth Hot Mix Asphalt	Hot Mix Asphalt over Aggregate Base Course
East 88 th Avenue	13.0	9 over 16
Hoffman Way	8.5	6 over 10

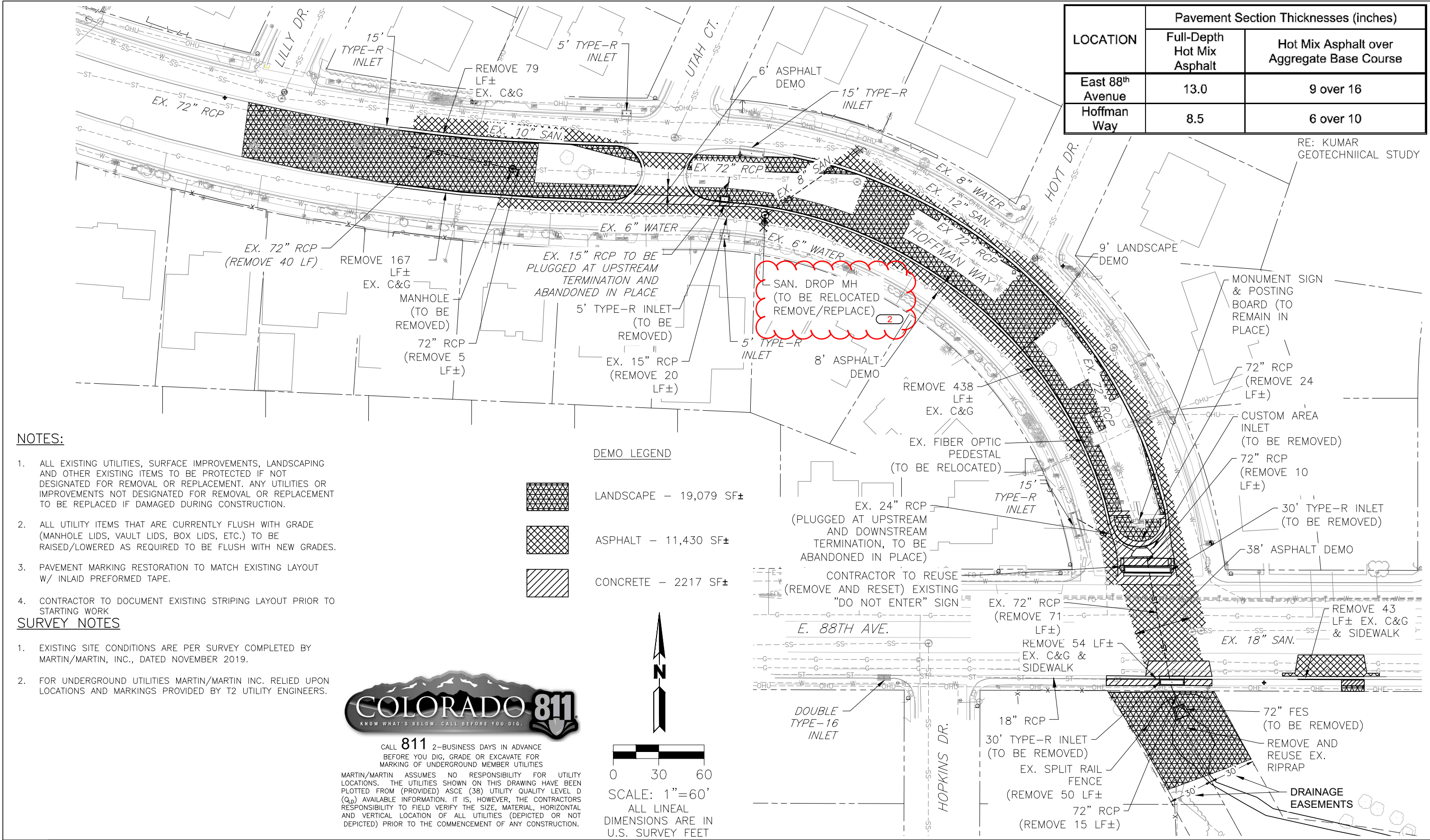

RE: KUMAR GEOTECHNICAL STUDY

NOTES:

- ALL EXISTING UTILITIES, SURFACE IMPROVEMENTS, LANDSCAPING AND OTHER EXISTING ITEMS TO BE PROTECTED IF NOT DESIGNATED FOR REMOVAL OR REPLACEMENT. ANY UTILITIES OR IMPROVEMENTS NOT DESIGNATED FOR REMOVAL OR REPLACEMENT TO BE REPLACED IF DAMAGED DURING CONSTRUCTION.
- ALL UTILITY ITEMS THAT ARE CURRENTLY FLUSH WITH GRADE (MANHOLE LIDS, VAULT LIDS, BOX LIDS, ETC.) TO BE RAISED/LOWERED AS REQUIRED TO BE FLUSH WITH NEW GRADES.
- PAVEMENT MARKING RESTORATION TO MATCH EXISTING LAYOUT W/ INLAID PREFORMED TAPE.
- CONTRACTOR TO DOCUMENT EXISTING STRIPING LAYOUT PRIOR TO STARTING WORK

SURVEY NOTES

- EXISTING SITE CONDITIONS ARE PER SURVEY COMPLETED BY MARTIN/MARTIN, INC., DATED NOVEMBER 2019.
- FOR UNDERGROUND UTILITIES MARTIN/MARTIN INC. RELIED UPON LOCATIONS AND MARKINGS PROVIDED BY T2 UTILITY ENGINEERS.



CALL 811 2-BUSINESS DAYS IN ADVANCE BEFORE YOU DIG, GRADE OR EXCAVATE FOR MARKING OF UNDERGROUND MEMBER UTILITIES
 MARTIN/MARTIN ASSUMES NO RESPONSIBILITY FOR UTILITY LOCATIONS. THE UTILITIES SHOWN ON THIS DRAWING HAVE BEEN PLOTTED FROM (PROVIDED) ASCE (38) UTILITY QUALITY LEVEL D (Q_u) AVAILABLE INFORMATION. IT IS, HOWEVER, THE CONTRACTORS RESPONSIBILITY TO FIELD VERIFY THE SIZE, MATERIAL, HORIZONTAL AND VERTICAL LOCATION OF ALL UTILITIES (DEPICTED OR NOT DEPICTED) PRIOR TO THE COMMENCEMENT OF ANY CONSTRUCTION.

DEMO LEGEND

	LANDSCAPE - 19,079 SF±
	ASPHALT - 11,430 SF±
	CONCRETE - 2,217 SF±

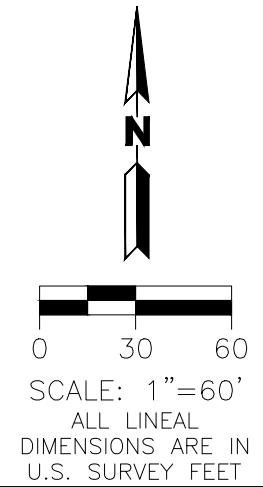

Print Date:	
File Name: DEMO PLAN.dwg	
Horiz. Scale:	Vert. Scale:
Unit Information	Unit Leader
	12499 WEST COLFAX AVENUE, LAKEWOOD, COLORADO 80215 MAIN 303.431.6100 MARTINMARTIN.COM

Sheet Revisions		
Date:	Comments	Init.
04-01-22	FOR BID	M/M
06-29-22	BID ADDENDUM	M/M



No Revisions:	
Revised:	
Void:	

HOFFMAN WAY DRAINAGE IMPROVEMENTS DEMOLITION PLAN	
Designer:	R. BYRNE
Detailer:	E. BEDNAR
Sheet Subset:	--- Subset Sheet:

Project No./Code	19.1187
	FINAL DESIGN
SHEET NO.	12

PLOT DATE: Wednesday, June 29, 2022 12:18 PM LAST SAVED BY: MGEIGER
DRAWING LOCATION: G:\HORN\19.1187-Hoffman Way - Parallel Drainage System\PLANS\STRUCT\55 SPECIAL STRUCTURE EXCAVATION AND STRUCTURE BACKFILL DETAILS.dwg 55 STRUCTURE EXCAVATION AND STRUCTURE BACKFILL DETAILS

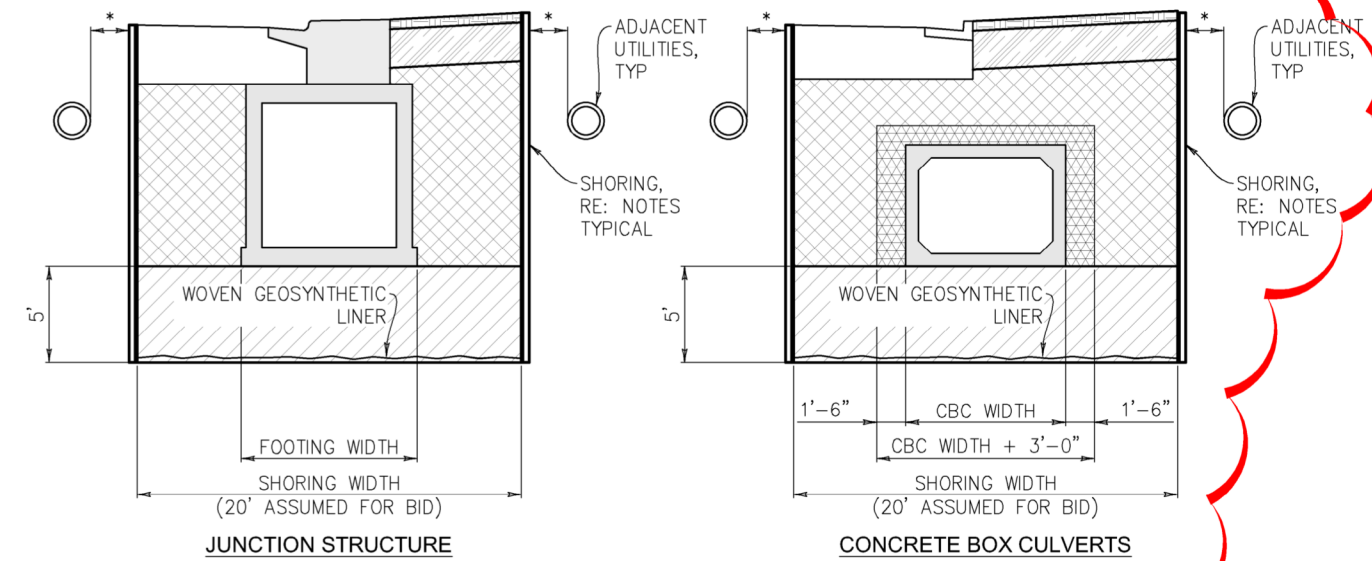
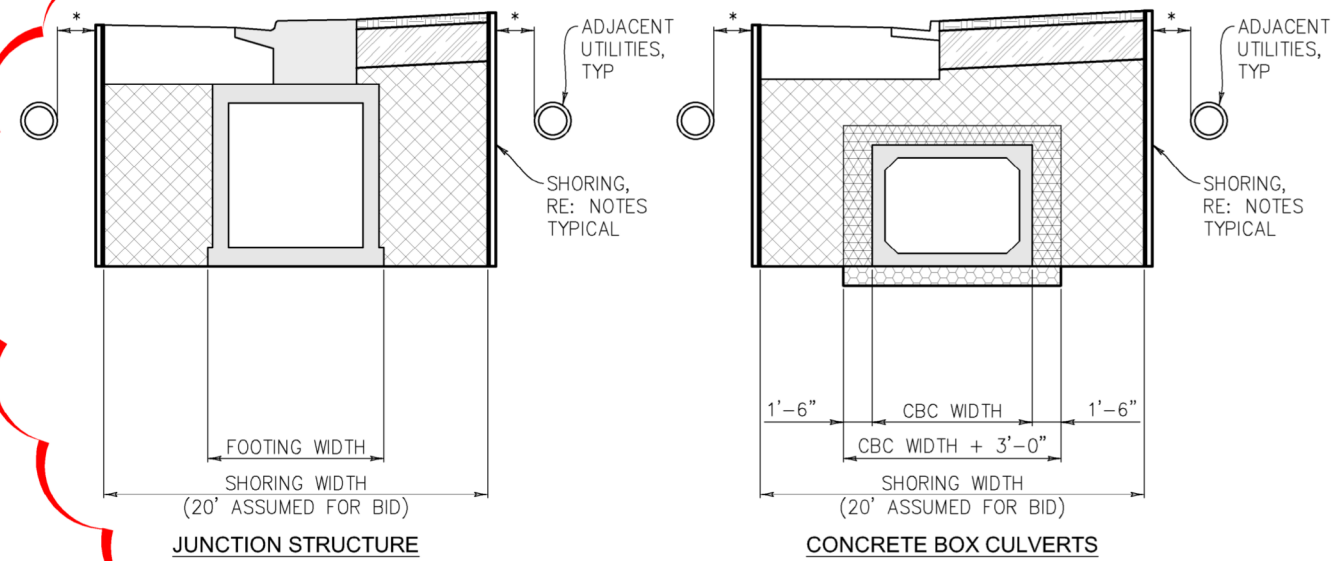
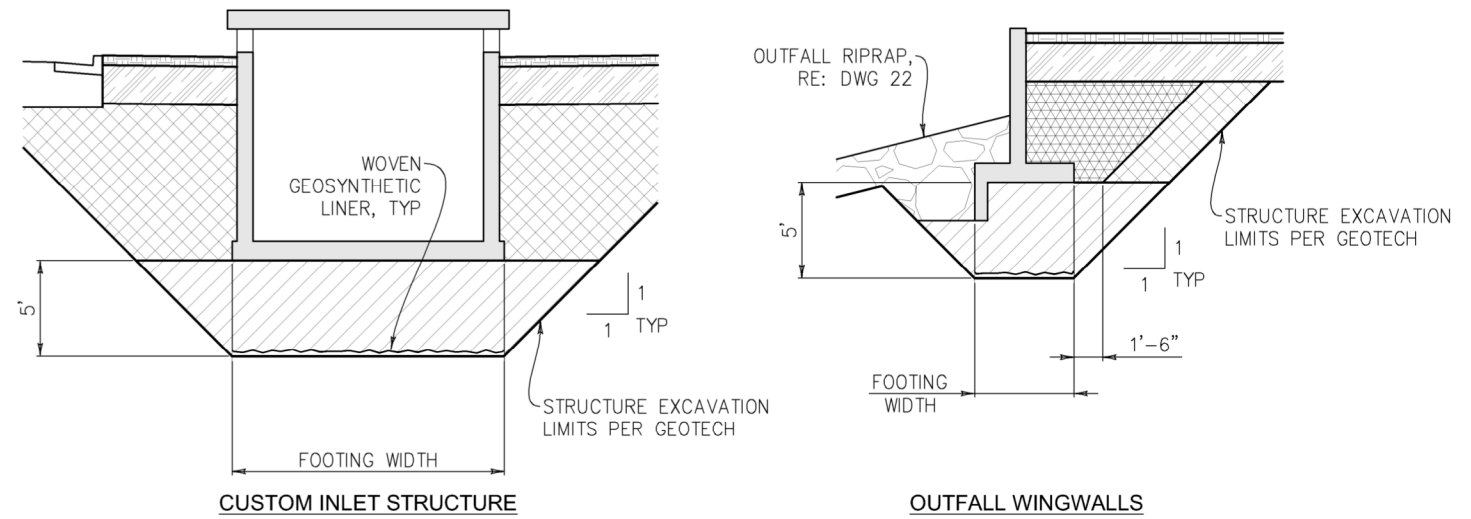
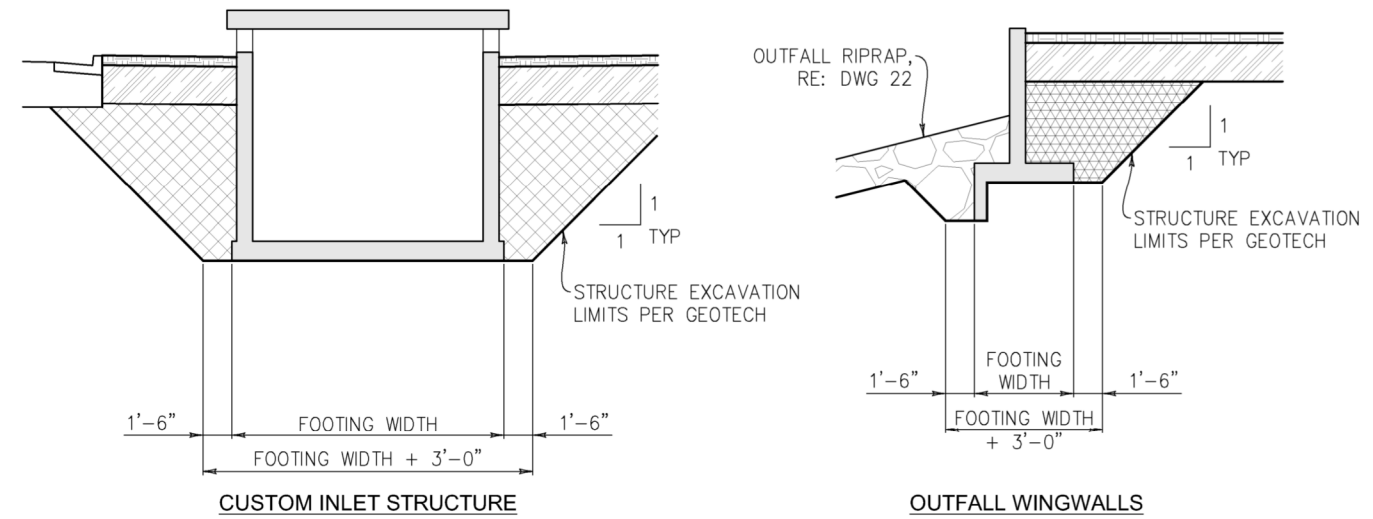

STANDARD STRUCTURE EXCAVATION AND STRUCTURE BACKFILL DETAILS

NOTE:
 COST FOR SHORING, STANDARD STRUCTURE EXCAVATION, AND STRUCTURE BACKFILL SHALL BE INCLUDED IN ITEMS 601, 603 AND 604 FOR EACH STRUCTURE.

SPECIAL STRUCTURE EXCAVATION AND STRUCTURE BACKFILL DETAILS

NOTES:

- COST FOR SHORING, ADDITIONAL SPECIAL STRUCTURE EXCAVATION, AND STRUCTURE BACKFILL OVER AND ABOVE THE STANDARD STRUCTURE EXCAVATION AND STRUCTURE BACKFILL SHALL BE PAID FOR SEPARATELY UNDER THE ITEMS 206 STRUCTURE EXCAVATION (OVEREXCAVATION) AND 206 STRUCTURE BACKFILL (OVEREXCAVATION).
- WOVEN GEOSYNTHETIC LINER SHALL BE MIRAFI RS580i OR GEOTECHNICAL APPROVED EQUAL. COST FOR WOVEN GEOSYNTHETIC LINER SHALL BE INCLUDED IN THE COST FOR ITEM 304 AGGREGATE BASE COURSE (CLASS 6) (OVEREXCAVATION).

2 TYPICAL SHORING NOTES:

- SHORING PROVIDED BY CONTRACTOR. LOCATION AND EXTENTS OF SHORING IS A MEANS AND METHODS FOR CONSTRUCTION. SHORING SHOWN FOR BID PURPOSES ONLY. SHORING LOCATION ASSUMPTIONS FOR BIDDING ARE INDICATED ON SHEET NO 56. SHORING SYSTEM TO PROVIDE TEMPORARY SUPPORT FOR EXISTING UTILITIES DURING CONSTRUCTION. CONTRACTOR OPTION TO PROVIDE ALTERNATE UTILITY SUPPORT, PROVIDED UTILITY SERVICES ARE NOT INTERRUPTED, DAMAGED, OR DISTURBED.
- THE MAXIMUM SHORING DIMENSION TO BE VERIFIED IN FIELD AND CONFIRMED TO MAINTAIN AT LEAST 2'-0" OFFSET FROM UTILITIES (AS NOTED THUS "**") OR MINIMUM OFFSET REQUIRED BY UTILITY COMPANY, WHICHEVER IS GREATER.

LEGEND

	6" TOPSOIL (TO BE PAID FOR AS PART OF LANDSCAPING)		CDOT STRUCTURE BACKFILL (CLASS 1)
	IMPERMEABLE MATERIAL (2' MINIMUM)		CDOT STRUCTURE BACKFILL (CLASS 6 AGGREGATE BASE COURSE)
	STRUCTURE BACKFILL MATERIAL, RE: STRUCTURAL NOTES AND GEOTECH		BEDDING MATERIAL

Print Date:
 File Name: 55 SPECIAL STRUCTURE EXCAVATION AND STRUCTURE BACKFILL DETAILS.dwg
 Horiz. Scale: Vert. Scale:
 Unit Information Unit Leader

MARTIN/MARTIN
 CONSULTING ENGINEERS
 12499 WEST COLFAX AVENUE,
 LAKEWOOD, COLORADO 80215
 MAIN 303.431.6100
 MARTINMARTIN.COM

Sheet Revisions		
Date:	Comments	Init.
11/20/20	FINAL DESIGN REVIEW	M/M
02/03/21	FOR REVIEW	M/M
5/14/21	FOR BID	M/M
6/29/22	BID ADDENDUM	M/M



NOT FOR CONSTRUCTION	HOFFMAN WAY DRAINAGE IMPROVEMENTS STRUCTURE EXCAVATION AND STRUCTURE BACKFILL DETAILS	Project No./Code 19.1187
No Revisions:	Designer: LE/TNS	
Revised:	Detailer: MNG	
Void:	Sheet Subset: STRUCT	Subset Sheet: SHEET NO. 55

PLOT DATE: Wednesday, June 29, 2022 11:23 PM LAST SAVED BY: MGEIGER
DRAWING LOCATION: G:\HORN\19.1187-Hoffman Way - Parallel Drainage System\PLANS\CDs\STRUCT\56 STRUCTURAL GEOMETRIC LAYOUT.dwg 56 STRUCTURAL GEOMETRIC LAYOUT

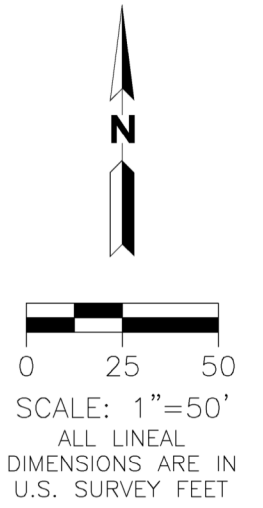
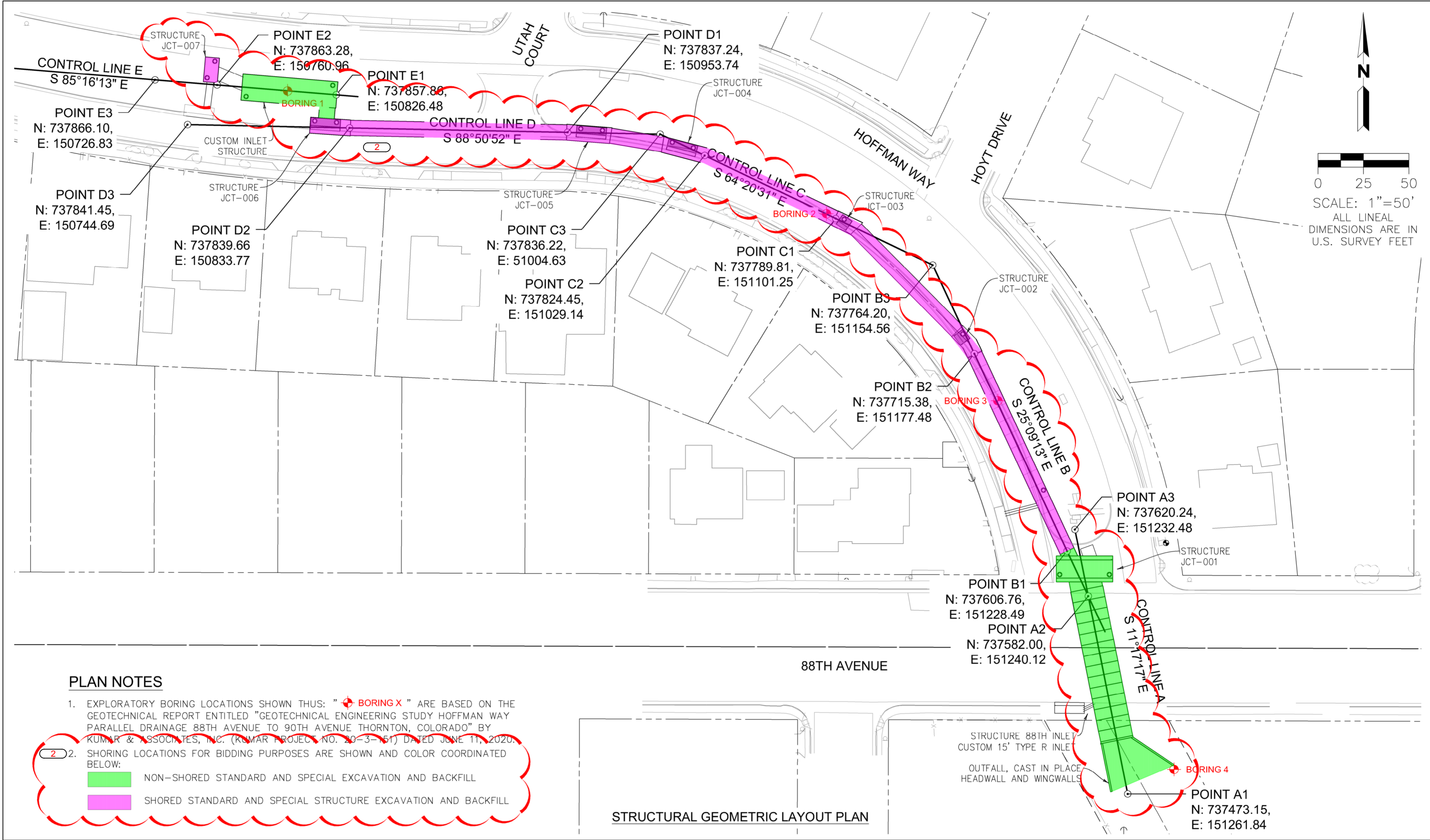

PLAN NOTES

- EXPLORATORY BORING LOCATIONS SHOWN THUS: "BORING X" ARE BASED ON THE GEOTECHNICAL REPORT ENTITLED "GEOTECHNICAL ENGINEERING STUDY HOFFMAN WAY PARALLEL DRAINAGE 88TH AVENUE TO 90TH AVENUE THORNTON, COLORADO" BY KUMAR & ASSOCIATES, INC. (KUMAR PROJECT NO. 20-3-151) DATED JUNE 11, 2020.
- SHORING LOCATIONS FOR BIDDING PURPOSES ARE SHOWN AND COLOR COORDINATED BELOW:
 - NON-SHORED STANDARD AND SPECIAL EXCAVATION AND BACKFILL
 - SHORED STANDARD AND SPECIAL STRUCTURE EXCAVATION AND BACKFILL

STRUCTURAL GEOMETRIC LAYOUT PLAN

Print Date:	
File Name:	56 STRUCTURAL GEOMETRIC LAYOUT.dwg
Horiz. Scale:	Vert. Scale:
Unit Information:	Unit Leader:
12499 WEST COLFAX AVENUE, LAKEWOOD, COLORADO 80215 MAIN 303.431.6100 MARTINMARTIN.COM	

Sheet Revisions		
Date:	Comments	Init.
11/20/20	FINAL DESIGN REVIEW	M/M
02/03/21	FOR REVIEW	M/M
5/14/21	FOR BID	M/M
6/29/22	BID ADDENDUM	M/M



NOT FOR CONSTRUCTION	HOFFMAN WAY DRAINAGE IMPROVEMENTS		Project No./Code
No Revisions:	STRUCTURAL GEOMETRIC LAYOUT		19.1187
Revised:	Designer: LE/TNS		
Void:	Detailer: MNG		
	Sheet Subset: STRUCT	Subset Sheet:	SHEET NO. 56

PROJECT TECHNICAL SPECIFICATIONS – Revised
Hoffman Way – Parallel Drainage System – 88th Avenue to 90th Avenue
Project No. 19-244

The latest editions of the 2019 CDOT Standard Specifications for Road and Bridge Construction and Thornton Engineering Construction Standards and Specifications control construction of this project.

The following special provisions supplement or modify the Standard Specifications and take precedence over the Standard Specifications and plans.

PROJECT SPECIAL PROVISIONS

DIVISION 100 – GENERAL PROVISIONS

REVISION OF SECTION 106 CONTROL OF MATERIALS

REVISION OF SECTION 201 CLEARING AND GRUBBING

REVISION OF SECTION 202 REMOVAL OF STRUCTURES AND OBSTRUCTIONS

REVISION OF SECTION 203 EXCAVATION AND EMBANKMENT

REVISION OF SECTION 206 EXCAVATION AND BACKFILL FOR STRUCTURES

REVISION OF SECTION 208 EROSION CONTROL

REVISION OF SECTION 209 WATERING

REVISION OF SECTION 212 SEEDING, FERTILIZER, SOIL CONDITIONER AND SODDING

REVISION OF SECTION 213 MULCHING

REVISION OF SECTION 214 PLANTING

REVISION OF SECTION 216 SOIL RETENTION COVERING

REVISION OF SECTION 304 AGGREGATE BASE COURSE

REVISION OF SECTION 306 RECONDITIONING

REVISION OF SECTION 401 PLANT MIX PAVEMENTS – GENERAL

REVISION OF SECTION 403 HOT MIX ASPHALT

REVISION OF SECTION 506 RIPRAP

REVISION OF SECTION 514 PEDESTRIAN AND BIKEWAY RAILING

REVISION OF SECTION 601 STRUCTURAL CONCRETE

REVISION OF SECTION 602 REINFORCING STEEL

REVISION OF SECTION 603 CULVERTS AND SEWERS

REVISION OF SECTION 604 MANHOLES, INLETS, AND METER VAULTS

REVISION OF SECTION 608 SIDEWALKS AND BIKEWAYS

REVISION OF SECTION 609 CURB AND GUTTER

REVISION OF SECTION 614 TRAFFIC CONTROL DEVICES

REVISION OF SECTION 625 CONSTRUCTION SURVEYING

REVISION OF SECTION 627 PAVEMENT MARKINGS
REVISION OF SECTION 629 SURVEY MONUMENTATION
REVISION OF SECTION 630 CONSTRUCTION ZONE TRAFFIC CONTROL
REVISION OF SECTION 630 PORTABLE MESSAGE SIGN PANEL
REVISION OF SECTION 630 UNIFORMED TRAFFIC CONTROL
REVISION OF SECTION 716 WATER LINE MATERIALS (SLUDGE LINE)
TRAFFIC CONTROL PLAN – GENERAL
UTILITY SPECIFICATIONS
FORCE ACCOUNT ITEM

APPENDIX A - SOILS REPORT
APPENDIX B - SUBMITTALS

**REVISION OF DIVISION 100
GENERAL PROVISIONS**

Unless otherwise noted in this section, all Division 100 General Provisions are deleted and replaced with the City of Thornton's Contract Documents included in Volume 1.

Any references to Division 100 in Divisions 200 through 700 are removed. The City of Thornton General and Special Provisions shall apply for any removed provisions.

1
REVISION OF SECTION 106
CONTROL OF MATERIALS

Section 106 of the Standard Special Provisions is hereby replaced with the following

106.01 Quality Control Testing. The Contractor shall be responsible for Quality Control Testing for this project. The following minimum testing shall be included:

1. Sampling and testing for HMA:

Element	Process Control	Acceptance ^{1,2}	Check (CTP)
Asphalt Content	1/500 tons	1/1000 tons	1/10,000 tons
Gradation	1/Day	1/2000 tons	1/20,000 tons
Theoretical Maximum Specific Gravity	1/1000 tons, minimum 1/Day	1/1000 tons, minimum 1/Day	1/10,000 tons
In-place Density	1/500 tons	1/500 tons	1/5000 tons
Joint Density	1 core/2500 linear feet of joint	1 core/5000 linear feet of joint	1 core/50,000 linear feet of joint
Aggregate Percent Moisture	1/2000 tons, minimum 1/Day	1/2000 tons	Not applicable

Notes for Table 106-1:

¹ The minimum number of acceptance tests will be: 5 asphalt content, 3 gradation, 10 in-place density and 5 joint density for all projects.

² When unscheduled job mix formula changes are made (Form 43) acceptance of the elements, except for in-place density, will be based on the actual number of samples that have been selected up to that time, even if the number is below the minimum listed in the schedule. At the Engineer's discretion, additional random in-place density tests may be taken in order to meet scheduled minimums, provided the applicable pavement layer is available for testing under safe conditions. Beginning with the new job mix formula, the quantity it will represent shall be estimated. A revised schedule of acceptance tests will be based on that estimate.

2. Existing Soils:

- 4 Proctor tests for existing soils

3. Compaction Testing - Subgrade:

- Field moisture-density tests shall be required at random locations at the rate of one (1) for each 250 linear feet of paving for each travel lane.

4. Compaction Testing – Aggregate Base Course:

- At least one (1) sample of aggregate base course for each 1,000 tons of material placed shall be tested to determine gradation and Atterberg limits.
- During placement and compaction, Compaction Curves shall be required for each material used.

- Field moisture-density tests shall be taken of each lift of material at random locations, at approximate intervals of 250 feet in each travel lane. At least 20% of the tests shall be taken within one (1) foot of manholes, valves and curbs.

5. Compaction Testing - Fill:

- In-place moisture-density / percent relative compaction: 1 per 500 cu yds. or fraction thereof with one additional test required per change in material type being placed with minimum 1 test per lift.

106.02 Measurement and Payment

The cost of sampling, testing, and corrective action by the Contractor will not be paid for separately but shall be included in the work.

END OF SECTION REVISION

1
**REVISION OF SECTION 201
CLEARING AND GRUBBING**

Section 201 of the Standard Specifications is hereby revised for this project as follows:

Subsection 201.01 shall include the following:

Any clearing, grubbing, and tree trimming/removal activities that occur between 1 April and 31 August requires a migratory bird nest check by a qualified biologist to make sure no occupied nests are affected by these activities. Work outside of this nesting season can occur without this check. The Contractor shall coordinate this work through the Engineer.

All trees and shrubs adjacent to and within the project limits shall be protected with the exception of those specified within the plans to be removed.

Removal of small brush and trees with trunk diameter less than 6-inches will not be measured and paid for separately but shall be included in the work.

Temporary easement areas shall not be cleared and grubbed unless absolutely necessary for construction purposes. Limits of clearing and grubbing shall be field verified by the Owner after field staking has been completed and prior to clearing and grubbing.

Subsection 201.01 shall include the following:

The Contractor shall make necessary arrangements for obtaining suitable disposal locations. If disposal will be at other than established dump sites, the City may require the Contractor to furnish written permission from the property owner on whose property the materials and debris will be placed.

Subsection 201.02 delete the 3rd, 4th, and 5th paragraphs and replace them with the following:

Surface objects and trees, stumps, roots, and other protruding obstructions not designated to remain shall be cleared and/or grubbed as required, to ensure complete removal; however, nonperishable, non-toxic objects which shall be a minimum of two (2) feet below subgrade may remain when such objects will not impede other subsurface operations.

Except in areas to be excavated, stump holes, and other holes from which obstructions are removed shall be backfilled with suitable material and compacted in accordance with subsection 203.06. Materials and debris shall be disposed of in a manner acceptable to the City.

Burning of any materials shall not be permitted without prior written approval of the City, the County Health Department, and Fire Department. If permitted, perishable material shall be burned under the constant care of the Contractor, at times and in a manner that will not endanger the surrounding vegetation, adjacent property, or objects designated to remain. Burning shall be done in accordance with applicable laws and ordinances.

2
REVISION OF SECTION 201
CLEARING AND GRUBBING

Subsection 201.02 Construction Requirements shall include the City of Thornton Protection of Existing Facilities Standards as follows:

I. Protection of Existing Facilities

- A. A plant material protection zone shall be identified on a plan and be submitted with the approved construction drawings.
1. The existing condition of all plant material in the construction area shall be reviewed by a third-party ISA Certified Arborist or City Staff at the discretion of the Senior Landscape Architect.
 2. Any activity determined to be injurious to existing plant material shall not be permitted within the plant material protection zone. These activities include grading, rototilling, equipment storage, vehicle parking, stockpiling of soil, or other activities which may cause soil compaction or disruption. Plant material damaged during construction and not included on the approved mitigation plan shall be valued toward additional replacement plant material in accordance with City policy.
 3. One of the following methods shall be used to determine the plant material protection zone:
 - a) Dripline Method: Protect the area within the tree's dripline for broad-canopied trees, or up to 1.5 times the tree's dripline for narrow-canopied trees.
 - b) b. Tree Height Method: Protect a circular area around the tree with the radius being equal to the height of the tree. This is the preferred method and should be used if there is enough space available. This method should also be used for narrow-canopied trees that have root systems extending beyond the tree's dripline.
 - c) Trunk diameter Method: for every inch of trunk diameter at 4.5 feet above the grade, allow for 11.5 feet of circle radius from the trunk.
- B. The plant material protection zone on a site shall be enclosed with protective fencing. Protective fencing shall be orange plastic or metal chain link, a minimum four (4) feet in height, secured with metal posts and signed to indicate that the area is set aside for the protection of plant material. Absolutely no grading shall be permitted within the plant material protection zone. Supplemental irrigation may be required for protected plant materials from May-October.
- C. Pruning shall be required for all plant material to be saved in the work area to the extent required to permit clean and workmanlike finish grading, seeding, or sodding operation under and around plant material.

**REVISION OF SECTION 201
CLEARING AND GRUBBING**

D. If authorization has been granted to excavate within the dripline of plant material, do so in a manner that will cause minimum damage to root systems. Prune the injured roots cleanly and backfill as soon as possible. Do not leave surface roots exposed. To minimize damage to the roots, boring may be required within the dripline, as directed by the Senior Landscape Architect.

1. Do not cut any root over two (2) inches in diameter within the dripline except when authorized by the Senior Landscape Architect.
2. Do not use trees for any purpose such as crane stays, guy anchors, shaded material storage, etc.

No paint, oil, volatile materials, or any substance that might cause damage to existing or future vegetation shall be spilled or buried in the vicinity of the construction area. Any spillage shall be immediately removed and properly disposed of at the direction of the Development Engineering Manager.

In Subsection 201.04 delete the 4th paragraph and replace with the following:

If approved of by the City prior to the work, clearing and grubbing beyond the limits designated under this item will be paid for as Extra Work in accordance with Section 8 of the City of Thornton's General Condition.

END OF SECTION REVISION

1

**REVISION OF SECTION 202
REMOVAL OF STRUCTURES AND OBSTRUCTIONS**

Section 202 of the Standard Specifications is hereby revised for this project as follows:

In Subsection 202.02 delete the 1st paragraph and replace with the following:

The Contractor shall raze, remove, and dispose of foundations, signs, structures, fences, pavements, utilities, traffic signal materials, and other obstructions, which are designated for demolition within the project limits, except for utilities and for materials which are to be preserved or salvaged.

Subsection 202.11 shall include the following:

When specifically noted on the drawings, the Removal of Full Depth Asphalt Pavement shall include the removal of all aggregate base course material below the asphalt to native soil. The Removal of aggregate base course under existing asphalt shall be considered incidental to Removal of Full Depth Asphalt Pavement.

There will be no measurement and payment for saw cutting required for the removal of asphalt and concrete. Saw cutting shall be considered incidental to bid items which require saw cutting.

The Removal of Pavement Markings for traffic control will not be measured and paid for separately but shall be considered incidental to Construction Traffic Control Items.

The Removal of Trees shall include tree stumps and roots. The Contractor shall visit the site to view all trees that are designated to be removed. Several trees have multiple trunks. Removal of trees with multiple trunks shall be considered removal of one tree.

Subsection 202.11 delete the 2nd sentence of paragraph 2 and replace it with the following:

Sand blasting required for removal of existing pavement marking shall be considered incidental to Removal of Pavement Markings.

2

**REVISION OF SECTION 202
REMOVAL OF STRUCTURES AND OBSTRUCTIONS**

Subsection 202.12 shall include the following:

Payment includes all labor, equipment and materials necessary to complete the work. All costs associated with stockpiling, safekeeping, and delivering salvaged materials to the City of Thornton shall be included.

No material or debris shall be disposed of within the project limits without the written permission of the Engineer. The Contractor shall advise the Engineer in writing of the intended disposal site before the disposal site is used; and provide documentation confirming the property owner's acceptance of such materials.

Payment will be made under:

Pay Item	Pay Unit
Removal of Full Depth Asphalt	Square Yard
Removal of Concrete Curb and Gutter	Linear Foot
Removal of Sidewalk (Concrete)	Square Yard
Removal of Tree	Each
Removal of Shrub	Each
Removal of Inlet (15-ft Type R)	Each
Removal of Inlet (30-ft Type R)	Each
Removal of Inlet (Special)	Each
Removal of Manhole	Each
Storm Sewer Removal	Linear Foot
Removal of Ground Sign	Each

END OF SECTION REVISION

1
SECTION 203
EXCAVATION AND EMBANKMENT

Section 203 of the Standard Specifications is hereby revised for this project as follows:

Subsection 203.01 shall include the following:

Removal and replacement of unsuitable material for unclassified excavation (cut/fill) and structures including but not limited to storm sewers, waterline, sanitary sewers, manholes, tees, junction boxes, inlets and culverts is also included in this section.

Subsection 203.02 shall include the following:

Unsuitable Materials shall consist of the removal of mixtures of soils and organic matter not suitable for foundation material and replacement with approved material per the geotechnical engineer. Unsuitable Materials does not apply to special structure excavation requirements.

Unclassified excavation (cut/fill) consists of earthwork outside of structure excavation that is required for the work.

Subsection 203.03 shall include the following:

Dewatering Considerations: Groundwater may be encountered in excavations extending to or below depths of about 10 feet. Excavations extending below groundwater should be properly dewatered prior to, and during the excavation process to help maintain the stability of the excavation side slopes and stable subgrade conditions for construction and fill placement.

Excavations extending a few feet or more below groundwater may require more extensive dewatering. Selection of a dewatering system should be the responsibility of the contractor. Dewatering quantities will depend on excavation size, water table drawdown, and soil permeability. Accordingly, low quantities should be anticipated at the site. Dewatering systems should also be properly designed to prevent piping and removal of soil particles which could have damaging effects.

Dewatering Considerations: Groundwater may be encountered in excavations extending to or below depths of about 10 feet. Excavations extending below groundwater should be properly dewatered prior to, and during the excavation process to help maintain the stability of the excavation side slopes and stable subgrade conditions for construction and fill placement.

Excavations extending a few feet or more below groundwater may require more extensive dewatering. Selection of a dewatering system should be the responsibility of the contractor. Dewatering quantities will depend on excavation size, water table drawdown, and soil permeability. Accordingly, low quantities should be anticipated at the site. Dewatering systems should also be properly designed to prevent piping and removal of soil particles which could have damaging effects.

2
SECTION 203
EXCAVATION AND EMBANKMENT

Subgrade Preparation: Subgrade preparation should consist of removal of the **unsuitable materials**, soft soil, and organics in the bottom. The earthwork may have to be performed by low ground pressure track construction equipment to prevent deflection of the subgrade.

After the **unsuitable material** and soft soil is removed, the underlying subgrade should be scarified and recompact to at least 95% of the standard Proctor (ASTM D698) maximum dry density at a moisture content near optimum. The prepared subgrade zone should be stable prior to application of the liner and/or additional fill placement. Soft or mucky subgrade soils may need to be stabilized with a layer of crushed rock or other means.

If required, any fill placed on the reconditioned subgrade may consist of materials similar to the on-site soils less organic material. New fills should be placed and compacted as indicated above. The prepared subgrade and fill placement should be observed by a representative of the geotechnical engineer.

General Site Grading Fill: Fill placed for general site grading or beneath pavements and exterior flatwork that is not sensitive to settlement should consist of on-site overburden soils or imported materials if required.

Material Suitability: Unless otherwise defined herein, all fill material should be a non-expansive soil free of vegetation, brush, sod, trash and debris, and other deleterious substances, and should not contain rocks or lumps greater than 4 inches in diameter. Fill material should be considered non-expansive if the material does not swell more than 0.5%, when remolded to 95% of the maximum dry unit weight at optimum moisture content as determined by ASTM D698 and wetted under a 200 psf surcharge pressure.

The existing on-site overburden soils should be suitable for use as general site grading and structural fill beneath exterior slabs, and pavements provided any organic or other deleterious material or debris are removed. The geotechnical engineer should evaluate the suitability of proposed import fill materials prior to placement. Evaluation of potential structural fill sources, particularly those not meeting the above liquid limit and plasticity index criteria, should include determination of laboratory moisture-density relationships and swell-consolidation tests on remolded samples prior to acceptance.

Moisture Content: Prior to compaction, fill materials should be adjusted to within 0 to + 3 percentage points of optimum moisture content for clayey soils and within ± 2 percentage points of the optimum moisture content for predominantly granular materials.

Placement and Degree of Compaction: Unless otherwise defined herein, compacted fill should be placed in maximum 8-inch thick loose lifts. The following compaction criteria should be followed during construction:

3
SECTION 203
EXCAVATION AND EMBANKMENT

	Percent Compaction ¹
Fill Location	
Beneath Foundations	98
Beneath Settlement-Sensitive Flatwork:	
Less than 8 feet below subgrade elevation	95
More than 8 feet below subgrade elevation	98
Utility Trenches:	
Less than 8 feet below subgrade elevation	95
More than 8 feet below subgrade elevation	98
Beneath Pavements:	
Less than 8 feet below subgrade elevation	95
More than 8 feet below subgrade elevation	98
Aggregate Base Course	95 ²

¹Relative to the maximum dry unit weight as determined by ASTM D 698.

²Relative to the maximum dry unit weight as determined by ASTM D 1557.

Subsection 203.05 (c) shall include the following:

The bid item for Unsuitable Material shall not be used without prior approval from the City.

Where excavation to the finished grade section results in a subgrade of unsuitable soil, ENGINEER may require CONTRACTOR to remove the unsuitable materials and replaced with structural fill per geotechnical material and placement requirements.

Disposal of the unsuitable material and replacement with suitable material shall be at CONTRACTOR's expense

Subsection 203.06, 2nd paragraph, shall the following:

Excavated or removed asphalt mat shall not be used in embankments.

Subsection 203.05(e) shall the following:

Stripping shall not be completed outside of the limits of construction or limits of disturbance.

In Subsection 203.11 delete the first paragraph.

Subsection 203.11 shall include the following:

Earthwork requiring more than one handling will not be measured and paid for separately but shall be considered incident to the Excavation and Embankment quantities listed in the bid schedule.

3
SECTION 203
EXCAVATION AND EMBANKMENT

In Subsection 203.11 delete subparagraphs (a) and (b) and replace with the following:

Quantities for **Unclassified Excavation (cut/fill)** Complete in Place and Embankment Complete in Place shall not be measured, but shall be the quantities designated in the Contract. The Contractor is responsible for verifying the quantities prior to completing their bid. If the Contractor believes that the quantities of earthwork are different than those presented on the bid schedule, then the Contractor shall adjust their bid prices accordingly.

Stripping will not be measured and paid separately but shall be considered incidental to the bid items for earthwork.

In Subsection 203.11 delete subparagraph (f) and replace with the following:

Proof Rolling shall be considered incidental to reconditioning and will not be measured and paid for separately.

Subsection 203.12 shall include the following:

Disposal of unsuitable material and importing suitable material will not be paid for and shall be considered incidental to the bid item for Unsuitable Materials. The bid item for Unsuitable Materials shall include but is not limited to excavation, haul, disposal of unsuitable material, importing suitable material, moisture conditioning, compaction, water, and all labor, materials, and equipment required to removal and replace unsuitable material.

Subsections 203.12 shall include the following

Pay Item	Pay Unit
Unsuitable Materials	Cubic Yard
Unclassified Excavation (Cut/Fill)	Cubic Yard

END OF SECTION REVISION

1
REVISION OF SECTION 206
EXCAVATION AND BACKFILL FOR STRUCTURES

Section 206 of the Standard Specifications is hereby revised for this project to include the following:

Subsection 206.01 shall include the following:

Excavation and backfill for all structures including but not limited to storm sewers, waterline, sanitary sewers, manholes, tees, junction boxes, inlets and culverts is also included in this section.

Subsection 206.02 shall include the following:

Structural Fill beneath Spread Footing, Rigid Slabs, and Settlement-Sensitive Exterior Flatwork: Structural fill should consist of the on-site overburden soils, or if needed, imported structural fill materials that are non-expansive soils with a maximum of 60% passing the No. 200 sieve and a maximum liquid limit and plasticity index of 30 and 12, respectively. Imported fill materials not meeting these criteria may be acceptable if they meet the swell criteria presented below.

Fill material should be considered non-expansive if the material does not swell more than 0.5%, when remolded to 95% of the maximum dry unit weight at optimum moisture content as determined by ASTM D698 and wetted under a 200 psf surcharge pressure.

Subsections 206.06 and 206.07 are hereby deleted and replaced with the following:

There will be no Measurement and Payment for this item. The cost for Excavation and Backfill for Structures shall be included in the unit prices bid for all work requiring Structure Excavation and Backfill.

Subsection 206.08 shall include the following:

In addition to specific areas requiring shoring shown in the plans, shoring may be necessary in miscellaneous locations such as to protect existing utilities.

Subsection 206.10 is hereby deleted and replaced with the following:

Shoring will not be measured but shall be included in the unit prices bid for associated structures or pipes requiring shoring.

Subsections 206.11 is hereby deleted and replaced with the following:

There will be no Measurement and Payment for this item.

Payment for shoring, included in the unit prices bid for associated structures and pipes, will be full compensation for all labor, materials, and equipment required to design, construct, and remove the shoring.

END OF SECTION REVISION

1

**REVISION OF SECTION 208
EROSION CONTROL**

Section 208 of the Standard Specifications is hereby revised as follows:

Section 208.01 shall include the following:

The contractor is responsible for necessary modifications to the erosion control plan to support phasing and shall always maintain proper perimeter controls throughout construction.

The first paragraph in Section 208.11 is replaced with the following:

Payment will be made under:

Pay Item	Pay Unit
Aggregate Bag (Rock Sock)	Each
Concrete Washout Structure	Each
Rock Check Dam	Each
Silt Fence	Linear Foot
Inlet Protection	Each
Stabilized Staging Area	Each
Vehicle Tracking Control	Each

Paragraph 5 after the list of pay items in Section 208.12 is deleted.

Section 208.12 shall include the following:

Erosion Control Management, Removal and Disposal of Sediment (Equipment), Removal and Disposal of Sediment (Labor), Sweeping and Trash Removal will not be measured and paid for separately but shall be considered incidental to the project.

END OF SECTION REVISION

1
REVISION OF SECTION 209
WATERING

Section 209 of the Standard Specifications is hereby revised for this project as follows:

Subsection 209.02 shall include the following:

The Contractor is responsible for obtaining a legal source for water to complete the work as specified in the Contract Documents, including any necessary permits or fees.

Subsection 209.07 and 209.08 are deleted and replaced with the following:

Water required for all work covered under the Contract will not be measured and paid for separately but shall be included in the work. Contractor shall obtain a water meter, for a refundable deposit, from the City of Thornton which is to be used for site project watering.

END OF SECTION REVISION

1

**REVISION OF SECTION 212
SEEDING, FERTILIZER, SOIL CONDITIONER, AND SODDING**

Section 212 of the Standard Specifications is hereby modified to add the City's specific requirements as follows:

Subsection 212.02 Seed, Soil Conditioners, Fertilizers, and Sod shall include the City of Thornton Sodding Standards as follows:

SOIL PREPARATION - LANDSCAPED AREAS

General

Prior to soil preparation the Contractor shall remove all construction debris from the soil including: large rocks, concrete, asphalt and soil clods; all building materials such as boards, insulation, shingles, rebar, wire, and grading stakes. Before soil preparation, the Contractor shall rip the soil to a minimum depth of 12 inches if it has been compacted by heavy machinery or by working it while wet and in the sole opinion of the Owner.

Materials

A. Organic Materials

Organic soil amendment for all landscape areas, including all turf, native seed, tree, shrub planting beds in their entirety, annual, vine, and groundcover areas shall be a Class I Compost that meets the U.S. Composting Council's testing requirements. The compost must be produced at a composting facility meeting EPA 40 CFR 503.13 requirements for the production and marketing of Class A material for unrestricted use and distribution. Amending only the planting hole is not acceptable.

After representative soil sample analysis, apply the following to all planted areas, including the total square footage of planting beds. Distribute uniformly and thoroughly mix to a depth of 12", unless restricted by existing tree roots:

- Compost
 - Compost shall be 6 cy/1000 **SF** as minimum 2" depth 'Biocomp' Class 1 non-manure based compost as supplied by A-1 Organics, Eaton, Colorado, or approved equal. Mix shall be screened to 3/8" minus and free from stones, lumps, plants, roots, sticks, weed stolons, seeds, high salt content and other materials harmful to plant life.
 - Minimum 25% and maximum 35% organic matter measured on dry weight basis
 - pH range 6.0 to 7.0 (7.0 is neutral)
 - EC electrical conductivity (soluble salts) 2.0-5.0 mmhos/cc @1:5 (compost:water weight ratio)
 - Carbon nitrogen C:N ratio 10:1 to 12:1; 12-16 may be acceptable
 - Submit for approval at least 14 days prior to site delivery a one-gallon sample with laboratory analysis specific to the sample dated within thirty days of date of submittal.
- Starter Fertilizer

2

**REVISION OF SECTION 212
SEEDING, FERTILIZER, SOIL CONDITIONER, AND SODDING**

- Granular fertilizer 18-46-0 at the rate of 3 lb/1000 SF with the following composition by weight: Nitrogen, eighteen percent (18%) and phosphoric acid (P205), forty-six percent (46%). These elements may be organic, inorganic, or a combination of the two, and shall be measured according to the methods of the Association of Official Chemists.
- Do not apply pre-emergent

Preparation

A. Noxious Weed Control

If the area to be developed is infested with bindweed, thistle or other noxious weeds, such vegetation shall be completely eradicated by application(s) of a systemic, non-selective herbicide like glyphosate (Roundup) or approved equivalent. All herbicides shall be applied by an applicator licensed by the State of Colorado Department of Agriculture at a rate and period required by the manufacturer's labeling instructions.

B. Ripping of Compacted Soils

Soils previously compacted by heavy machinery during construction, as identified by the Owner, shall be ripped prior to required soil amendment incorporation. The ripping equipment used shall rip the soil in rows no greater than 18" apart, and shall be powerful enough to rip the soil to a minimum depth of 12". Ripping operations shall be timed to commence when soil moisture is adequate enough to allow penetration, but is not at all wet or muddy.

C. Soil Amendments

1. A minimum 6 cubic yards per 1,000 sf of a Class I compost shall be distributed across the soil surface of all landscape areas in a uniform 1 $\frac{1}{3}$ " (6 cubic yards = 2 inch layer) and incorporated into the top 8 inches of soil with a rototiller capable of tilling to 8 inches in depth. Shrub beds shall be amended throughout the entire bed prior to planting, not just the planting hole.
2. Native grass seeding: broadcast 1500 lbs/Ac Biosol Forte Mix 7-2-3, or approved equal, before seeding.

E. Final Grading

The finished surface shall be even and uniform and no dirt clumps, stones, sticks, residual plant material, or other debris larger than one (1) inch in diameter shall appear on the surface. When sodded areas are next to fixed surfaces such as walks, curbs, or borders, finished grade prior to sodding shall be 1.5 inches below such surfaces.

Subsection 212.05 Sodding shall include the City of Thornton Sodding Standards as follows:

II. Materials

E. Sod

1. Turfgrass blends and mixes shall be selected based on site conditions, intended use, and water conservation; and shall be approved by the owner.
2. Sod shall be healthy and certified by the State of Colorado as insect, disease, and noxious weed free. The cultivars that comprise each sod blend or mix must test well above average on the National Turfgrass Evaluation Program trials. The sod shall be mowed at two (2) inches and thoroughly watered before harvested. All sod shall be cut to provide a minimum thickness of three-fourths ($\frac{3}{4}$) inch of soil adhering to the roots. Each sod strip shall be harvested in a minimum width of 16 inches and a minimum length of 24 inches. Sod may be supplied in wider and longer rolls.
3. The following turfgrass blends and mixtures are approved for use as sod in the City of Thornton and shall be specified on the approved plans:
 - a. Kentucky Bluegrass (*Poa pratensis*) Must be a blend of at least three (3) improved cultivars (varieties) that are acclimated to Thornton's growing conditions.

III. Process

A. Care and Handling

Care shall be exercised at all times to retain the soil on the sod roots during transportation, handling, and planting. Dumping sod from vehicles shall not be permitted. The sod shall be installed within 24 hours from the time it is cut, unless it can be stored to the satisfaction of the Owner. During delivery and while in stacks, all sod

shall be kept moist and protected from drying, sun, or freezing. All damaged sod shall be rejected. All sod discolored due to excessive drying shall be rejected.

B. Transporting Sod On-site

Sod can be transported on or across the site on pallets by forklift, bobcat, or equivalent. Damage to the sod bed by the vehicles shall be avoided; any damage shall be repaired prior to sodding of the area. Damage caused to paving, curbs, fences, plants or other objects from sodding operations shall be remedied by the Contractor at his expense, as directed by the Owner.

Subsection 212.06 Native Seeding shall include the City of Thornton Natural Seed Areas Installation and Maintenance Standards as follows:

Native seeding shall be in accordance with Mile High Flood District Specifications

Native seeding Initial & Final Acceptance shall be according to city guidelines.

1. **Substantial Completion** may be issued before native seed establishment meets applicable contract specifications and city standards, but Initial Acceptance will not occur until establishment standards, in the sole opinion of the Owner, have been met.
2. **Initial Acceptance** may occur when the city has received and approved all product certifications and quantities and given written acknowledgement that the designated area has been prepared, seeded, mulched and maintained to meet the specification requirements. Seeded areas will be accepted upon the establishment of an even, uniform grass cover of the seed varieties planted. This does not imply that a full sod is necessary. The result is based on a visual evaluation indicating a uniform ground cover of about 90% germination with no bare spots larger than 6" diameter and the area free of weeds and surface irregularities (no rills and gullies), as determined by Owner. Re-seed any areas where seed has not germinated within the total seeding area. Continue this procedure until a successful stand of grass is growing and accepted by the Owner.
 - Contractor shall maintain seeded area until Initial Acceptance.
 - Re-grading, reseeding, re-mulching and weed control is required until Initial Acceptance for areas of little or no seed germination and to repair areas damaged by erosion, wind, vandalism, fire or other causes.
 - Initial Acceptance of seeded area shall meet Stormwater Discharge Permit obligations.
3. **Final Acceptance** may occur one year after Initial Acceptance when the stand of grass displays uniform coverage at minimum three to five leaf stage of the seed mix planted (minimum 80% healthy grass coverage over any 10 square foot area and bare spots not exceeding 10" by 10"), with all species of the mix being well represented, minimal weeds present and the area free of surface irregularities (no rills & gullies), as determined by the city.
 - Final Acceptance of seeded area shall meet Stormwater Discharge Permit obligations and requirements of the Corps of Engineers Nationwide Permit for seeded area coverage, as applicable.
 - Any areas that do not comply with Final Acceptance criteria shall be reseeded by the Contractor in accordance with these specifications, using specified materials and methods.
 - Hydromulch may not be required by the city in reseeded areas.

BASIS OF PAYMENT

The accepted quantity of native seeding will be paid for at the contract unit price for each of the pay items listed below that appear in the bid schedule.

Payment will be made under:

Pay Item	Pay Unit
Tree Retention and Protection	Lump Sum
Native Seeding	Square Foot
Sodding	Square Foot

Payment shall be made at the applicable contract unit price for Bid Item and shall include full compensation for all labor, equipment, tools, and materials necessary to complete the work. Payment for landscape restoration shall include all landscaping, sod, piping, wiring, valves, sprinkler heads, drip emitters, fittings, excavation, backfill, and all other items of work involved in the reset and modifications necessary to the irrigation systems to complete the work.

Soil preparation, water, seed, fertilizer, hydro mulch, and soil conditioner, incorporated into the seeding sodding or soil conditioning will not be paid for separately but shall be included in the work.

Adjusting or readjusting seeding or fertilizing equipment will not be paid for separately but shall be included in the work.

END OF SECTION REVISION

1
REVISION OF SECTION 213
MULCHING

Section 213 of the Standard Specifications is hereby revised for this project as follows:

Subsection 213.03, paragraph (a) shall include the following:

Hydromulch shall be maintained in all areas of seeding.

Subsection 213.04 and 213.05 shall be revised to include the following:

No separate measurement and payment will be made for mulch tackifier. Mulch tackifier shall be considered as incidental to seeding.

Payment will be made under:

Pay Item	Pay Unit
Mulching (Wood Chip)	Cubic Yard
Mulching (Gravel)	Square Foot

END OF SECTION REVISION

1
REVISION OF SECTION 214
PLANTING

Section 214 of the Standard Specifications is hereby revised for this project as follows:

Subsection 214.03 shall include the following:

Trees planted in sod, turf, or grass require tree trunk protectors. At the time of planting, install a nine (9) inch tall, expandable tree trunk protector such as Arborgard+ or approved equal. This requirement is in addition to the mulch ring specified on the planting detail 800-1. Trees damaged by string trimmers or mowers during the warranty period will be required to be replaced.

A. Mulching

1. Immediately prior to plant bed mulching, obtain inspection and approval of planting bed irrigation system in operation. Bed areas shall be free from grass and weeds immediately prior to mulching.

2. Double shredded wood cedar mulch (gorilla hair) shall be installed per the planting details.

Remove tree stakes one (1) year following Initial Acceptance, before Final Acceptance. Trees located in City maintained areas shall be tagged at nursery by City Forester. Trees shall be wrapped in Fall and unwrapped in Spring by contractor until Initial Acceptance by City.

WINTER WATERING: Winter watering is required by the contractor the winter after Initial Acceptance.

1. Provide winter watering of plant materials as needed. Notify the Owner at least two (2) working days in advance when winter watering is needed, and, upon Owner's request, adjust watering schedules as needed to allow for Owner's presence during watering.
2. Periodically check soil moisture and the condition of plant material throughout the warranty period, and notify the Owner in writing when over/under watering is identified during the irrigation season.
3. For the period between irrigation system winterization and subsequent spring start-up, monitor weather conditions and provide soil moisture checks at least twice per month and notify the Owner in writing regarding soil moisture conditions.
4. Contractor is responsible for a minimum of five site visits for winter watering. Notify Owner at least 48 hours in advance of site watering visit. Owner shall be in attendance to document each winter watering in writing as part of the Final Acceptance process.
5. When winter watering, deliver the following minimum amounts of water to each plant: 15 gal. per B&B tree; 3-5 gal. per #5 shrub/ornamental grass; and 2-3 gal. per 100 s.f. (approx. 2") in #1 or perennial planting areas. If irrigation system is charged to water, contractor shall winterize system after each use.

6. Under no circumstances shall plant warranties be voided by Contractor's claims of inadequate or excessive watering.
7. Established trees impacted by construction shall receive approximately 100 gallons/water per week winter watering.

END OF SECTION REVISION

1
REVISION OF SECTION 216
SOIL RETENTION COVERING

Section 216 of the Standard Specifications is hereby revised for this project as follows:

In Subsection 216.07, 1st paragraph, delete the last sentence and replace with the following:

Earth anchors will not be measured and paid for separately but shall be included in the work.

In Subsection 216.08, 1st paragraph, delete the last sentence and replace with the following:

Earth anchors will not be measured and paid for separately but shall be included in the work.

Pay Item	Pay Unit
Soil Retention Blanket (Straw)	Square Yard

END OF SECTION REVISION

1
**REVISION OF SECTION 304
AGGREGATE BASE COURSE**

Section 304 of the Standard Specifications is hereby revised for this project as follows:

Delete Subsection 304.02 and replace with the following:

Aggregate base course materials shall be from a source approved by the City. The Contract shall provide a submittal including all material properties for review and approval prior to construction.

Materials for the base course shall be Aggregate Base Course (Class 6) as shown in subsection 703.03 – Aggregate for Bases

The Aggregate Base Course (Class 6) shall meet the gradation requirements and have a resistance value of at least 78 when tested by the Hveem Stabilometer method.

Acceptance will be based on random samples taken from each lift.

Subsection 304.04 shall include the following:

Materials shall be placed on an approved subgrade which has been proof-rolled within the past 24 hours and found to be stable and non-yielding. Should weather conditions change, such as freezing, precipitation, ect., aggregate base materials shall not be placed until the subgrade is reapproved.

Delete Subsection 304.07 and replace with the following:

Measurement shall be based on tons taken from the weight tickets provided to the City at time of delivery to the site.

Delete Subsection 304.08 and replace with the following:

Aggregate base course shall not be measured and paid for separately but shall be included in the work.

Water, labor, proof rolling, and equipment will not be measured and paid for separately but shall be included in the work.

Commercial mineral fillers, when used, shall be considered incidental to the bid item for Aggregate Base Course

END OF SECTION REVISION

1
REVISION OF SECTION 306
RECONDITIONING

Section 306 of the Standard Specifications is hereby revised for this project as follows:

Subsection 306.02 delete the first sentence and replace it with the following:

The top 12 inches of the existing subgrade shall be reconditioned by blading and rolling.

Reconditioning shall not be measured and paid for separately but shall be included in the work.

END OF SECTION REVISION

1
**REVISION OF SECTION 401
PLANT MIX PAVEMENTS – GENERAL**

Section 401 of the Standard Specifications is hereby revised as follows:

Subsection 401.01 shall include the following:

The City may require a pre-paving meeting of all parties involved in supply, haul, laydown inspection, quality control and quality acceptance of HMA. Areas of responsibility and contact names and numbers should be shared. A construction (joint) plan will be submitted at the pre-paving meeting.

In Subsection 401.02(a) delete the 5th paragraph and replace with the following:

The job-mix formula for Pavement shall be established by a testing laboratory approved by the Owner and at the Contractor's expense. Copies of all test data shall be provided to and approved by the Owner prior to construction.

Subsection 401.11 is deleted and replaced with the following:

When ordered by the Engineer or specified in the Contract, a tack coat shall be applied between pavement courses. Tack Coat will not be measured and paid for separately but shall be considered incidental to the project.

Subsection 401.16 shall include the following:

Removing Depressions:

Where local irregularities in the existing asphalt surface would otherwise result in a course more than 1-inch thicker than the nominal thickness after compaction, the surface shall be brought to uniform profile by placing a leveling course of Grade S bituminous pavement. Then thoroughly tamping or rolling until it conforms to the surrounding surface.

When the Contractor elects to conduct operations to eliminate depressions and place the surface course simultaneously, he shall furnish such additional spreading and compacting equipment as required to maintain the proper interval between the several operations, and only as approved by the Owner.

Subsection 401.22 shall include the following:

Costs associated with the pre-paving meeting shall be considered a part of the work and will not be paid for separately.

END OF SECTION REVISION

1
REVISION OF SECTION 403
HOT MIX ASPHALT

Section 403 of the Standard Specifications is hereby revised for this project as follows:

Subsection 403.02 shall include the following:

The design mix for hot mix asphalt shall conform to the following:

◆ Table 403-1							
Property	Test Method	Value for Grading					
				SX(75)	S(75)		Patching
Air Voids, percent at: N (design)	CPL 5115			3.5 – 4.5	3.5 – 4.5		3.5 – 4.5
Lab Compaction (Revolutions): N (design)	CPL 5115			75	75		75
Stability, minimum	CPL 5106			30	30		30
Aggregate Retained on the 4.75 mm (No. 4) Sieve for S, SX and SG, and on the 2.36mm (No. 8) Sieve for ST and SF with at least 2 Mechanically Induced fractured faces, % minimum*	CP 45			60	60		60
Accelerated Moisture Susceptibility Tensile Strength Ratio (Lottman), minimum	CPL 5109 Method B			80	80		80
Minimum Dry Split Tensile Strength, kPa (psi)	CPL 5109 Method B			205 (30)	205 (30)		205 (30)
Grade of Asphalt Cement, Top Layer				PG 76-28			PG 76-28
Grade of Asphalt Cement, Layers below Top					PG 64-22		PG 64-22
Voids in the Mineral Aggregate (VMA) % minimum	CP 48			See Table 403-2	See Table 403-2		See Table 403-2
Voids Filled with Asphalt (VFA), %	AI MS-2			65-75	65-75		65-75
Dust to Asphalt Ratio Fine Gradation Coarse Gradation	CP 50			0.6 – 1.2 0.8 – 1.6	0.6 – 1.2 0.8 – 1.6		0.6 - 1.2 0.8 – 1.6
Note:	AI MS-2 = Asphalt Institute Manual Series 2						
Note:	Mixes with gradations having less than 40% passing the 4.75 mm (No. 4) sieve shall be approached with caution because of constructability problems.						
Note:	Gradations for mixes with a nominal maximum aggregate size of one-inch or larger are considered a coarse gradation if they pass below the maximum density line at the #4 screen. Gradations for mixes with a nominal maximum aggregate size of 3/4" to 3/8" are considered a coarse gradation if they pass below the maximum density line at the #8 screen. Gradations for mixes with a nominal maximum aggregate size of #4 or smaller are considered a coarse gradation if they pass below the maximum density line at the #16 screen.						
	*Fractured face requirements for SF may be waived by RME depending on project conditions.						

2
REVISION OF SECTION 403
HOT MIX ASPHALT

All mix designs shall be run with a gyratory compaction angle of 1.25 degrees and properties must satisfy Table 403-1. Form 43 will establish construction targets for Asphalt Cement and all mix properties at Air Voids up to 1.0 percent below the mix design optimum. CDOT will establish the production asphalt cement and volumetric targets based on the Contractor's mix design and the relationships shown between the hot mix asphalt mixture volumetric properties and asphalt cement contents on the Form 429. CDOT may select a different AC content other than the one shown at optimum on the Contractor's mix design in order to establish the production targets as contained on the Form 43. Historically, Air Voids adjustments typically result in asphalt cement increases from 0.1 to 0.5 percent. Contractors bidding the project should anticipate this change and factor it into their unit price bid.

Table 403-2

Nominal Maximum Size*, mm (inches)	Minimum Voids in the Mineral Aggregate (VMA)			
	***Design Air Voids **			
	3.5%	4.0%	4.5%	5.0%
37.5 (1½)	11.6	11.7	11.8	N/A
25.0 (1)	12.6	12.7	12.8	
19.0 (¾)	13.6	13.7	13.8	
12.5 (½)	14.6	14.7	14.8	
9.5 (¾)	15.6	15.7	15.8	
4.75 (No. 4)	16.6	16.7	16.8	16.9
	* The Nominal Maximum Size is defined as one sieve larger than the first sieve to retain more than 10%. ** Interpolate specified VMA values for design air voids between those listed. *** Extrapolate specified VMA values for production air voids beyond those listed.			

The Contractor shall prepare a quality control plan outlining the steps taken to minimize segregation of HMA. This plan shall be submitted to the Engineer and approved prior to beginning the paving operations. When the Engineer determines that segregation is unacceptable, the paving shall stop and the cause of segregation shall be corrected before paving operations will be allowed to resume.

Hot mix asphalt for patching shall conform to the gradation requirements for Hot Mix Asphalt Grading SX for the top lift and Grading S for the bottom lifts.

A minimum of 1 percent hydrated lime by weight of the combined aggregate shall be added to the aggregate for all hot mix asphalt.

Acceptance samples shall be taken at the location specified in Method A of CP 41.

3
REVISION OF SECTION 403
HOT MIX ASPHALT

Subsection 403.03 shall include the following:

The Contractor shall construct the work such that all roadway pavement placed prior to the time paving operations end for the year, shall be completed to the full thickness required by the plans. The Contractor's Progress Schedule shall show the methods to be used to comply with this requirement.

At locations where new Hot Mix Asphalt is to abut existing asphalt, saw cut the existing pavement a minimum of 1 foot back from the existing edge with a neat line and remove pavement.

At patches, compaction shall initially be completed along the outside edges of the patch, and then proceed from the low side to the high side of the patch. The new asphalt patch shall have a minimum compacted thickness equal to the existing pavement thickness and be level and well matched to the existing pavement.

The Contractor shall commence placing hot mix asphalt within 3 working days after the street has been milled, and within 1 working day after the subgrade has been proof rolled, weather permitting.

The Contractor shall collect the scale ticket on each load when it is delivered to the project site, and ensure that the information required in by the City is shown on each ticket.

The scale tickets shall be available on site for City to inspect.

Each day the Contractor shall provide to the Engineer envelopes which contain the previous day's signed tickets and the following:

1. On each envelope: Project number, date of paving, type of material, daily total and cumulative total.
2. One of the following:
 - a) Two adding machine tape tabulations of the weight tickets with corresponding totals run and signed by different persons,
 - b) One signed adding machine tape tabulation of the weight tickets that has been checked and signed by a second person,
 - c) Signed check tape of computer scale tickets that have a cumulative total. These scale tickets must be consecutive and without voids adjustments.
3. A listing of any overweight loads on the envelope, including ticket numbers and amount over legal limit.
4. A comparison of the actual yield for each day's placement to the theoretical yield. Theoretical yield shall be based on the actual area paved, the planned thickness, and the actual density of the mixture being placed. Any variance greater than +2.5% shall be indicated on the envelope and a written explanation included.

4
REVISION OF SECTION 403
HOT MIX ASPHALT

The Contractor shall provide a vehicle identification sheet that contains the following information for each vehicle:

- 1) Vehicle number
- 2) Length
- 3) Tare weight
- 4) Number of axles
- 5) Distance between extreme axles
- 6) All other information required to determine legal weight.
- 7) Legal weight limit.

Delete Subsection 403.05 and replace with the following:

403.05 The accepted quantities of hot mix asphalt will be paid for in accordance with subsection 401.22, at the contract unit price per ton for the bituminous mixture.

Payment will be made under:

Pay Item	Pay Unit
Hot Mix Asphalt (Grading SX) (75) (PG 76-28) (2" Top Lift) (Full Depth)	Ton
Hot Mix Asphalt (Grading S) (75) (PG 64-22) (Bottom Lifts) (Full Depth)	Ton
Hot Mix Asphalt (Grading SX) (75) (PG 76-28) (Overlay)	Ton
Hot Mix Asphalt (Grading SX) (75) (PG 64-22) (Asphalt Trail)	Ton
Hot Mix Asphalt (Patching)	Ton

Aggregate, asphalt recycling agent, asphalt cement, additives, hydrated lime, and all other work and materials necessary to complete each hot mix asphalt item will not be paid for separately, but shall be included in the unit price bid. When the pay item includes the PG binder grade, any change to the submitted mix design optimum asphalt cement content to establish production targets on the Form 43 will not be measured and paid for separately, but shall be included in the work. No additional compensation will be considered or paid for any additional asphalt cement, plant modifications and additional personnel required to produce the HMA as a result in a change to the mix design asphalt cement content.

Historically, typical asphalt cement increases reflected on the Form 43 are from 0.1 to 0.5 percent. However, the Contractor should anticipate the AC increases typical of his mixes. Contractors bidding the project should anticipate this change and factor it into their unit price bid.

Asphalt cement used in Hot Mix Asphalt (Patching) will not be measured and paid for separately, but shall be included in the work.

5
REVISION OF SECTION 403
HOT MIX ASPHALT

Excavation and preparation of areas to be patched will not be measured and paid for separately, but shall be included in the work.

Tack Coat will not be paid for separately but shall be considered incidental to the project.

Temporary asphalt installation and removal required for sanitary sewer, waterline, and storm sewer patches will not be paid for separately but shall be considered incidental to the project.

END OF SECTION REVISION

1
REVISION OF SECTION 506
RIPRAP

Section 506 of the Standard Specifications is hereby revised for this project as follows:

Delete Subsection 506.04 and replace with the following:

The Contractor shall collect the scale ticket on each load of riprap when it is delivered to the project site. Measurement for riprap will be based on the weight tickets.

Delete Subsection 506.05 and replace with the following:

Excavation for the installation of Riprap shall be considered incidental to the work and will not be paid for.

Payment will be made under:

Pay Item	Pay Unit
Riprap (12 inch)	CY

END OF SECTION REVISION

1
REVISION OF SECTION 514
PEDESTRIAN AND BIKEWAY RAILING

Section 514 of the Standard Specifications is hereby revised for this project as follows:

Section 514.03 shall include the following:

Railing shall be coated with a three-layer coating system consisting of zinc rich primer, an epoxy intermediate coat, and a fluoropolymer finish coat. Coating shall be applied in a controlled environment, not in the field. Color shall be semi-gloss black. At least four weeks prior to coating the railings, the contractor shall submit two color samples for the Owner's approval. The Owner will either approve the color for use on the last section, or shall be entitled to order a change in the color, and request additional coating samples. All color samples shall be submitted on a 6"x6"x1/8" steel plate.

The contractor shall fabricate and submit a full-scale section of the railing for approval by the Owner after the review of the shop drawings. The test section shall be submitted at least four weeks in advance of the start of fabrication. The Owner may order changes to the fabrication if the results observed in the test section are unacceptable. The last section shall not be installed on the project unless it is accepted. Otherwise, the rejected sample shall be returned to the contractor for correction or disposal.

If rust or rust bleeding occurs on the railing at any time prior to the final inspection, by any reason, the contractor shall remove the rusted section and completely clean the section of all paint and primer, and completely re-prime and re-paint the entire section at no additional cost to the project.

Section 514.06 shall include the following:

Working drawings are required to be submitted in accordance with Sections 101 and 105 for all railing on this project.

Stainless steel anchor bolts shall be long enough to protrude between 0.5 and 1.0 inches above the nut after installation of the railing base plate, washer and nut.

Subsection 514.08 shall include the following:

Payment will be made under:

Pay Item	Pay Unit
Pedestrian Railing (52 Inch)	Linear Foot

END OF SECTION REVISION

1
REVISION OF SECTION 601
STRUCTURAL CONCRETE

Section 601 of the Standard Specifications is hereby revised for this project as follows:

Delete subsection 601.19 and replace with the following:

Concrete of the various classes will not be measured but will be the quantities shown on the plans. Exceptions for each structure will be:

- (1) when field changes are ordered, or
- (2) when it is determined that there are discrepancies on the plans in an amount plus or minus 2 percent of the plan quantity for the structure.

Reinforcing steel shall not be measured and paid for separately but shall be included in the work.

Subsection 601.20 shall include the following:

Reinforcing steel shall not be measured and paid for separately but shall be included in the work.

Concrete shall not be measured and paid for separately but shall be included in the work.



END OF SECTION REVISION

1
REVISION OF SECTION 602
REINFORCING STEEL

Section 602 of the Standard Specifications is hereby revised as follows:

Subsection 602.07 is replaced with the following:

602.07 Reinforcing steel will not be measured.

Subsection 602.08 is replaced with the following:

602.08 Reinforcing Steel for concrete structures will not be measured and paid for separately but shall be considered as incidental to the individual concrete structures listed on the bid schedule.

END OF SECTION REVISION

1
**REVISION OF SECTION 603
CULVERTS AND SEWERS**

Section 603 of the Standard Specifications is hereby revised for this project as follows:

Subsection 603.01 shall include the following:

The City of Thornton's Standard specification, "SECTION 400 – STORM DRAINAGE DESIGN, GRADING, AND WATER QUALITY", shall control the work required for the installation of storm sewers. The specifications are included in Appendix B at the end of these project special provisions.

The Contractor shall install protection around the work site where pipe is being installed to secure excavation for culverts and sewers. Protection shall be adequate to keep the traffic, pedestrians, and cyclists from accidentally entering trenches.

Subsection 603.02 shall include the following:

Materials furnished shall be new and undamaged. Everything necessary to complete installations shall be furnished and installed whether shown on approved drawings or not and installations shall be completed and fully operational.

Acceptance of materials or the waiving of inspection thereof shall in no way relieve the Contractor of the responsibility for furnishing materials meeting the requirements of the specifications.

Materials delivered to the job site shall be adequately housed and protected so as to ensure the preservation of their quality and fitness for the work.

Steel casing pipe for sanitary sewer relocation shall be fully coated with bituminous material conforming to the requirements of AASHTO M 190, Type-A coating or materials conforming to the requirements of AASHTO M 243, except that the use of tar base material will not be permitted. Coating shall be shop applied. The finished coat shall uniformly cover the surface to be protected. The coating shall not contain any visible holidays, bubbles or bare spots. Minimum thickness shall be 1.3 mm (50 mils). In complying with AASHTO M 190, each section shall be given a double dip application. In the first immersion, the section shall remain submerged until the metal has reached a temperature that will allow the hot bituminous material to penetrate and seal each joint. Other coatings meeting the requirements of AASHTO M 190 or M 243 will be acceptable upon written approval by the Engineer. Material meeting the requirements of AASHTO M 243 shall be uniformly applied by spray, trowel, or brush to the entire designated surface to be coated, to minimum thickness of 1.3 mm (50 mils). The coating shall be dry to the touch prior to any handling or backfilling operations.

Subsection 603.03 shall include the following:

During construction, care must be taken to avoid any ground water, storm water, construction debris, soil, or any other foreign materials from entering any active City of Thornton storm sewer. The use of sanitary sewer or storm sewer systems for the purposes of dewatering is strictly prohibited.

2

**REVISION OF SECTION 603
CULVERTS AND SEWERS**

Subsection 603.05 shall be replaced with the following:

Bedding shall be as shown on the plans.

Subsection 603.05 shall be replaced with the following:

All storm sewer joints and jointing material shall conform to the following minimum requirements:

- Rubber gasket joints for tongue and groove or bell and spigot pipe using a confined gasket joint shall consist of an o-ring rubber gasket or other approved gasket configuration and shall conform to the requirements of ASTM 361, ASTM C443, ASTM C1619, or ASTM C1628 for the pipe designated. Unless otherwise approved by the engineer, the standard joint configuration shall be as shown in the following table.
- Rubber gasket joints for tongue and groove or bell and spigot pipe using a single offset joint shall consist of a non-circular groove rubber gasket or other approved gasket configuration and shall conform to the requirements of ASTM C76 or ASTM 361 for the pipe designated. Unless otherwise approved by the engineer, the standard joint configuration shall be as shown in the following table.

3
REVISION OF SECTION 603
CULVERTS AND SEWERS

- Gaskets may be natural rubber, isoprene or neoprene conforming to ASTM C1619.

Allowable Type of Joints				
Application	Tongue and Groove with Flexible Plastic Sealing Compound	Bell and Spigot (Single Offset) (ASTM 1628 or ASTM C443)	Bell and Spigot with USBR M-1 Type R-4 Joint (Confined Gasket) (ASTM C361)	Bell and Spigot with USBR M-1 Type R-2 Joint
1. Non-Pressurized Storm Sewers				
a. Open Cut 36" & larger		X	X	
b. Open Cut 15" to 33"	X	X	X	X
c. Jack or Bored/ Cased			X	X
2. Pressurized Storm Sewers				
a. Open Cut			X	X
b. Jack or Bored/ Cased			X	X
3. Pressurized and Non-Pressurized Sanitary Sewers				
a. Open Cut			X	X
b. Jack or Bored/ Cased			X	X
<p>NOTES:</p> <p>1) Where more than one type of joint is acceptable, CONTRACTOR may use either type subject to the physical characteristics and manufacturing method of the pipe and approval of ENGINEER.</p> <p>2) All elliptical pipe or arch pipe shall be double gasketed, or per ASTM C443</p> <p>3) In addition to the gasket requirements, if the average joint gap in 36-inch diameter pipe or larger pipe exceeds 3/4-inch, the void shall be filled and troweled smooth with an approved non-metallic, non-shrink grout conforming to ASTM C827 or a flexible plastic sealant conforming to ASTM C990 so to provide a smooth interior surface at the joint.</p> <p>4) For pipe sizes 18-, 24-, 30-, and 36-inch in diameter, the reinforcement in the bell and spigot shall conform to ASTM C76 for the class of pipe specified or to ASTM C361 for a minimum pressure head of 25 feet.</p>				

Subsection 603.05 shall include the following:

Utility Trench Backfill: Materials excavated from the utility trenches may be used for trench backfill above the pipe bedding provided they are; not frozen, do not contain unsuitable material or particles larger than 4 inches, and can be placed and compacted as recommended herein.

Delete Subsection 603.12 and replace with the following:

4

**REVISION OF SECTION 603
CULVERTS AND SEWERS**

Water control and dewatering required to install storm sewer pipe, ditch culverts, inlets, and manholes shall be considered incidental to the applicable bid items being installed. All work shall be completed in dry conditions.

Conduit used for culverts storm drains of the different types and sizes will not be measured but will be the net length of pipe called for on the plans, except when field changes are ordered or when there are errors on the plans. In case of exceptions, the quantity to be measured shall be the actual net length of conduit measured along the bottom centerline. Extra length of conduit due to joint creep will not be measured and paid for.

Delete Subsection 603.13 and replace with the following:

The accepted quantities will be paid for at the contract unit price for each of the pay items listed below that appear in the bid schedule. Except as otherwise indicated on the plans or in

the special provisions, all joints, elbows, concrete collars, connecting bands and other connecting devices will not be paid for separately but shall be included in the work.

Trench protection and shoring will not be paid for separately but shall be considered incidental the unit price bid for culverts and sewers

Payment will be made under:

Pay Item	Pay Unit
8 Inch PVC SDR 35	Linear Foot
18 Inch Bituminous Coated Steel Casing Pipe	Linear Foot
24 Inch PVC C900	Linear Foot
18 Inch CL-III Reinforced Concrete Pipe	Linear Foot
24 Inch CL-III Reinforced Concrete Pipe	Linear Foot
72 Inch CL-III Reinforced Concrete Pipe	Linear Foot
5'(H)x7'(W) Reinforced Concrete Box Culvert	Linear Foot
5'(H)x16'(W) Reinforced Concrete Box Culvert	Linear Foot

Payment for PVC Pipe, Reinforced Concrete Pipe, and Reinforced Concrete Box Culverts shall be full compensation for all work necessary to complete the bid item including, but not limited to water control and dewatering, structure excavation, structure backfill, bedding, stabilization material, joints, elbows, concrete collars, reinforced concrete caps, connecting

bands, other connecting devices, and disposal of excess excavated material. Excavation and backfill will not be measured and paid for separately, but shall be included in the work

Concrete pipe joint fasteners, required on all end sections, will not be measured and paid for separately, but shall be included in the work.

5
REVISION OF SECTION 603
CULVERTS AND SEWERS

Temporary asphalt installation and removal required for sanitary sewer, waterline, and storm sewer patches will not be paid for separately but shall be considered incidental to the project.

END OF SECTION REVISION

1

**REVISION OF SECTION 614
TRAFFIC CONTROL DEVICES**

Section 614 of the Standard Specifications is hereby revised for this project as follows:

Section 614.13 replaced with the following:

Traffic control devices required for roadway closure and detour will not be measured separately but shall be considered incidental to the Lump Sum Price for traffic control.

END OF SECTION REVISION

1

**REVISION OF SECTION 625
CONSTRUCTION SURVEYING**

Section 625 of the Standard Specifications is hereby revised for this project as follows:

Subsection 625.11 shall include the following:

All survey records generated shall be the property of the City of Thornton.

Upon completion of construction, new property pins associated with the Project shall be set indicating the new property corners and/or Right-of-way line.

Setting of new property pins will not be measured and paid for separately but will be included in the work.

Subsection 625.13 shall include the following:

Before granting Initial Acceptance, the following items shall be completed, reviewed and approved by the Engineer:

1. Verification that all Monuments and Stakes have been reset in accordance with sub-section 625.08
2. All Survey Records in accordance with sub-section 625.11

END OF SECTION

1

**REVISION OF SECTION 627
PAVEMENT MARKINGS**

Section 627 is hereby revised for this project as follows:

DESCRIPTION

This Work consists of furnishing and applying pavement marking in accordance with these specifications, the Manual of Uniform Traffic Control Devices for Streets and Highways (MUTCD), the Colorado supplement, thereto, and in conformity to the lines, dimensions, patterns, locations, and details shown on the plans or established.

MATERIALS

In general, paint will not be used unless approved by the Owner. On existing pavement, Preformed Plastic Pavement Markings shall be used. On new pavement, Preformed Plastic Inlayed Pavement Markings shall be used.

1. Preformed Plastic Pavement Markings and Legends

A. General

1. The prefabricated markings described shall consist of white or yellow pigmented plastic films with reflective glass spheres, uniformly distributed throughout their entire cross-sectional area, and shall be capable of being affixed to bituminous or Portland cement concrete pavements by either a pressure sensitive precoated adhesive or a liquid contact cement. The markings shall be provided in complete, a form that shall facilitate rapid application and protect the markings in shipment and storage. The contractor shall use proper solvents and/or adhesives for application, all equipment necessary for proper application, and recommendations for application that shall assure an effective performance life. The marking film shall have resealing characteristics such that it shall fuse with itself and with previously applied marking materials of the same composition under normal conditions of use.
2. Prefabricated legends and symbols shall conform to the applicable shapes and sizes as outlined in the MUTCD.

B. Classification

The markings shall be highly durable retroreflective pliant polymer materials, designed for longitudinal and word/symbol markings subjected to high traffic columns and severe wear conditions, such as shear action from crossover, or encroachment on typical longitudinal configurations such as edge lines, barrier lines and lane lines.

- C. Symbols, legends, long lines, skips, stop bars and crosswalks shall be 3M Series 270 ES or approved equal. For concrete pavement, long lines and skips shall be 3M Series 380I-5ES or approved equal.

2

**REVISION OF SECTION 627
PAVEMENT MARKINGS**

2. Marking Paint

Marking paint generally will not be approved for permanent markings. The use of pure acrylic high solids for hot application and quick dry to paint centerlines and edge lines on roads, crosswalks, stop zones, parking lots, storage zones, aisles, etc. as approved by the City of Thornton Project Manager shall contain no lead and comply with the EPA's voluntary 30/50 program, and meet the performance standards of federal specifications TT-P-1952. Prior to application, surfaces must be thoroughly dry and free from dirt, loose paint, oil, grease, and other contaminants. Paint may be thinned if necessary up to two (2)%, thin per manufacturer's recommendation. The paint shall be applied at air, surface, and product temperature above 50° F or per manufacturer's specifications.

% solids by weight	77.5 +/- 3%
Viscosity	80 - 90 K.U.
Sheen	Flat
Wet film per coat	14 – 16 mils
Dry film per coat	8.4 – 9.6 mils
Application rate	1 gal / 100 sf
Unit weight	14 lbs. / gal

3. Thermoplastic Marking

A. Shall be in conformance with CDOT SSRBC Section 713.12.

4. Reflectorized Glass Beads

A. A blended material consisting of spheres containing refractive indices of 1.50 and 1.65 and conforming to the following specifications:

1. Manufactured from high grade optical crown glass of a composition designed to be highly resistant to traffic wear and to the effects of weathering.
2. Colorless, clean and transparent.

B. Material

The reflectorizing glass beads shall conform to the following:

1. Refracture Index - When testing by the liquid immersion method at 77° F, 70% of the spheres shall have an average index of not less than 1.50, and 30% shall have an average index of not less than 1.65.

3
REVISION OF SECTION 627
PAVEMENT MARKINGS

1.50 Index Glass Beads

U.S. Standard Sieve Number	% Passing by Weight
20	95 – 100
30	75 - 95
50	9 - 32
80	0 - 15

1.65 Index Glass Beads

U.S. Standard Sieve Number	% Passing by Weight
50	100
80	90 – 100
100	75 - 90
200	0 - 5

CONSTRUCTION REQUIREMENTS

The contractor shall field layout pavement markings for installation, via chalk or paint lines, for approval of owner prior to installation of material. Permanent pavement markings shall have an epoxy binder applied and be tape unless another material is approved in writing by the Traffic Engineer.

Pavement markings shall be so applied as to assure continuous uniformity in the dimensions of the stripe.

Laydown tolerances for each pavement marking shall be one (1) inch longitudinally and one quarter (1/4)-inch transversely.

Permanent pavement markings installed on new asphalt shall be inlaid and installed within four (4) hours of placement of the final lift of asphalt pavement. Pavement markings on existing and new concrete pavement shall be recessed in a one fourth ($\frac{1}{4}$) inch groove not to exceed one half ($\frac{1}{2}$) inch wider nor two (2) inches longer than the tape being laid and shall be glued with an epoxy binder. Permanent pavement markings on existing asphalt shall have an epoxy binder applied and be tape.

The pavement marking shall be applied to the pavement either to the right or left of the application unit, dependent upon roadway lane being used. The unit shall not occupy more than one lane of roadway while operating.

4

**REVISION OF SECTION 627
PAVEMENT MARKINGS**

The finished lines shall have well defined edges and be free of waviness. Tolerance shall be one (1) inch longitudinally and one fourth ($\frac{1}{4}$) inch transversely. The minimum thickness of thermoplastic line shall be three thirty-seconds ($\frac{3}{32}$) inch at the edges, not less than one eighth ($\frac{1}{8}$) inch at the center. Measurements shall be taken as an average throughout any 10-foot section of the line. The material, when formed into traffic stripes, must be readily renewable by placing an overlay of new material directly over an old line of compatible material. Such new material shall bond itself to the old line in such a manner that no splitting or separation takes place. All of the equipment necessary to the preheating and application of the material shall be so designed that the temperature of the material can be controlled within the limits necessary to its pourability for good application.

The marking material as specified shall be installed at the manufacturer's recommended temperature.

At the time of installation of thermoplastic materials, the pavement shall be clean, dry, and free of laitance, oil, dirt, grease, paint, or other foreign contaminants. Pavement and ambient temperatures shall be at least 50° F.

An epoxy resin primer shall be applied to concrete surfaces prior to the application of the thermoplastic pavement marking. The epoxy resin primer shall be installed per the thermoplastic manufacturer recommendations.

The marking material shall not be applied until the epoxy resin primer reaches the tacky stage. An infrared heating device may be employed to shorten the curing time of the epoxy.

If the City of Thornton Project Manager determines that a new asphalt surface has become soiled, prior to placement of the pavement markings, a pavement primer will be required and preformed plastic pavement markings shall be applied as approved.

The epoxy resin primer material may be accepted at the job site on the basis of a manufacturer's certification, or a sample may be sent to the laboratory for testing, in which case three (3) weeks shall be allowed between sampling and intended use.

5
REVISION OF SECTION 627
PAVEMENT MARKINGS

BASIS OF PAYMENT

Payment shall be made under:

Pay Item	Pay Unit
Preformed Plastic Pavement Marking (Type 1) (Inlaid)	Square Foot
Preformed Plastic Pavement Marking (Word-Symbol) (Type 1) (Inlaid)	Square Foot
Preformed Plastic Pavement Marking (Crosswalk-Stop Line) (Type 1) (Inlaid)	Square Foot

Removal of existing pavement markings, when required, shall be considered incidental to "Pavement Marking Paint (Low VOC Solvent Base)".

Temporary pavement markings required for traffic control shall be considered incidental to the Lump Sum Price for Traffic Control.

END OF SECTION REVISION

1

**REVISION OF SECTION 629
SURVEY MONUMENTATION**

Section 630 of the Standard Specifications is hereby revised for this project as follows:

Subsection 629.08 is deleted and replaced with the following:

Survey Monuments, Monument Boxes, and Adjust Monument Boxes will be measured by the actual number of the various types installed and accepted by the Engineer. Measurement for locating survey monuments shall be considered incidental to setting Survey Monuments.

Section 629.09 shall include the following:

Survey monumentation shall not be measured and paid for separately but shall be included in the work.

1

**REVISION OF SECTION 630
CONSTRUCTION ZONE TRAFFIC CONTROL**

Section 630 is hereby revised for this project as follows:

Section 630.17 is deleted and replaced with the following

Traffic control devices, flagging, traffic control inspection and traffic control management will not be measured. A suggested phasing plan and tabulation of traffic control devices are included on the drawings. The phasing plan is only a suggestion and the tabulations are for information only. It shall be the Contractors responsibility to prepare construction phasing plans and traffic control plans for the project.

Section 630.18 is deleted and replaced with the following

Construction traffic control will be paid for on a lump sum basis. Payment for traffic control necessary to complete the work shall be full compensation for furnishing, erecting, cleaning, maintaining, resetting, repairing, replacing, moving, removing, and disposing of the construction traffic control devices. The lump sum payment will also include flagging, traffic control inspection and traffic control management.

The lump sum bid price shall be based on the Contractor's construction phasing plans and traffic control plans.

All construction traffic control devices that are not permanently incorporated into the project will remain the property of the Contractor.

Construction traffic control as determined by the approved project Traffic Control Plan (TCP), will be paid for as follows:

<u>Contract Amount Completed</u>	<u>Traffic Control Paid</u>
Upon First Utilization	= 25%
25%	= 50%
75%	= 90%
100%	= 100%

The percent of original contract amount earned will be determined by comparing the amount earned for bid items, other than traffic control devices and mobilization, with the original contract amount minus the amounts bid for traffic control devices and mobilization.

Payment shall be made under:

Pay Item	Pay Unit
Traffic Control	Lump Sum

END OF SECTION REVISION

1

**REVISION OF SECTION 630
PORTABLE MESSAGE SIGN PANEL**

Section 630 of the Standard Specifications is hereby revised for this project as follows:

Subsection 630.01 shall include the following:

This work includes furnishing, operating, and maintaining a portable message sign panel.

Add subsection 630.031 immediately following subsection 630.03 as follows:

630.031 Portable Message Sign Panel. Portable message sign panel shall be furnished as a device fully self-contained on a portable trailer, capable of being licensed for normal highway travel, and shall include leveling and stabilization jacks. The panel shall display a minimum of three - eight-character lines. The panel shall be a dot-matrix type with an LED legend on a flat black background. LED signs shall have a pre-default message that activates before a power failure. The sign shall be solar powered with independent back-up battery power. The sign shall be capable of 360 degrees rotation and shall be able to be elevated to a height of at least five feet above the ground measured at the bottom of the sign. The sign shall be visible from one-half mile under both day and night conditions. The message shall be legible from a minimum of 750 feet. The sign shall automatically adjust its light source to meet the legibility requirements during the hours of darkness. The sign enclosure shall be weather tight and provide a clear polycarbonate front cover.

Solar powered message signs shall be capable of operating continuously for 10 days without any sun. All instrumentation and controls shall be contained in a lockable enclosure. The sign shall be capable of changing and displaying sign messages and other sign features such as flash rates, moving arrows, etc.

Each sign shall also conform to the following:

1. In addition to the onboard solar power operation with battery back-up, each sign shall be capable of operating on a hard wire, 100-110 VAC, external power source.
2. All electrical wiring, including connectors and switch controls necessary to enable all required sign functions shall be provided with each sign.
3. Each sign shall be furnished with an operating and parts manual, wiring diagrams, and trouble-shooting guide.
4. The portable message sign shall be capable of maintaining all required operations under Colorado mountain-winter weather conditions.
5. Each sign shall be furnished with an attached license plate and mounting bracket.
6. Each sign shall be wired with a 7-prong male electric plug for the brake light wiring system.

2

**REVISION OF SECTION 630
PORTABLE MESSAGE SIGN PANEL**

Subsection 630.13 shall include the following:

The portable message sign panel shall be on the project site at least 14 days prior to the start of active roadway construction. Traffic control management and traffic control inspection is required during this 14-days. Traffic control management and traffic control inspection shall be considered incidental to the lump sum price bid for Traffic Control.

Maintenance, storage, operation, relocation to different sites during the project, and all repairs of portable message sign panels shall be the responsibility of the Contractor.

Subsection 630.15 shall include the following:

Portable message sign panels required for roadway closure and detour will not be measured separately but shall be considered incidental to the Lump Sum Price for traffic control.

END OF SECTION REVISION

1

**REVISION OF SECTION 716
WATER LINE MATERIALS (SLUDGE LINE)**

Section 716.05 is hereby revised for this project as follows:

Section 716.05 is deleted and replaced with the following

PRODUCTS

1.1 PIPING MATERIALS

A. PVC Pipe and Fittings

1. PVC, AWWA Pipe: AWWA C900, **Class 200**, with bell end with gasket and spigot end.
 - a. Push-on-Joint, Ductile-Iron Fittings: AWWA C110, pressure rating 250 psi, ductile-iron or gray-iron standard pattern or AWWA C153, ductile-iron compact pattern.
 - 1) Gaskets: AWWA C111, rubber.
 - 2) Cement mortar lined, AWWA C104.
 - 3) Bituminous coating 1 mil thick.
 - b. Mechanical-Joint, Ductile-Iron Fittings: AWWA C110, ductile- or gray-iron standard pattern or AWWA C153, ductile-iron compact pattern.
 - 1) Glands, Gaskets, and Bolts: AWWA C111, ductile- or gray-iron glands, rubber gaskets, and steel bolts.

B. Mechanical Joint Restraint

1. General: All mechanical joint restraints shall be incorporated in the design of a follower gland. The gland shall be manufactured of ductile iron conforming to ASTM A536. Dimensions of the gland shall be such that it can be used with the standardized mechanical joint bell and tee-head bolts conforming to AWWA C111 and ASTM C153.
2. Description: The restraint mechanism shall consist of numerous individually activated gripping surfaces to maximize restraint capability. The gripping surfaces shall be wedges designed to spread the bearing surfaces on the pipe. Twist-off nuts, sized same as tee-head bolts, shall be used to insure proper actuating of restraining devices. When the nut is sheared off, a standard hex nut shall remain.
3. Pressure: The mechanical joint restraint device for ductile iron pipe shall have a working pressure of at least 250 psi with a minimum safety factor of 2.
4. The mechanical joint restraint device for PVC shall have a working pressure of at least 150 psi with a minimum safety factor of 2:1.
5. Acceptable Manufacturer: The mechanical joint restraint devices shall be of the type listed below or equal, and approved by **agency having jurisdiction** prior to bidding:

2

**REVISION OF SECTION 716
WATER LINE MATERIALS (SLUDGE LINE)**

For Ductile Iron Pipe:

EBAA Iron, Inc.	Megalug 1100 series	(4 inches to 36 inches)
Uni-Flange	Series 1400	(4 inches to 36 inches)

PART 2 - EXECUTION

2.1 EARTH MOVING

- A. **Exploratory Excavation:** It shall be the Contractor's responsibility to excavate and locate all existing utilities which may affect construction of the water facilities. All exploratory excavations shall occur far enough in advance to permit any necessary relocation to be made with minimum delay and to verify existing vertical and horizontal location to determine alignment for the proposed water line. All costs incurred by the Contractor in making exploratory excavations shall be considered to be included in the unit price bid for constructing each section of water line or the associate structures.

B. **Unstable Trench Bottom**

Where trench does not have sufficient strength to support pipe and bedding, or stream crossings are encountered, use one of following methods to repair trench bottom, as approved by the Engineer. A minimum depth of repair is 2 feet.

1. **Embankment:** Clear and strip existing surface of all unacceptable material. Place embankment material agreed to by the Engineer, compact to 95 percent AASHTO T99.
2. **Aggregate Trench Bottom,** percent by weight passing square mesh sieves: 1-1/2-inch, 90 100; 3/4-inch, 50 90; No. 4, 30 50; No. 200, 3 12.

2.2 PIPING APPLICATIONS

- A. **General:** Use pipe, fittings, and joining methods for piping systems according to the following applications.
- B. **Transition couplings and special fittings** with pressure ratings at least equal to piping pressure rating may be used in applications below, unless otherwise indicated.
- C. **Do not use flanges, unions, or keyed couplings** for underground piping.
- D. **Flanges, unions, keyed couplings, and special fittings** may be used, instead of joints indicated, on aboveground piping and piping in vaults.

2.3 JOINT CONSTRUCTION

- A. **Make pipe joints** according to the following:
1. **PVC Piping Gasketed Joints:** Use joining materials according to AWWA C900. Construct joints with elastomeric seals and lubricant according to ASTM D 2774 or ASTM D 3139 and pipe manufacturer's written instructions.

3

**REVISION OF SECTION 716
WATER LINE MATERIALS (SLUDGE LINE)**

2. Dissimilar Materials Piping Joints: Use adapters compatible with both piping materials, with OD, and with system working pressure.

B. Pipe Jointing:

1. General: Cut pipe for inserting valves, fittings, or closure pieces in neat and workmanlike manner with no damage to pipe or lining. Leave smooth end at right angles to axis of pipe.
2. Mechanical Joints: Thoroughly clean last 8 inches of spigot and inside bell to remove oil, grit, tar, and other foreign matter. Coat spigot and gasket with solution furnished by pipe manufacturer. Slip cast-iron gland on spigot end of pipe with lip extension of gland toward spigot end. Coat gasket with joint lubricant and place on spigot end of pipe to be laid, with thick edge toward gland.

Push entire section forward to seat spigot in bell of pipe in place. Press gasket into place within bell, even around entire joint. Move ductile-iron gland along pipe into position for bolting all nuts with suitable torque wrench. Alternately tighten nuts 180 degrees apart to produce equal pressure on all parts of gland.

Pipe Size Inches	Bolt Size Inches	Range of Torque Ft.-Lb.
3"	5/8	45 - 60
4" to 24"	3/4	75 - 90

3. Push-on Joints: Thoroughly clean exterior 4 inches of pipe spigot and inside of adjoining bell to remove all oil, grit, tar, and other matter. Place gasket in bell with large round side of gasket pointing inside pipe bell. Apply thin film joint lubricant over gasket's entire exposed surface. Wipe spigot end of pipe clean and insert into bell to contact gasket. Force pipe into bell to manufacturer's jointing mark.
4. Flanged Joints: Thoroughly clean faces of flanges of all oil, grease, and other material. Thoroughly clean rubber gaskets and check for proper fit. Assure proper seating of flanged gasket. Tighten bolts so pressure on gasket is uniform. Use torque wrenches to insure uniform bearing. If joints leak when hydrostatic test applied, remove and replace gaskets and retighten bolts.

2.4 PIPING INSTALLATION

- A. General: Deliver, handle, store, and install in accordance with the pipe manufacturer's recommendations and the applicable paragraphs of AWWA C600, AWWA C603, and ASTM D2321.

Carefully examine all pipe and fittings for cracks and other defects. Groove in bells of ductile iron pipe to be full and continuous or be rejected. Remove all foreign matter from interior and ends of pipe and appurtenances before lowering into trench. Carefully lower all pipe, fittings, valves, and hydrants into trench piece by piece to prevent damage to pipe materials, protective coatings, and linings. Do not dump into trench. If pipe cannot be lowered into trench and into

4

**REVISION OF SECTION 716
WATER LINE MATERIALS (SLUDGE LINE)**

place without getting earth into it, place heavy, tightly woven canvas bag over each end and leave in place until joints are made. During pipe laying, place no debris, tools, clothing, or other materials in pipe.

Keep trenches free from water during pipe laying and jointing. Dewatering of trench considered as incidental to construction and all costs included in contract prices. When pipe laying is not in progress, close open ends of pipe by watertight plug, or other means approved by the Engineer.

Dewatering shall be accomplished by the use of well points, sump pumps, rock or gravel drains placed below subgrade foundations, or subsurface pipe drains. All water shall be disposed of in a suitable manner without being a menace to public health or causing public inconvenience. No water shall be drained into other work being completed or under construction. Obtain all necessary permits for dewatering.

The dewatering operation shall continue until such time as it is safe to allow the water table to rise in the excavations. Pipe trenches shall contain enough backfill to prevent pipe floatation.

Water shall not be allowed to rise until the concrete has set a minimum of 24 hours, and the forms have been removed. Water shall not be allowed to rise unequally against unsupported structural walls.

- B. Deflection of Pipe: Do not exceed deflection limits for each type of pipe as recommended by the pipe manufacturer. Typical values are:

1. Ductile Iron: Length = 18 Feet

Maximum Deflections in Feet

Pipe Size in Inches	3	4	6	8	10	12
Bell – Tite	1.57					1.57
Mechanical Joint	2.60		2.23	1.68		
Locked Mechanical Joint	0.94	0.86	0.63	0.47	0.39	0.30
Super Lock				1.26		
River Cross				4.66		

- C. Install PVC, AWWA pipe according to AWWA M23 and ASTM F 645.
- D. Install underground piping with restrained joints at horizontal and vertical changes in direction. Use restrained-joint piping.

2.5 UTILITIES ENCOUNTERED

- A. Protection of all existing gas, water, sewer services, drains, cable, telephone lines, and electric lines encountered during construction is the Contractor's responsibility. If utilities are disturbed, they shall be maintained and/or restored to original condition at the Contractor's expense. Backfill around utilities shall be adequately compacted to assure permanent stability.

5

**REVISION OF SECTION 716
WATER LINE MATERIALS (SLUDGE LINE)**

2.6 FIELD QUALITY CONTROL

- A. Piping Tests: Conduct piping tests before joints are covered. Fill pipeline 24 hours before testing and apply test pressure to stabilize system. Use only potable water.
- B. Notify Engineer at least 24 hours in advance of pipe being laid in any trench. Cover no pipes until observed by the Engineer. Notify the Engineer at least 48 hours before pipe is to be tested. All water mains are to be disinfected, flushed, and hydrostatically tested per **agency having jurisdiction**.
- C. Hydrostatic Testing:
1. General: Make pressure and leakage tests on all newly laid pipe. Test two or more valved sections not to exceed 1,000 feet. Test first section of pipe laid to verify if watertight. Lay no additional pipe until first test section has passed tests.
 2. Furnish following equipment and materials for tests, unless otherwise directed by the Engineer:
 - 1 Graduated containers
 - 2 Pressure gauges
 - 1 Suitable hose and suction pipe as required
 3. Testing Procedure: Test each 1,000 feet of line installed while trench is partially backfilled and joints are left exposed for examination for leaks. Do not conduct pressure tests until 48 hours after placement of concrete thrust blocks. After pipe has been partially backfilled, slowly let water into line. Vent to allow air in line to be released. Flush line as necessary for cleaning. Leave water in line for 24 hours prior to pressure test. Test at one and a half times working pressure, calculated for low point of test section, or 150 psi, whichever is greater. Valve off pump and hold pressure in line for test. Test for two hours or as agreed to by the Engineer. At end of test, operate pump until test pressure is again attained. Calibrate container of water for pump suction to determine amount of water to replace leakage.
 4. Leakage Allowance: Leakage is quantity of water necessary to refill line at end of test period. No installation will be accepted until leakage is less than:

ALLOWABLE LEAKAGE PER 1,000 FEET OF PIPE IN GPH

Avg. Test	Nominal Pipe Diameter - in. Pressure					
	6	8	10	12	18	
200	0.64	0.85		1.06	1.28	1.91
175	0.59	0.80		0.99	1.19	1.79
150	0.55	0.74		0.92	1.10	1.66
125	0.50	0.67		0.84	1.01	1.51
100	0.45	0.60		0.75	0.90	1.35

For pipe with 18 feet nominal lengths. To obtain recommended allowable leakage for pipe with 20 feet nominal lengths, multiply the leakage calculated from the table by 0.9.

6

**REVISION OF SECTION 716
WATER LINE MATERIALS (SLUDGE LINE)**

If pipeline under test contains sections of various diameters, allowable leakage will be sum of computed leakage for each size. Reduce allowable leakage proportionately for sections less than 1,000 feet.

- D. Prepare reports of testing activities.

2.7 FLUSHING AND DISINFECTING

- A. General: In accordance with AWWA C601. Acceptable chlorine disinfectants are calcium hypochlorite granules, sodium hypochlorite solutions, and calcium hypochlorite tablets.
- B. Chlorine-Water Solution Method:

Chlorine Required to Produce 25 Mg/L Concentration
in 100 feet of Pipe - by Diameter

Pipe Diameter In.	100 Percent Chlorine Lb.	1 Percent Chlorine Solution Gal.
4	.013	.16
6	.030	.36
8	.054	.65
10	.085	1.02
12	.120	1.44
16	.217	2.60

Induce chlorine solution into pipe line at a continuous feed rate to attain a concentration of 25 Mg/L free chlorine.

- C. Tablet Method: May not be used on solvent welded plastic pipe. May be used only when all foreign materials have been kept out of pipe. If ground water has entered pipe during installation and tablets have been installed, flush main and use chlorine-water solution method. Do not use if temperature is below 5 degrees C. Place tablets with non-toxic adhesive in each pipe length in top of pipe in accordance with following table:

7

**REVISION OF SECTION 716
WATER LINE MATERIALS (SLUDGE LINE)**

Number of 5-g Hypochlorite Tablets
Required for Dose of 25 mg/L*

Pipe Diameter in.	Length of Pipe Section, ft.				
	13 or less	18	20	30	40
4	1	1	1	1	1
6	1	1	1	2	2
8	1	2	2	3	4
10	2	3	3	4	5
12	3	4	4	6	7
16	4	6	7	10	13

- D. Chlorination Test: Assure valves are closed on existing system to prevent chlorine solution flowing into existing system. Retain 25 mg/L chlorinated water in pipe line for minimum of 24 hours. During retention period operate all valves and hydrants to disinfect. At end of 24 hour period, chlorine in system to be no less than 10 mg/L throughout length tested. When section being tested meets 10 mg/L chlorine after 24 hours, flush main. Water samples taken shall show no coliform organisms. If water in pipe does not meet the governing health agency requirements, repeat disinfection procedure, at the Contractor’s expense, until requirements are met. Furnish acceptance forms from governing agency to the Engineer.

2.8 IDENTIFICATION

- A. Install continuous underground detectable warning tape during backfilling of trench for underground water-service piping. Locate below finished grade, directly over piping. See Division 31, Section “Trenching and Backfilling” for underground warning tapes.

2.9 CLEANUP AND RESTORATION

- A. Restore all pavements, curbs, gutters, utilities, fences, irrigation ditches, yards, lawns, and other structures or surfaces to condition equal to or better than before work began, and to satisfaction of the Engineer. Deposit all waste material in designated waste areas. Grade and shape disposal site. Complete topsoil and reseeded of site, if required. Where disposal sites are not designated, remove, and dispose of all waste material off-site.

Payment shall be made under:

Pay Item	Pay Unit
24 Inch PVC Pipe (Restrained)	Linear Foot
24 Inch PVC Pipe (Unrestrained)	Linear Foot

END OF SECTION REVISION

1

TRAFFIC CONTROL PLAN - GENERAL

The key elements of the Contractor's method of handling traffic (MHT) are outlined in subsection 630.10(a). The components of the TCP for this project are included in the following:

- (1) Subsection 104.04 and Section 630 of the specifications.
- (2) Standard Plan S-630-1, Traffic Controls for Highway Construction, and Standard Plan S-630-2.
- (3) Schedule of Construction Traffic Control Devices (provided for information only).
- (4) Signing Plans
- (5) Construction Phasing Plans and Details (provided for information only).

The Contractor shall provide, erect and maintain proper traffic control devices until the site is open to traffic. The Contractor shall submit a traffic control plan to the City of Thornton for approval prior to construction. Traffic control shall also include safety and control of pedestrians and bicyclists on the sidewalks and trails in and around the project site.

Unless otherwise approved by the Engineer, the Contractor's equipment shall follow normal and legal traffic movements. The Contractor's ingress and egress of the work area shall be accomplished with as little disruption to traffic as possible. Traffic control devices shall be removed by picking up the devices in a reverse sequence to that used for installation. This may require moving backwards through the work zone. When located behind barrier or at other locations shown on approved traffic control plans, equipment may operate in a direction opposite to adjacent traffic.

The responsibility under the Contract for all traffic control resides with the Contractor and any participation by law enforcement personnel in Contractor traffic control activities will be referenced in either the Special Provisions or General Notes of the plans. Nothing in this Contract is intended to create an entitlement, on the part of the Contractor, to the services or participation of the law enforcement organization.

The Contractor shall be responsible for the provision of a safe travel way on all streets, roadways sidewalks, and trails on and adjacent to the job site. The Contractor shall erect or cause erection of proper traffic control warning devices around all excavations, embankments, and obstructions and shall be responsible for the proper maintenance of said erected devices, in accordance with the traffic control permit and the MUTCD.

The Contractor shall cause suitable warning lights to be provided and kept lighted at night or other times when visibility is limited. The Contractor shall provide flaggers and/or off-duty police protection as may be determined by the City of Thornton Project Manager for the protection of the public, as well as workers on the job site.

The Contractor shall coordinate with the Traffic Engineer so that arrangements may be made by the Contractor for detours, parking, and access to property adjacent to work, etc., 48 hours prior to their need. A minimum notification of one (1) week is required when detouring a street.

2

TRAFFIC CONTROL PLAN – GENERAL

The Contractor shall not work within any portion of a street without receiving a Traffic Control Permit from the Traffic Engineer prior to such work. At the direction of the City of Thornton, a full roadway closure will be required for the construction of the proposed improvements. Requirements for such closures will be determined at the time of issuance of permit. The Contractor will be responsible for all public notices, public meetings, and requirements as outlined in the Traffic Control Permit.

The Contractor shall be responsible for all damages to the work due to failure to place barricades, signs, lights, flaggers, and other workers to protect it. Whenever evidence of such damage is found prior to acceptance, the Traffic Engineer may order the damaged portion immediately removed and replaced by the Contractor.

Except in cases of emergency, maintenance, or protection of work already completed, no work shall be allowed between the hours of 7 p.m. and 7 a.m.; nor on Saturday, Sunday, or legal holidays unless approved by Infrastructure Engineering in each case. When any inspector is required to work outside the hours of 7 a.m. to 4 p.m. on regular City business days, overtime shall be charged to the Contractor. However, such Inspectors shall remain employees of the City for all purposes. Requests for overtime shall be made to Infrastructure Engineering at least 48 hours in advance. Payment for such overtime work shall be made to the City prior to final acceptance.

All costs incidental to the foregoing requirements shall be included in the original contract price for Traffic control.

END OF SECTION REVISION

1
UTILITIES

Known utilities within the limits of this project are:

UTILITY / ADDRESS	CONTACT / EMAIL	PHONE
Xcel Energy – Electric Represented by: UC Synergetic 555 Zang St. Ste 250 Lakewood CO 80228	Branda Sloan Branda.L.Sloan@xcelenergy.com	(303) 628-2276 (720) 354-2000 cell
Xcel Energy – Gas Transmission 1123 W. 3 rd Avenue, 2 nd Floor Denver, CO 80223	Sarah Robinson, PE Sarah.Robinson@XCELENERGY.COM	(303) 571-3296 (303) 517-6099 cell
Century Link 5325 Zuni Street Denver, CO 80221	Nicole Frank Nicole.Frank@centurylink.com	(720) 578-3714 (303) 514-6331 cell
Comcast Cable 8000 E. Iliff Avenue Denver, CO 80231	Kip West Kip_West@comcast.com	(303) 603-2832 (303) 347-9992 cell
City of Thornton Traffic Engineering 12450 Washington Street Thornton, CO 80241	Edward Sanchez edward.sanchez@thorntonco.gov	(720) 977-6477

The work described in these plans and specifications requires coordination between the Contractor and the utility companies in accordance with the City's General Conditions in conducting their respective operations as necessary to complete the utility work with minimum delay to the project.

The work listed below shall be performed by the Contractor in accordance with the plans and specifications, and as directed by the Engineer. The Contractor shall keep each utility company advised of any work being done to its facility, so that the utility company can coordinate its inspections for final acceptance of the work with the Engineer.

The Contractor shall contact Xcel Energy Builder's Call Line at (1-800-628-2121) 30 days in advance of requiring connection to power sources to allow Xcel Energy adequate time for administration and processing of the new street lighting and billing. The Contractor shall be responsible for coordination of power source work to be performed by Xcel Energy. The Contractor shall contact the Xcel Energy Builder's Call Line to coordinate the power sources for both street lighting and the traffic signal as shown on the plans.

The Contractor shall anticipate abandoned gas and electric lines within the project site. The Contractor shall coordinate with Xcel Energy to locate abandoned lines. Some of the abandoned lines may not be able to be located by Xcel Energy. The Contractor shall coordinate the work so as to avoid delays caused by any abandoned utility lines. No additional payment will be made for coordinating, locating, working around, or removing abandoned utility lines. All work associated with abandoned utility lines shall be considered incidental to the project.

2 UTILITIES

The Contractor shall at times be required to work in close proximity to dry utilities such as electric lines, gas lines, telephone lines, cable television lines, and miscellaneous fiber optic lines. This work may include locating the utilities, potholing utilities, careful excavation around utilities to create slack in the lines for minor vertical adjustments, and forming walls around utilities including PVC sleeves through the wall. This work shall be coordinated with the utility companies and shall be considered incidental to the work requiring the utility adjustments.

GENERAL:

The Contractor shall comply with Article 1.5 of Title 9, CRS ("Excavation Requirements") when excavation or grading is planned in the area of underground utility facilities. The Contractor shall notify all affected utilities at least two (2) business days, not including the day of notification, prior to commencing such operations. The Contractor shall contact the Utility Notification Center of Colorado (UNCC) at (8-1-1) or 1-800-922-1987 to have locations of UNCC registered lines marked by member companies. All other underground facilities shall be located by contacting the respective company.

Utility service laterals shall also be located prior to beginning excavating or grading.

The location of utility facilities as shown on the plan and profile sheets, and herein described, were obtained from the best available information.

Unless otherwise noted. All costs incidental to the foregoing requirements will not be paid for separately but shall be included in the work.

END OF SECTION

THIS PAGE INTENTIONALLY LEFT BLANK

APPENDICES

THIS PAGE INTENTIONALLY LEFT BLANK

APPENDIX “A”

Geotechnical Engineering Study and Pavement Thickness Design, Hoffman Way Parallel
Drainage 88th Avenue to 90th Avenue, Thornton, Colorado, prepared by Kumar &
Associates, Inc., dated December 11, 2020.

APPENDIX “B”

SUBMITTALS

The Contractor shall submit for review and approval the following list of equipment and materials as required by the plans, prior to the Contractor ordering such materials. Submittals shall consist of product cut sheets and necessary supporting material and each item shall be identified by the trade name, size, and catalog number. Additional documentation may be requested at the discretion of the Traffic Engineer.

- RCP Pipe
- PVC Pipe
- Pre-Cast Concrete Box Culverts
- Pre-Cast Sanitary Access Manholes
- Hot Mix Asphalt
- Structure Reinforcing Shop Drawings
- Structural Concrete
- Pedestrian Railing
- Riprap
- Erosion Control Blanket
- Sodding
- Seed Mix
- Soil Amendment Including Compost
- Plant Material Mulch
- Pavement Markings
- Traffic Control Plan



Kumar & Associates, Inc.®
Geotechnical and Materials Engineers
and Environmental Scientists

800 Stockton Avenue, #4
Fort Collins, CO 80524
phone: (970) 416-9045
fax: (970) 416-9040

email: kaftcollins@kumarusa.com
www.kumarusa.com

An Employee Owned Company

Office Locations: Denver (HQ), Parker, Colorado Springs, Fort Collins, Glenwood Springs, and Summit County, Colorado

March 4, 2021

Martin/Martin
12499 West Colfax Avenue
Lakewood, CO 80215

ATTENTION: Mr. Logan Erf, P.E.

Subject: Addendum to Geotechnical Engineering Study, Hoffman Way Parallel Drainage, 88th Avenue to 90th Avenue, Thornton, Colorado

Project No. 20-3-151

Dear Mr. Erf:

This letter presents an addendum to the geotechnical engineering study performed for the proposed Hoffman Way Parallel Drainage, 88th Avenue to 90th Avenue, Thornton, Colorado and presented under our Project No. 20-3-151 dated June 11, 2020 and revised on December 11, 2020. We understand that elevations of foundations may extend soft soils near the groundwater level. Recommendations are provided below regarding foundation construction if the soft soils are encountered.

Based on the foundation subgrade elevations provided and the presence of soft soils near the groundwater level, we recommend soils founded near the groundwater level be improved by overexcavating a minimum of 5 feet below the foundation subgrade elevation (or into bedrock, whichever is shallower) and replacing the excavated materials with properly compacted CDOT Class 6 aggregate base course. We recommend the excavation extend a minimum of 1H : 1V outside the foundation footprint. We also recommend using a woven geosynthetic liner at the base of the excavation to prevent migration of fines into the base course material.

Footings placed on the prepared subgrade described above may be designed for a net allowable bearing pressure of 1,500 psf.

Based on our subsurface investigation, we have assumed an average design groundwater level of 7 feet below the existing grade.

All other recommendations from the original study should be followed for the project.

If you have any questions, or if we can be of further assistance, please contact us.

Sincerely,
KUMAR & ASSOCIATES, INC.

Jacob A. Hanson, P.E.
Project Engineer



Reviewed By:

Joshua L. Barker, P.E.

JAH/
cc: file, book